

The background of the entire page is a yellow brick wall. The bricks are arranged in a standard staggered pattern. The color is a bright, uniform yellow.

yellobrik[®]

Shape Your Solution

yellobrik Catalog 2024/4
©2024 LYNX Technik AG - Germany
Yellobrik_Catalog_Rev52

yellobrik® | finally, bricks done right...

There are lots of small interface “brick” style products available, and we looked at them all. After carefully studying the pro’s and cons, we started the development of a complete new family of bricks, different and more feature rich than the rest - yellobriks.

We all know how annoying and frustrating it can be when changing a connection or setting parameters when the product manual isn’t readily available. We have adopted a new basic mantra for the development of each new yellobrik device...

“No manual needed”

We clearly identify all connections and signal flow, and everything you need to know is printed right on the module. All controls are easily accessible and clearly labeled, with no need to remove covers, move links or figure out complex dip switch settings.

Even though yellobriks are low cost utility products, reliability and technical performance are key to their functionality. Yellobriks are the most stable and technically proficient bricks available and are backed by excellent after sales service and support.

We include all the accessories needed: The module, universal

AC plug power supply, AC plug adapters plus a USB cable, audio adapters and HDMI cables if required. All of these accessories are included in the price.

We provide free of charge PC or MAC desktop application - yelloGUI and LynxCentraal, which can be used to access extended feature sets and settings within select yellobriks.

Some yellobriks are field upgradeable. The updates are always free of charge. Simply connect your module to the latest yelloGUI or LynxCentraal with a USB cable and click update > yellow in LynxCentraal. Nothing could be easier.

Our innovative 1RU rack mounting chassis lets you move from simple “throw down” solutions to a tidy & organized system installed in a 19” rack frame with central and redundant power protection.

yellobrik modules:*

Modular & Combinable

Rack Mountable

Hot Swappable

*unless stated otherwise

Connections clearly identified

Easy access controls clearly labelled

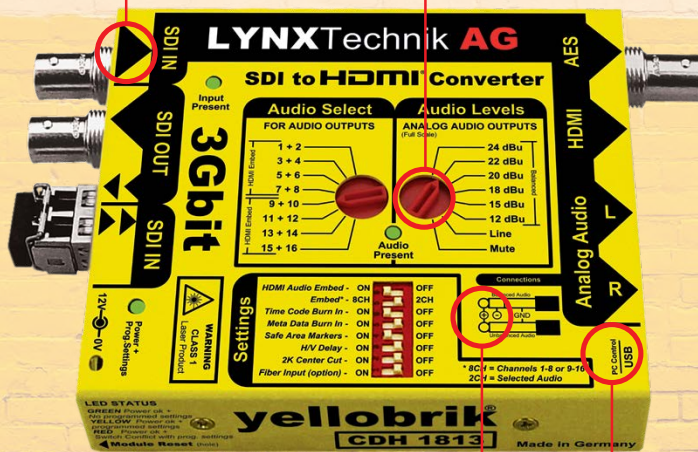

Everything written on the module

USB for updates and PC control**

**on applicable modules



QR codes on the catalog product pages open the product page on the LYNXTechnik website



Introduction

Control Software

LynxCentraal	4
yelloGUI	5

Rack Controllers

SRV 1000	6
yellobrik Server Module	
RCT 1012	7
yellobrik Rack Controller	

Rack Frames

RFR 1200	8
High power yellobrik 19" 1RU Rack Frame	
RXT 1001	8
Power supply holder for RFR 1200	
RFR 1018	9
19"/0.5RU Mounting Tray	
RFR 1001	9
Single yellobrik Mounting Bracket	

Embedder / De-Embedder

PDM 1484 B	10
12G-SDI AES Audio Embedder / De-embedder (unbalanced AES)	
PDM 1484 D	12
12G-SDI AES/Analog Audio Embedder / De-embedder (balanced AES/ Analog)	
PDM 1284 D	14
AES Audio Embedder/Deembedder [Balanced]	

Audio Processing

IDC 1411	16
AI Based Instant Dialogue Cleaner and Amplifier	

Video Converter

PEC 1464	17
H.265 Streamer and Recorder	
CDH 1411	19
12G SDI to HDMI Converter	
CDH 1813	22
3G SDI to HDMI Converter	
CHD 1412	24
CHD 1812-1	26
3G HDMI to SDI Converter + Frame Synchronizer	
CHD 1402	28
4K HDMI to 12 SDI Converter	
CHD 1802-1	29
3G HDMI to SDI Converter	
CQS 1462	30
Bidirectional 2SI/SQD Quad Link ► Single Link Converter	
PMV 1841	32
3G/HD/SD Quad Split Multiviewer	

SDI Frame Sync

PVD 1400	34
12G-SDI Frame Synchronizer	
PVD 1800	36
3G SDI Frame Synchronizer & Up/Down/Cross Converter	

SDI ◄► Fiber Conversion

OTR 1A41	38
8k Fiber Transmission System	

OTR 1A42	40
8k Fiber Transmission System	
OTR 1441	42
4k Fiber Transmission System	
OTR 1442	44
4k Fiber Transmission System	
OTR 1410	46
12G SDI Fiber Optic Transceiver	
OBD 1410	46
12G SDI Bidirectional Fiber Optic Transceiver	
OTR 1810-1	47
3G SDI Fiber Optic Transceiver	
OBD 1810-2	47
3G SDI Bidirectional Fiber Optic Transceiver	
OTR 1440	48
12G SDI Fiber Optic Transceiver [CWDM]	
OTR 1840-1	48
3G SDI Fiber Optic Transceiver [CWDM]	
OTX 1410	49
12G SDI to Fiber Optic Transmitters	
OTT 1412	49
Dual 12G SDI to Fiber Optic Transmitters	

SDI ► Fiber Conversion

OTX 1440	50
12G SDI to Fiber Optic Transmitters [CWDM]	
OTT 1442	50
Dual 12G SDI to Fiber Optic Transmitters [CWDM]	
OTX 1812	51
3G SDI to Fiber Optic Transmitters	
OTT 1812-1	51
Dual 3G SDI to Fiber Optic Transmitters	
OTX 1842	52
3G SDI to Fiber Optic Transmitters [CWDM]	
OTT 1842-1	52
Dual 3G SDI to Fiber Optic Transmitters [CWDM]	
ORX 1400	53
12G Fiber Optic to Dual SDI Receiver	
ORR 1402	53
Dual 12G Fiber Optic to Dual SDI Receiver	
ORX 1802-2	54
3G Fiber Optic to Dual SDI Receiver [CWDM]	
ORR 1802-2	54
Dual 3G Fiber Optic to Dual SDI Receiver [CWDM]	
OTX 1712-2	55
Analog Sync/Video Fiber Optic Transmitter	
OTX 1742-2	55
Analog Sync/Video Fiber Optic Transmitter [CWDM]	

Analog Sync ► Fiber Conversion

ORX 1702-1	56
Analog Sync/Video Fiber Optic Receiver	
OET 1910	57
10Gbit/s Ethernet/Fiber Optic Transceiver	
OBD 1910	57
10Gbit/s Ethernet/Bidirectional Fiber Optic Transceiver	

Ethernet ◄► Fiber Converter

OET 1940 (MS/MC)	58
10Gbit/s Ethernet to Fiber Transceiver	

OET 1514.....	59	1Gbit/s Ethernet/Fiber Optic Transceiver	LC/ST DUP	76	Duplex LC/PC to ST/PC Adapter
OET 1510.....	59	1Gbit/s Ethernet/Fiber Optic Transceiver	LC/FC DUP	76	Duplex LC/PC to FC/PC Adapter
OET 1544	60	1Gbit/s Ethernet/Fiber Optic Transceiver - Switch [CWDM]	LC/LC DUP	76	Duplex LC/PC Patch Cable
OET 1540	60	1Gbit/s Ethernet/Fiber Optic Transceiver - Switch [CWDM]	LC/SC SIM	76	Simplex LC/PC to SC/PC Adapter
OBD 1514 E.....	61	1Gbit/s Ethernet/Bidirectional Fiber Optic Transceiver	LC/ST SIM	76	Simplex LC/PC to ST/PC Adapter
OBD 1510 E.....	61	1Gbit/s Ethernet/Bidirectional Fiber Optic Transceiver	LC/FC SIM	76	Simplex LC/PC to FC/PC Adapter
Serial ◀▶ Fiber Converter			LC/LC SIM	76	Simplex LC/PC Patch Cable
ODT 1510	62	Serial and GPI Fiber Transceiver	Power Supplies		
OBD 1510 D.....	63	RS232/422/485 Serial and GPI Bidirectional Fiber Transceiver	RPS 1001.....	77	12V/15W AC to DC Power Supply for Single yellobrik
ODT 1540	64	Serial and GPI Fiber Transceiver [CWDM]	RPS A100	78	12V/100W AC to DC Desktop Power Supply
OTR 1210	65	MADI Fiber Transceiver	P-TAP 1000	78	
OBD 1210.....	65	MADI Bidirectional Fiber Transceiver	XLR 1000	78	
MADI ◀▶ Fiber Converter			Contact & Service		
OTR 1240	66	MADI/Fiber Transceiver [CWDM]	Knowledge Base.....	79	
DVD 1417	67	12G 1▶7 SDI Reclocking Distribution Amplifier	Get in Touch	79	
DVD 1423	67	12G Dual 1▶3 SDI Reclocking Distribution Amplifier	Video Distribution		
Video Distribution			DVD 1817	68	3G 1▶7 SDI Reclocking Distribution Amplifier
DVD 1817	68	3G 1▶7 SDI Reclocking Distribution Amplifier	DVD 1823	68	3G Dual 1▶3 SDI Reclocking Distribution Amplifier
DVD 1823	68	3G Dual 1▶3 SDI Reclocking Distribution Amplifier	DVA 1714	69	Wide Band 1▶4 Analog Video/Sync Distribution Amplifier
DVA 1714	69	Wide Band 1▶4 Analog Video/Sync Distribution Amplifier	Sync Pulse Generator		
Sync Pulse Generator			SPG 1708	70	Tri-/Bi-Level Sync Pulse Generator with Genlock
SPG 1708	70	Tri-/Bi-Level Sync Pulse Generator with Genlock	OSW 1022.....	71	2x2 Optical Switch
OSW 1022.....	71	2x2 Optical Switch	Optical Switch		
Optical Switch			Optical Multiplexers / Splitters		
Optical Multiplexers / Splitters			OCM 1891	72	9 Channel CWDM Mux/Demux [1270nm-1430nm]
OCM 1891	72	9 Channel CWDM Mux/Demux [1270nm-1430nm]	OCM 1892.....	73	9 Channel CWDM Mux/Demux [1450nm-1610nm]
OCM 1892.....	73	9 Channel CWDM Mux/Demux [1450nm-1610nm]	OCM 1841, OCM 1842, OCM 1843, OCM 1844	74	4 Channel CWDM Mux/Demux
OCM 1841, OCM 1842, OCM 1843, OCM 1844	74	4 Channel CWDM Mux/Demux	OSP 1812, OSP 1812M, OSP 1814.....	75	Passive Optical Splitters
OSP 1812, OSP 1812M, OSP 1814.....	75	Passive Optical Splitters	Optical Accessories		
Optical Accessories			LC/SC DUP.....	76	Duplex LC/PC to SC/PC Adapter
LC/SC DUP.....	76	Duplex LC/PC to SC/PC Adapter			

General Information

LynxCentraal is a complimentary control software tool. It allows users to access their LYNX Technik products remotely (including yellobrik modules) and gain extended features via a PC or MAC.

The software will scan the USB ports to detect directly connected modules. These can also be connected via a powered USB Hub. If an RCT 1012 is connected, it will also display modules that are connected to the RCT. If you have several RCT structures (more than three) a SRV 1000 apollo server module is necessary to connect to these sections.

By clicking on "yellow" available modules can be selected from a list, displaying a graphical layout for connections and I/O. Depending on the module extended settings can also be applied, previews seen or outputs routed.

Override Physical Settings

Some modules will have a "settings" button, which allows the user to override the local switch settings and change them using the GUI controls. The LED on the yellobrik will turn RED indicating that at least one of the local switch settings has been overwritten by the software.

Note: As soon as any local switch is changed, the settings revert back to the physical switch settings.

Signal Flow View

The signal flow screen (selected using the button at the bottom of the GUI) offers a useful graphical representation of the video and/or audio signal flow through the module. Relevant controls are also placed in the signal paths so you can see exactly what signal the setting is changing. The signal path only illuminates when signals are present.

Firmware Up/Downgrading

By selecting Update > Yellow you can update your connected yellobriks. It is necessary to either install the Local Database or have a registered Lynx database account and internet connection. To log in and connect to the lynx database click Update > Database settings and fill out your credentials in the "Registration" section.

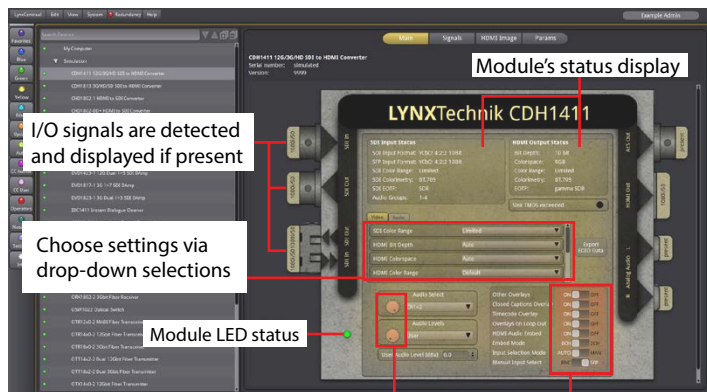

Controls marked in red indicate physical switches on the module. Status is indicated initially. Changes will prompt a warning.

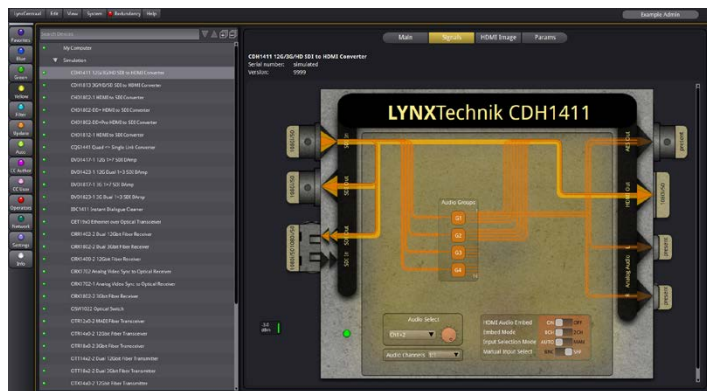
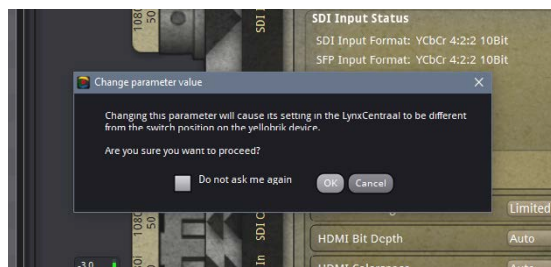

Where can I find LynxCentraal?

LynxCentraal is and will always be free.
Download it today for your MAC or PC via



LynxCentraal.lynx-technik.com

General Information

yelloGUI is a complimentary software application. It allows users to access the yellobrik module controls and extended features via a PC or MAC.

The software will scan the USB ports to detect the connected module. When a module is connected, the appropriate user interface is automatically displayed. The display is a graphical representation of the module's layout for connections and I/O. The yelloGUI software application is designed to be intuitive and easy to use. Theoretically a USB hub or a 'daisy chain' will allow up to 127 yellobrik to be connected to a single PC or Mac. (A powered USB hub may be required)

Signal Flow View

The signal flow screen (selected using the button at the bottom of the GUI) offers a useful graphical representation of the video and/or audio signal flow through the module. Relevant controls are also placed in the signal paths so you can see exactly what signal the setting is changing. The signal path only illuminates when signals are present.

Click on the model number to bring up additional selections.

The additional selections are used to undo or redo settings, import and export stored settings, and perform a factory reset.

The "about" option is useful to determine the module's firmware version.

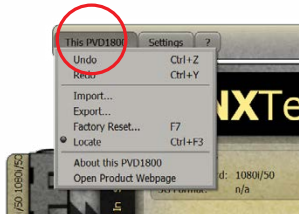

Access to additional information and screen displays are provided using the buttons along the bottom of the GUI

Controls marked in red indicate physical switches on the module. Status is indicated but cannot be changed via the software, unless enabled under settings.

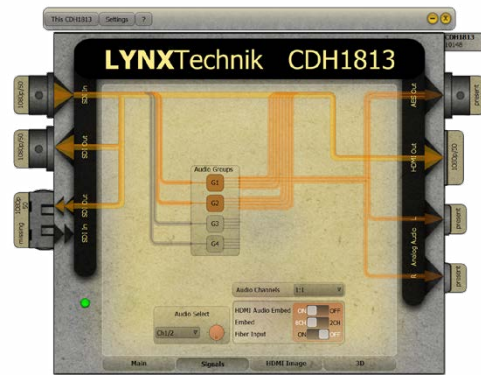

Override Physical Settings

Some modules will have a "settings" button, which allows the user to override the local switch settings and change them using the GUI controls. The LED on the yellobrik will turn RED indicating that at least one of the local switch settings has been overwritten by the software.

Note: As soon as any local switch is changed, the settings revert back to the physical switch settings.

Additional Help Understanding Parameters

The GUI offers contextual help for many of the module's functions. For enhanced help, click on the "question mark" and select "what's this". A small question mark will now appear on the mouse cursor. Simply click on the parameter you wish to know more about and more details will be provided.

Get Connected

Register for a direct connection to our update server and yelloGUI will automatically let you know when a new release of the firmware is available for download. Simply click and install the firmware update directly from the application. The new "simulate mode" will let you explore the GUI controls for all supported modules.

Where can I download yelloGUI?

yelloGUI is and will always be free. Download it today for your MAC or PC via

yellogui.lynx-technik.com

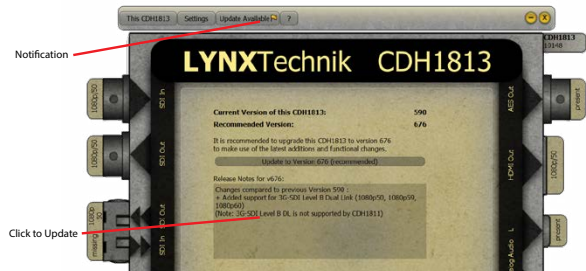

Notification

Click to Update

SRV 1000

yellobrik Server Module

LYNX | Centraal.
compatible



Video

Audio

Data

Optical

Racks

Optional

Features

- System building block for use with LynxCentraal
- Supports up to 256 LYNX Rack Controllers
- Enables AutoControl and CustomControl in LynxCentraal
- Facilitates system wide backups of device settings and restore at will
- Copy & Paste settings between same model modules
- SNMPv2 and Lynx Remote Control Interface Protocol support for third party control software
- 1 x RJ 45 10/100 Ethernet connection

Description

The SRV 1000 is a yellobrik control module, designed to simplify the control of complex yellobrik systems. Unlock powerful features with LynxCentraal, like automation, backup and restore, customized control panels, centralized updates, and more.

Automate your setup with AutoControl. The graphical "if...then" configurator makes event handling easy without programming knowledge. This can be set up for any compatible yellobrik and Series 5000 card. React to almost anything, from PSU failures to video signal status changes.

With CustomControl you can create panels for your monitoring and control needs. Show data like temperature, fan speed, and more. Choose buttons, switches, and dials with individual functions. A single panel can be used to interface one or multiple products. Accessibility to panels can be limited to LynxCentraal users.

Use the "Backup and Restore" function to make snapshots of settings for entire systems, single devices, or anything in between. Restore them with the click of a button anytime.

Full SNMPv2 support and the Lynx Remote Control Interface Protocol enable third-party control software to also work with SRV 1000 and all connected devices.

Technical Specifications

Network	10/100 Ethernet - RJ-45 Connector
Power	+12V DC @ 1.5W nominal - (supports 7 - 24V DC input range)
Physical	Size: 108 mm x 90mm x 22mm (4.25" x 3.54" x 0.86") Weight: 145g (5.1oz)
Ambient	5 - 40°C (41 - 104°F) 90% Humidity (non condensing)
Model #	SRV 1000- (EAN# 4250479429031)
Includes	Module, AC power supply

Application Example: Basic Setup

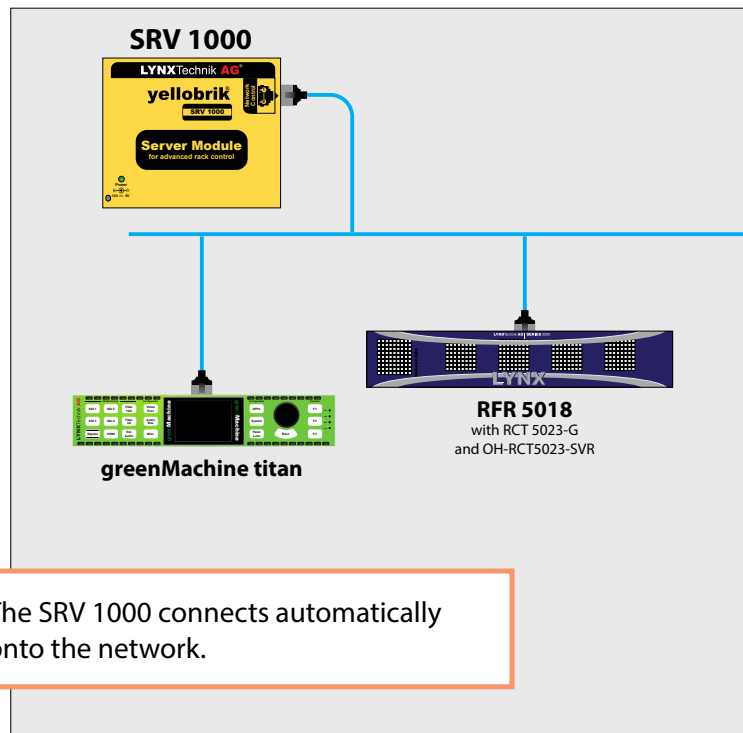

RCT 1012

yellobrik Rack Controller

LYNX | Centraal.
compatible



Features

- One slot yellobrik module
- Supports control up to 12 yellobriks
- Provides 12 USB A ports for connection
- 4 x GPI connections for monitoring power supply status of RFR 1200
- 1 x RJ 45 10/100/1000 Ethernet connection
- 1 x Reset button for changing the settings to default values
- 1 x mini USB for maintenance
- LED Status for power, USB overcurrent, and high temperature warning
- SRV 1000 compatible to access module settings

Description

The RCT 1012 is a compact one slot yellobrik module designed to combine the control of up to 12 yellobrik modules to an ethernet port. It is a one-stop installed solution for the management and control of several yellobriks in an easy, fast, and efficient manner without requiring an individual connection to each module for setting parameters or updating the firmware. All connected yellobrik modules are visible on the network remotely.

RCT 1012 automatically discovers the connected yellobrik modules and displays them in the device tree below the controller node. It allows bulk firmware updates of all the selected yellobrik modules and facilitates the configuration of all the connected yellobriks via the IP network.

RCT 1012, when mounted on an RFR 1200 rack frame, will provide status information of the primary and redundant power supply via 4 GPI contacts.

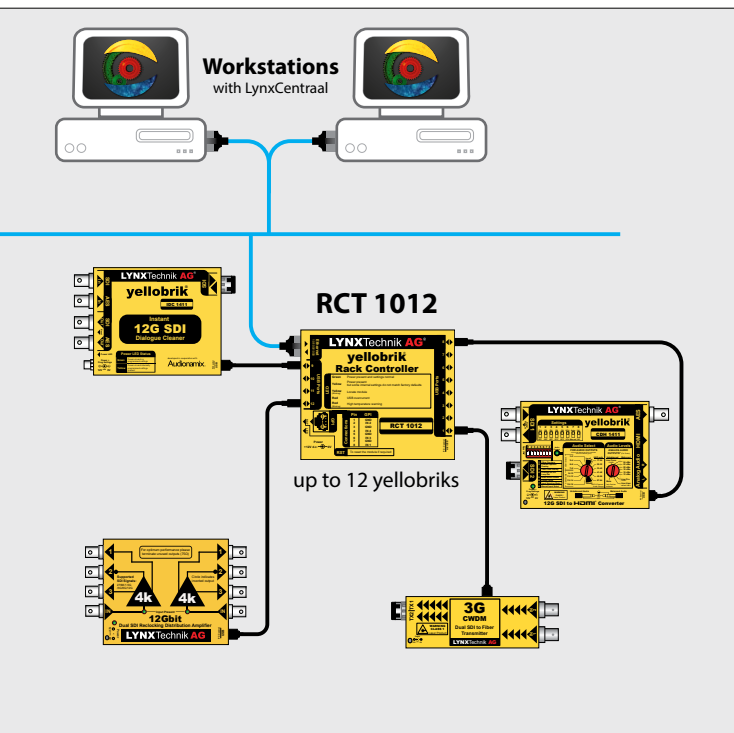

Technical Specifications

Network	10/100/1000 Ethernet - RJ-45 Connector
USB	12x USB Type A 1 x mini USB type B
GPI	Connector: RJ45 with 4x External GPI inputs GPI 1 to 4: used for monitoring RFR 1000 primary and redundant power supplies
Power	+12V DC @ 2.3W nominal - (supports 7 - 24V DC input range)
Physical	Size: 108 mm x 90mm x 22mm (4.25" x 3.54" x 0.86") Weight: 185g (6.5oz)
Ambient	5 - 40°C (41 - 104°F) 90% Humidity (non condensing)
Model #	RCT 1012- (EAN# 4250479326675)
Includes	Module, AC power supply

RFR 1200

High power yellobrik 19" 1RU Rack Frame



Features

- Compact 1 RU design
- Will accommodate up to 14 yellobriks
- External 12VDC power inputs
- Primary and redundant power options
- Power failure alarm GPI outputs
- Adjustable 19" mounting brackets to recess frame

Description

The RFR 1200 is a compact 1 RU high mounting frame designed for yellobriks. Up to 14 yellobriks can be mounted vertically and mechanically clamped in place. Each slot has its own integrated power connector on a central power bus which can supply up to 200W of power total.

The rack has two external 12VDC inputs for power. If the total of all connected devices stays below 100W, "Power 1" will be for primary power, "Power 2" for redundant backup. In high power mode both power supplies are used in parallel to supply a total of 200W power budget to the rack. To indicate status LEDs are located in the front panel as well as GPI connections for the power supply failure alarms.

While the frame will accommodate all yellobriks (except OCM, OSP, OTR 1441, OTR 1442, OTR 1A41 and OTR 1A42), it is especially well suited for yellobrik fiber converters, which are typically used in larger numbers.

A space is left open on one side to route the fiber loops from front to rear making for a very clean installation. The module fiber RX and TX activity LEDs can be seen from the front with the modules installed. To protect the fiber cables and connections the 19" mounting brackets can be repositioned to recess the rack frame.

To mount wider modules (i.e. IDC 1411) the spacer brackets can be unscrewed from the bottom to make room to accommodate these types of modules.

Technical Specifications

Power Inputs	External +12VDC primary power input External +12VDC redundant power input Connector: Molex Mini Fit Series557 Power LEDs on front of chassis Primary and redundant power failure GPO alarm outputs
Size	19" Rack mount x 1RU high x 145mm deep (5.7")
Weight	1.6 kg (3.52 Lbs) - with no modules or power supplies installed
Model #	RFR 1200 (EAN# 4250479329041)
Optional Accessoires	RPS A100 AC to DC Desktop Power Supply Module 12V/8A (N/EU/US/UK) (with None / EU / US / UK plug respectively) <small>(use 2 units for redundant 100W application or non-redundant 200W application)</small> RXT 1001 Power Supply Holder for Rack Power Supplies
Includes	Rack Frame assembly (empty) and qty 14 module securing brackets

Application Example



Side view of a fully equipped RFR 1200, including the optional power supplies for primary and redundant power supply.

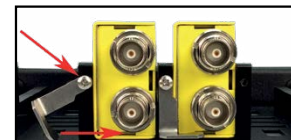
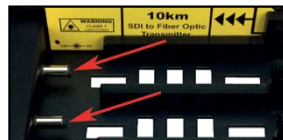

Modules are clamped securely into position by their power supply connector (left) and the rack clamps (top).

RXT 1001

Power supply holder for RFR 1200

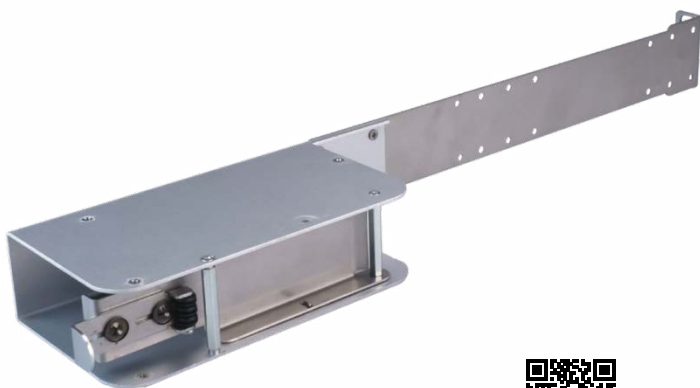

Features

- Compact design
- Accommodates 1 power supply
- Innovative locking system to secure power supply
- Easy installation
- Compatible with RPS 1120, RPS 6120, and RPS A100 power supplies

Description

External power supplies have been a struggle for everyone seeking a clean organized installation and setup. RXT 1001, a power supply holder for RFR 1200 yellobrik rack frame, can simplify cable management by securing the external power supply and making the installation neat.

Technical Specifications

Size (max.)	447mm x 103.35mm x 44mm (17.6in x 4.07in x 1.73in)
Weight	380g (13.4oz)
Model #	RXT 1001 (EAN# 4250479327962)
Includes	1x power supply holder, 1x mounting bracket, 4 screws

RFR 1018**19"/0.5RU Mounting Tray****Features**

- Small footprint only 0.5 RU High x 19" Rack mount
- For use with:
 - » OCM 1891 / 1892
 - » OCM 1841 / 1842 / 1843 / 1844
 - » OSP 1812 / 1812M / 1814
 - » OTX 1441 / ORX 1441
 - » OTX 1442 / ORX 1442
 - » OTX 1A41 / ORX 1A41
 - » OTX 1A42 / ORX 1A42
- Easy module mounting - no tools needed
- Combine with RFR 1200 frame for system use

Description

The RFR 1018 Mounting Tray is designed to accommodate a variety of LYNX yellobrik modules providing a secure mounting platform in any standard 19" rack.

Modules are easily installed from the front and held securely in place a thumbscrew.

When combined with the RFR 1200 Chassis (which can accommodate up to 14 fiber yellobriks) a fully featured 18 channel modular CWDM system can be accommodated in a total of 1.5RU rack space - see below.

Technical Specifications

Size	L 400mm (19") x D 135mm (5.3") x H 0.5RU
Material	Aluminum
Weight	0.4kg (0.9Lbs)
Model #	RFR 1018 - (EAN# 4250479310186)
Includes	Mounting Chassis

Application Example**RFR 1001****Single yellobrik Mounting Bracket****Features**

- Robust metal mounting bracket
- Mount on any flat surface
- Ideal for mounting on 19" rack rails
- No tools needed for module installation

Description

The RFR 1001 is a robust metal mounting solution for a single yellobrik. The bracket can accommodate the smaller and larger modules using the mounting slots provided in the yellobrik.

The bracket can be mounted on any flat surface using suitable screws or bolts (not supplied). The mounting holes are on 19" rack rail centers which makes it ideal for mounting yellobriks in the rear of equipment rack frames; keeping them secure and out of the way.

No tools are required for module installation and removal, this is accomplished using a nylon thumbscrew.

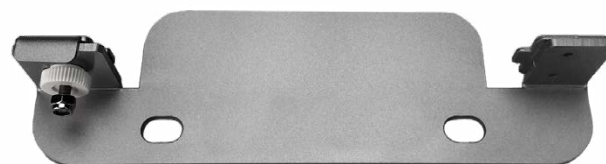
**Technical Specifications**

Size	L 400mm (19") x D 135mm (5.3") x H 0.5RU
Material	Aluminum
Weight	0.4kg (0.9Lbs)
Model #	RFR 1018 - (EAN# 4250479310186)
Includes	Mounting Chassis

PDM 1484 B

12G-SDI AES Audio Embedder / De-embedder (unbalanced AES)

compatible with

LYNX | Centraal

yelloGUI

Video

Audio

Data

Optical

Racks

Optional



Shown with optional Fiber SFP Installed

Visit the product page:



Features

- Multifunction - use as an embedder or de-embedder
- Ideal as bidirectional master
- 3G-SDI Level A and Level B support
- SDI video formats up to 12Gbit (2160p60)
- 4 x AES inputs or outputs with selectable audio groups
- Fiber I/O option for long distance transmission
- Integrated 1 kHz test tone generator
- Automatic PCM / encoded audio detection
- Auto black if no video present
- Selectable SDTV 24 bit mode
- Video and Audio present LED indicators
- LynxCentraal & yelloGUI compatible for additional internal settings

Description

The PDM 1484 B is a versatile AES audio embedder and de-embedder designed for a wide range of SDI video formats up to 12G-SDI. It supports unbalanced AES3id audio I/O using 75 Ohm BNC connections.

Audio groups are selected using the rotary switches, and its possible to embed and de-embed additional audio groups by cascading modules together. Simultaneous embedding and de-embedding means the module will de-embed and output the audio from the selected audio group before overwriting with new audio (if required). The module automatically detects audio formats and will deactivate the sample rate converters to preserve encoded bit streams such as DolbyE.

The "auto black" mode uses a black video frame if no SDI input is present. This allows the module to embed audio even when no video source is available. This mode is useful if the module is being used in an "audio only" application. A 1 kHz test tone generator is included for audio testing purposes.

The module is also compatible with LynxCentraal and yelloGUI software package, which provide access to a host of additional internal settings which include manual insertion of metadata (AFD,WSS,VI).

An SDI fiber input and output is also provided with a variety of plug in SFP options available.

Technical Specifications

SDI Input	1 x SDI video on 75 Ohm BNC connector				
	SMPTE 259M, SMPTE 292M, SMPTE 424M, SMPTE 2081-1, SMPTE 2082-1				
	Multi-standard operation from 270Mbit/s to 12Gbit/s				
	SDTV (525/625)				
	720p (23.98/24/25/29.97/30/50/59.94/60 Hz)				
	1080psf (23.98/24/25/29.97/30 Hz)				
	1080i (50/59.94/60 Hz)				
	1080p (23.98/24/25/29.97/30/50/59.94/60 Hz)				
	2160p (23.98/24/25/29.97/30/50/59.94/60 Hz)				
	Electrical Return Loss:	to 1.5GHz >15dB	to 3GHz >10dB	to 6GHz >7dB	to 12GHz >4dB
Automatic Cable EQ**	270Mbit/s	1.5Gbit/s	3Gbit/s	6Gbit/s	12Gbit/s
	340m	200m	150m	100m	100m
	Belden 1694A			Belden 4794R	
SDI Output	1 x SDI video on 75 Ohm BNC connector				
	SMPTE 259M, SMPTE 292M, SMPTE 424M, SMPTE 2081-1, SMPTE 2082-1				
	Electrical Return Loss:	to 1.5GHz: >15dB	to 3GHz >10dB	to 6GHz >7dB	to 12GHz >4dB
Fiber I/O	(optional) 1 x fiber optic input and output (see table)				
	SMPTE 297M - 2006				
AES I/O (switchable)	4 x AES3id unbalanced inputs or outputs on 75 Ohm BNC connectors				
	AES group selection provided via rotary switch				
Power	+12VDC @ 10.87W nominal - (supports 8 - 14VDC input range)				
Physical	Size (incl. connectors): 140mm x 90mm x 22mm (5.51" x 3.54" x 0.86")				
	Weight (excl. SFP): 195g (6.88oz)				
Ambient	5 - 40°C (41 - 104°F) 90% Humidity (non condensing)				
Model #	PDM 1484 B - (EAN# 4250479329058)				
Includes	Module, AC power supply				



CAUTION: This is a high power module. If mounting the module in the RFR 1200 rack frame please leave an empty slot each side of the module to allow for adequate airflow to prevent the risk of overheating.

*Distance is an approximation. Actual distances achieved can be longer or shorter depending on the type of cable. Determine link losses and perform optical budget calculations to ensure correct operation.

Application Example: Unbalanced AES Audio Transport

The basic SDI embedding and de-embedding applications for the PDM 1484 B are somewhat obvious, but with the “auto-black” mode the modules can be used to transport audio signals only. This provides a very cost-effective way to transport multichannel audio over fiber without the need for external optical multiplexing. The example below shows how two modules in each location can be used to transport 16 x digital audio signals between two locations over fiber.

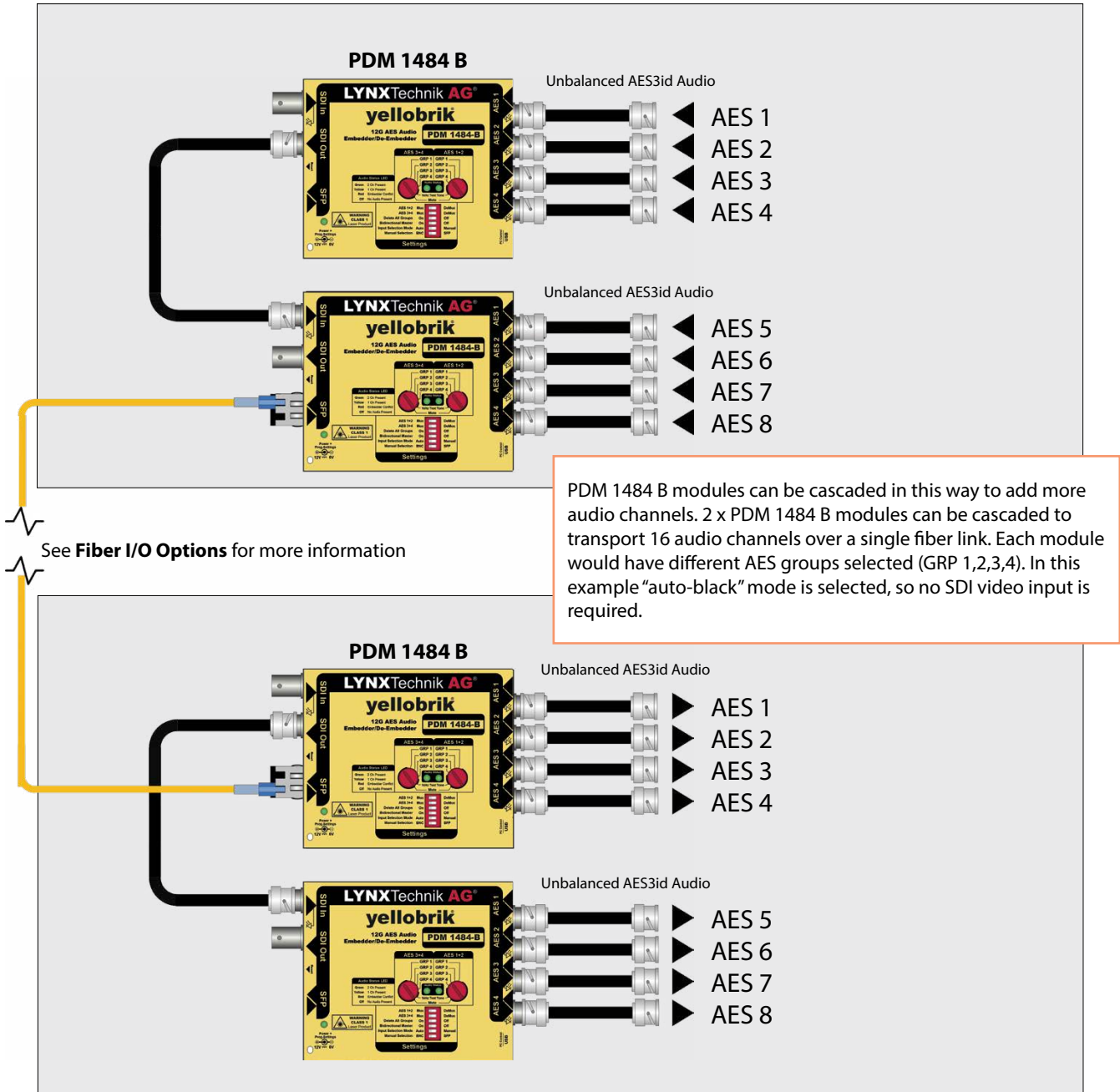

- Video
- Audio
- Data
- Optical
- Racks
- Optional

*Distance is an approximation. Actual distances achieved can be longer or shorter depending on the type of cable. Determine link losses and perform optical budget calculations to ensure correct operation.

PDM 1484 D

12G-SDI AES/Analog Audio Embedder / De-embedder (balanced AES/ Analog)

compatible with

LYNX | Centraal

yelloGUI

Video

Audio

Data

Optical

Racks

Optional



Shown with optional Fiber SFP Installed

Visit the product page:



Features

- Simultaneous embedding and de-embedding
- Ideal as bidirectional master
- 3G-SDI Level A and Level B support
- SDI video formats up to 12G-SDI (2160p60)
- 4 x AES/Analog inputs / outputs with selectable audio groups
- Optional Fiber I/O
- Integrated 1 kHz test tone generator
- Automatic PCM / encoded audio detection
- Auto black if no video present
- Selectable SDTV 24 bit mode
- Video and Audio present LED indicators
- LynxCentraal & yelloGUI compatible for additional internal setting

Description

The PDM 1484 D is a versatile AES audio embedder and de-embedder designed for a wide range of SDI video formats up to 12G. It supports balanced AES and analog audio I/O using a 25 pin SubD connector. The 25 pin SubD breakout board RBO A025 is included.

Audio groups are selected using the rotary switches or control software. It is possible to embed and de-embed additional audio groups by cascading modules together. Simultaneous embedding and de-embedding means the module will de-embed and output the audio from the selected audio group before overwriting with new audio (if required).

The module automatically detects audio formats and will deactivate the sample rate converters to preserve encoded bit streams such as DolbyE. A 1 kHz test tone generator is included for audio testing purposes.

Analog audio processing for embedding can be set to balanced and unbalanced input modes. Balanced I/O can be 24, 22, 20, 18, 15, 12 dBu, professional line level or user defineable fullscale level.

The "auto black" mode uses a black video frame if no SDI input is present. This allows the module to embed audio even when no video source is available. This mode is useful if the module is being used in an "audio only" application.

The module is also compatible with the LynxCentraal and yelloGUI control software, which provides access to a host of additional internal settings.

Technical Specifications

SDI I/O	1 x SDI video input on BNC connector (75 Ohm)
	1 x SDI video output on BNC connector (75 Ohm)
	SMPT E 259M, SMPT E 292M, SMPT E 424M, SMPT E 2081-1, SMPT E 2082-1
	Multi-standard operation from 270Mbit/s to 12Gbit/s
	SDTV (525/625)
	720p (23.98/24/25/29.97/30/50/59.94/60 Hz)
	1080psf (23.98/24/25/29.97/30 Hz)
	1080i (50/59.94/60 Hz)
	1080p (23.98/24/25/29.97/30/50/59.94/60 Hz)
	2160p (23.98/24/25/29.97/30/50/59.94/60 Hz)
	Electrical Return Loss: to 1.5GHz >15dB to 3GHz >10dB to 6GHz >7dB to 12GHz >4dB
	270Mbit/s 1.5Gbit/s 3Gbit/s 6Gbit/s 12Gbit/s
	Automatic Cable EQ* 340m 200m 150m 100m 100m
	Belden 1694A Belden 4794R
Fiber I/O	(optional) 1 x fiber optic input and output (see table)
	SMPT E 297M - 2006
AES I/O	4 x AES3 balanced inputs on 25 pin SubD Connector (110 Ohm)
	4 x AES3 balanced outputs on 25 pin SubD Connector (110 Ohm)
	AES group selection provided via rotary switch
Analog Audio I/O	4 x Analog audio input on 25 pin SubD Connector (10k Ohm)
	4 x Analog audio output on 25 pin SubD Connector (150 Ohm)
	Balanced I/O mode for 24, 22, 20, 18, 15, 12 dBu, professional line level and user defineable full scale level (selectable)
Power	+12VDC @ 12.96W nominal - (supports 8 - 14VDC input range)
Physical	Size (incl. connectors): 126mm x 90mm x 22mm (4.96" x 3.54" x 0.86")
	Weight (excl. SFP): 200g (7.05oz)
Ambient	5 - 40°C (41 - 104°F) 90% Humidity (non condensing)
Model #	PDM 1484 D - (EAN# 4250479329065)
Includes	Module, RBO A025, AC power supply



CAUTION: This is a high power module. If mounting the module in the RFR 1200 rack frame please leave an empty slot each side of the module to allow for adequate airflow to prevent the risk of overheating.

*Distance is an approximation. Actual distances achieved can be longer or shorter depending on the type of cable. Determine link losses and perform optical budget calculations to ensure correct operation.

Application Example: Balanced AES/Analog Audio Transport

The basic SDI embedding and de-embedding applications for the PDM 1484 D are somewhat obvious, but with the "auto-black" mode the modules can be used to transport audio signals only. This provides a very cost-effective way to transport multichannel audio over fiber without the need for external optical multiplexing. The example below shows how two modules in each location can be used to transport 16 x digital audio signals between two locations over fiber.

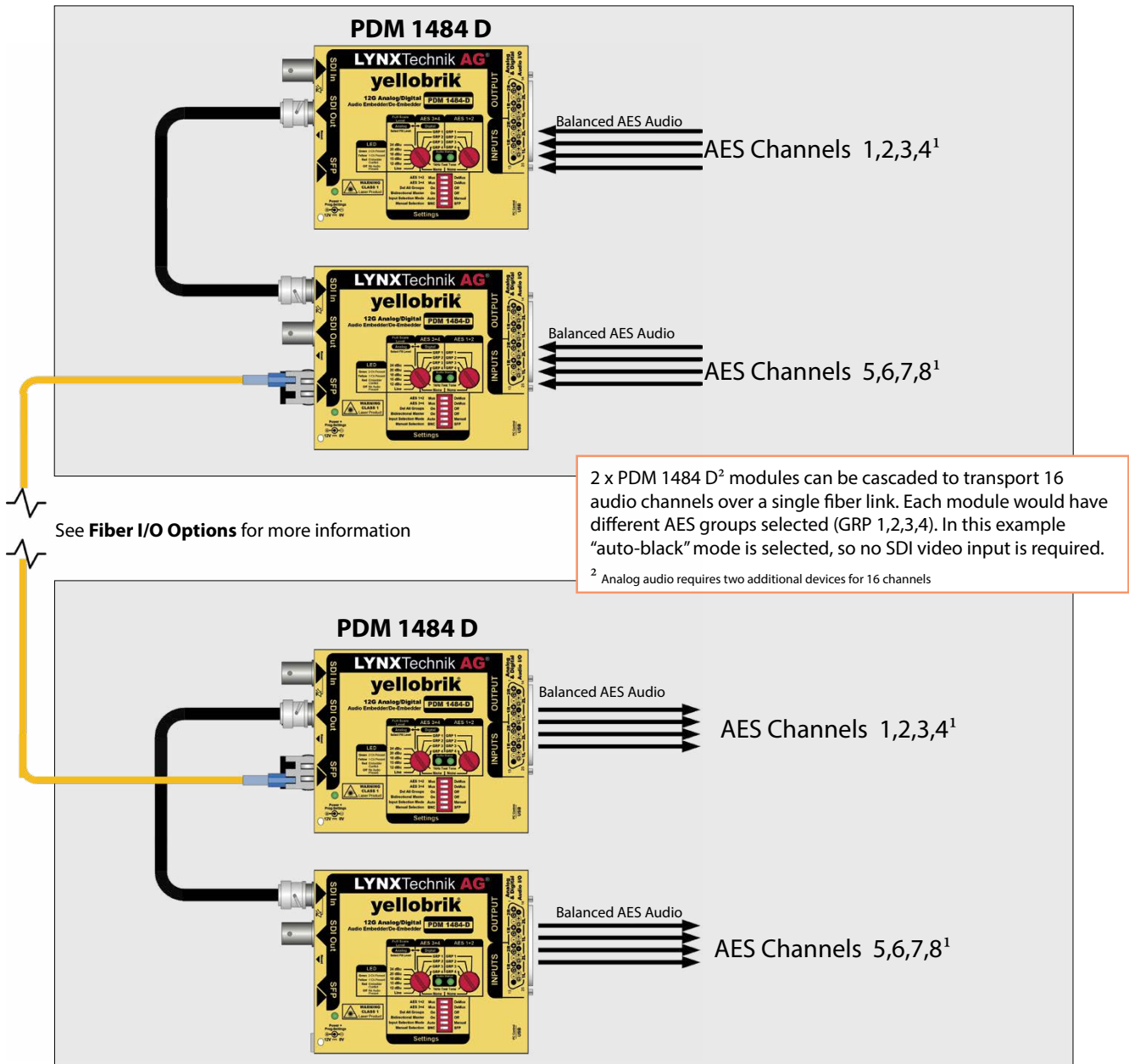

¹ In-/Outputs can also be Analog Audio of different input level per device.

Fiber I/O Options:

This yellobrik **DOES NOT INCLUDE** any fiber SFP modules. If you wish to order certified and tested LYNX Technik SFP modules, please specify the required SFP when ordering. The Fiber SFP I/O Options list is a set of examples for SFP modules to use with the module.

SFPs with a lower SDI data rate (i.e. OH-TX-1-LC , the 3G alternative of the OH-TX-12G-LC) usually work with the chosen yellobrik.

SDI Fiber Transmitter Options			
Model	Description	Power	
OH-TX-12G-LC	12G SFP Fiber TX - Singlemode - LC conn. - 10km	-5 ... +0.5dBm	
SDI Fiber Receiver Options			
Model	Description	Sensitivity	
OH-RX-12G-LC	12G SFP Fiber RX - Singlemode - LC Connector	-10dBm (12G)/ -14dBm (6G/3G)/ -16dBm (1.5G)	
SDI Fiber Transceiver Options			
Model	Description	Power	Sense
OH-TR-12G-LC	SFP Fiber RX/TX - Singlemode - LC Conn. - 10km	-5 ... 0.5 dBm	-10dBm (13G/6G)/ -14dBm (3G/1.5G)
OH-TR-12G-XXXX-LC	12G CWDM SFP Fiber RX/TX - SM - LC Conn. - 10km	-2 ... +3 dBm	-10dBm (13G/6G)/ -14dBm (3G/1.5G)

*Distance is an approximation. Actual distances achieved can be longer or shorter depending on the type of cable. Determine link losses and perform optical budget calculations to ensure correct operation.

PDM 1284 D

AES Audio Embedder/Deembedder [Balanced]

compatible with

LYNX | Centraal

yelloGUI

Video

Audio

Data

Optical

Racks

Optional

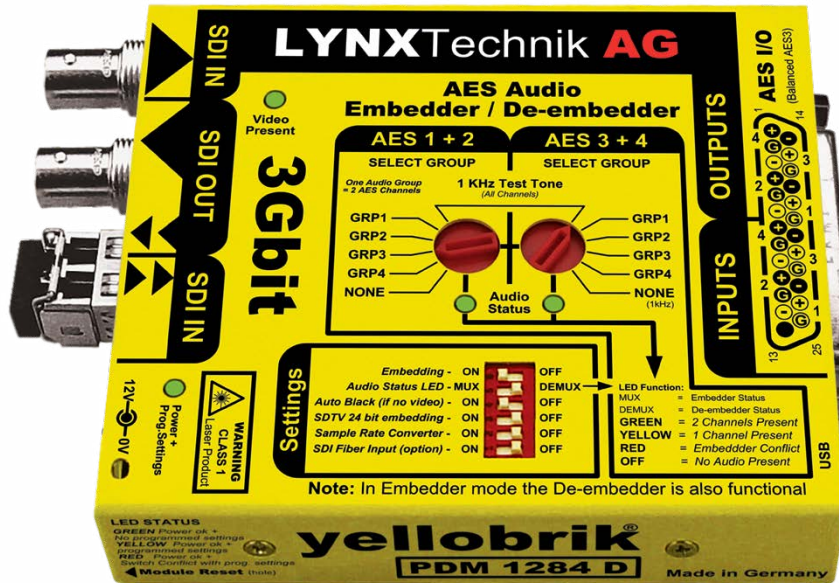

Shown with optional Fiber SFP Installed

Visit the product page:



Features

- Simultaneous embedding and de-embedding
- 3G SDI Level A and Level B support
- SDI video formats up to 3Gbit (1080p60)
- 4 x AES inputs / outputs with selectable audio groups
- Optional Fiber I/O
- Integrated 1 kHz test tone generator
- Automatic PCM / encoded audio detection
- Auto black if no video present
- Selectable SDTV 24 bit mode
- Video and Audio present LED indicators
- Internal full mono audio shuffling via yelloGUI and LynxCentraal

Description

The PDM 1284 D is a versatile AES audio embedder and de-embedder designed for a wide range of SDI video formats up to 3Gbit. It supports balanced AES3 audio I/O using a 25 pin SubD connector.

Audio groups are selected using the rotary switches, and its possible to embed and de-embed additional audio groups by cascading modules together. Simultaneous embedding and de-embedding means the module will de-embed and output the audio from the selected audio group before overwriting with new audio (if required). The module automatically detects audio formats and will deactivate the sample rate converters to preserve encoded bit streams such as DolbyE.

The "auto black" mode uses a black video frame if no SDI input is present. This allows the module to embed audio even when no video source is available. This mode is useful if the module is being used in an "audio only" application.

The module is also compatible with yelloGUI and LynxCentraal, providing access to a wide range of additional internal settings which includes manual insertion of metadata (AFD,WSS,VI).

A 1 kHz test tone generator is included for audio testing purposes.

Technical Specifications

SDI Input	1 x SDI video on 75 Ohm BNC connector SMPTE 424M, SMPTE 292M, SMPTE 259M 3G Level A & B-DL & B-DS according to SMPTE ST 425-1 and ST 425-2 (3D) with image formats 1280 x 720 and 1920 x 1080 Multi-standard operation from 270Mbit/s to 3Gbit/s SDTV (525/625) 720p and 1080p (23.98/24/25/29.97/30/50/59.94/60 Hz) 1080psf (23.98/24/25/29.97/30 Hz) 1080i (50/59.94/60 Hz) Electrical Return Loss: >15dB from 5MHz to 1.5GHz, >10dB from 1.5GHz to 3GHz Automatic Cable EQ* (Belden 1694A cable) 340m @ 270Mbit/s, 150m @ 1.5Gbit/s, 120m @ 3Gbit/s
Fiber I/O	(optional) 1 x fiber optic input and output (see table) SMPTE 297M - 2006
SDI Output	1 x SDI video on 75 Ohm BNC connector SMPTE 424M, SMPTE 292M, SMPTE 259M Electrical Return Loss: >15dB from 5MHz to 1.5GHz, >10dB from 1.5GHz to 3GHz
AES Inputs	4 x AES3 balanced inputs on 25 pin SubD Connector (110 Ohm) AES group selection provided via rotary switch
AES Outputs	4 x AES3 balanced outputs on 25 pin SubD Connector (110 Ohm) AES group selection provided via rotary switch
Power	+12V DC @ 4.2W nominal - (supports 8 - 14V DC input range)
Physical	Size (incl. connectors): 128mm x 90mm x 22mm (5.04" x 3.54" x 0.86") Weight: 200g (7.05oz)
Ambient	5 - 40°C (41 - 104°F) 90% Humidity (non condensing)
Model #	PDM 1284 D - (EAN# 4250479312852)
Includes	Module, AC power supply, SubD adapter PCB, mini USB cable

*Distance is an approximation. Actual distances achieved can be longer or shorter depending on the type of cable. Determine link losses and perform optical budget calculations to ensure correct operation.

Application Example: Balanced AES Audio Transport

Balanced AES Audio

The basic SDI embedding and de-embedding applications for the PDM 1284 D are somewhat obvious, but with the “auto-black” mode the modules can be used to transport audio signals only. This provides a very cost-effective way to transport multichannel audio over fiber without the need for external optical multiplexing. The example below shows how two modules in each location can be used to transport 16 x digital audio signals between two locations over fiber.

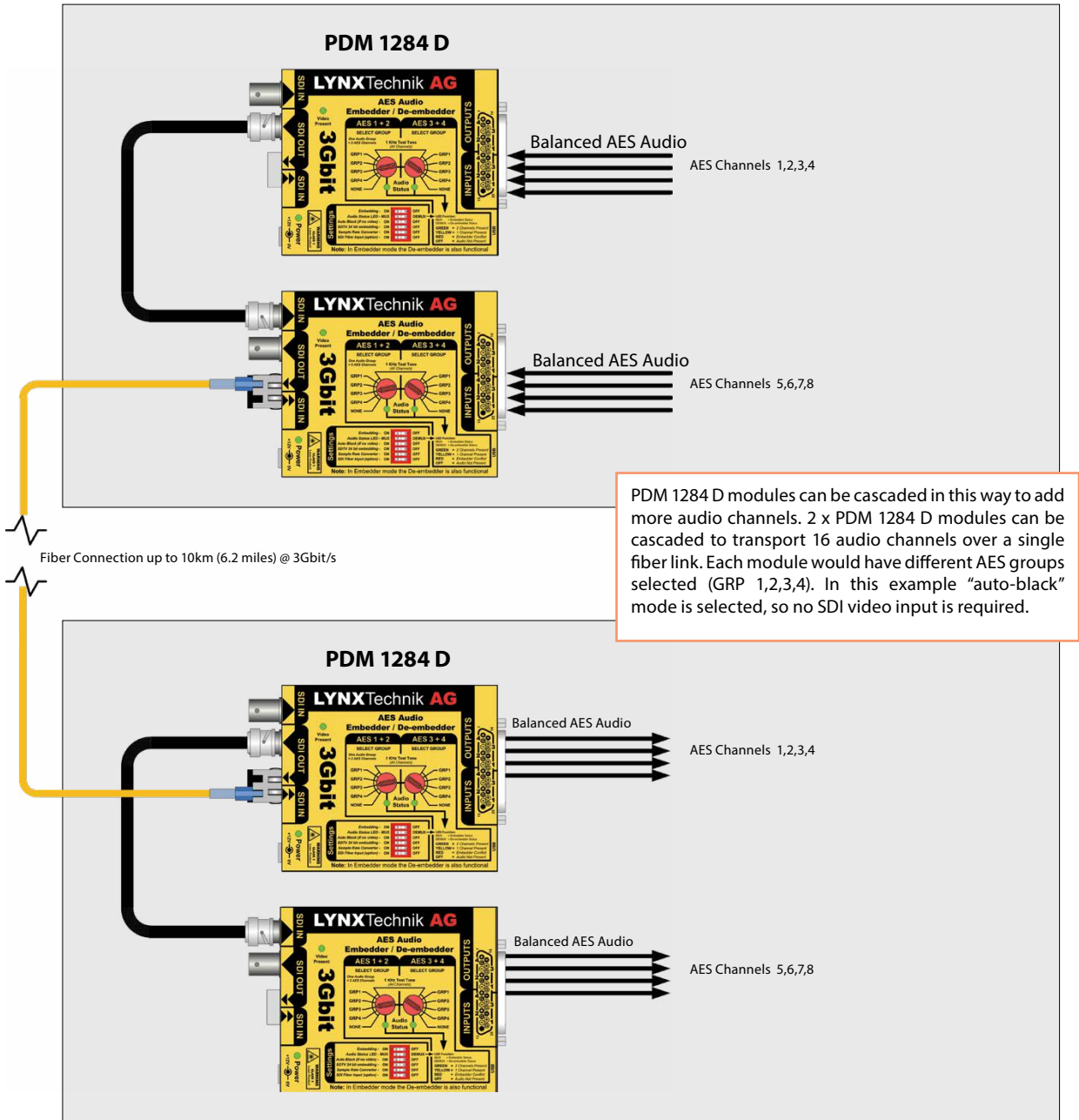

*Distance is an approximation. Actual distances achieved can be longer or shorter depending on the type of cable. Determine link losses and perform optical budget calculations to ensure correct operation.

compatible with

LYNX | Centraal

yelloGUI

Video

Audio

Data

Optical

Racks

Optional



Shown with optional Fiber SFP Installed

Visit the product page:



Features

- Support for 1.5G, 3G and 12G/4K SDI video Input
- Support for AES Input
- Support for optional 3G/12G fiber SFP
- Automatic Video Delay in tandem with Audio Delay
- Settings for Speech Gain, Background Gain, Compressor and more.
- Settings and routing can be applied via control software
- Remote Control via LynxCentraal or yelloGUI

Description

The IDC 1411 is the hardware solution for enhancing speech based on the Audionamix® Instant Dialogue Cleaner Software Plugin. Application examples include parallel production of content for hearing impaired viewers or improved production of automated closed captions with clearer audio.

It is designed to process uncompressed SDI video formats via BNC or fiber, and AES based audio via BNC. SDI Output can be routed to fiber or BNC via the Lynx Centraal control software.

When connected to a control terminal via LynxCentraal or yelloGUI the IDC 1411 has additional audio filtering: The IDC setting itself, two sequential equalizers, and a compressor. Additionally each filter section has its own gain settings.

The module is suitable for all SMPTE standard signals conforming to SMPTE 292M, 424M, and 2082 (1.5Gbit/s, 3Gbit/s, and 12Gbit/s)

SFP Module Options

Model	Description	Power	Sense
SDI Fiber Transceiver Options			
OH-TR-12G-LC	SFP Fiber RX/TX - Singlemode, LC Connector - 10km	-5dBm	-10dBm
OH-TR-12G-XXXX-LC	CWDM SFP Fiber RX/TX - Singlemode LC Conn. - 10km* XXXX=Wavelength	-2dBm	-10dBm
SDI Fiber Transmitter Options			
OH-TX-12G-LC/ST	SFP Fiber TX - Singlemode, LC or ST Connector - 10km	-5dBm	-
OH-TR-12G-XXXX-LC/ST	CWDM SFP Fiber TX - Singlemode LC or ST Conn. - 10km* - 18 Wavelengths according to ITU T G692.2 [1270nm - 1610nm]	-2dBm	-
SDI Fiber Receiver Options			
OH-RX-12G-LC/ST	SFP Fiber RX - Singlemode, LC or ST Connector	-	-10dBm

CAUTION: This is a high power module. If mounting the module in the RFR 1200 rack frame please leave an empty slot each side of the module to allow for adequate airflow to prevent the risk of overheating.

Technical Specifications

SDI Video	1 x SDI input on 75 Ohm BNC connectors 1 x SDI output on 75 Ohm BNC connectors SMPTE ST 2082, SMPTE 424M, SMPTE 292M Multi-standard operation from 1.5Gbit/s to 12Gbit/s Multirate reclocking: 1.5Gbit/s - 3Gbit/s - 12Gbit/s			
Automatic Cable EQ*	1.5Gbit/s	3Gbit/s	12Gbit/s	
	220m*	140m*	80m*	
	Belden 1694A		Belden 4794R	
Fiber Optic	1 x fiber optic input, 1 x fiber optic output Duplex (singlemode) using LC/PC connection SMPTE ST297-1:2015, ST297-2:2017			
Transmitter	Wavelength	See Optional SFP Table		
	Optical power	See Optional SFP Table		
Receiver	Sensitivity	See Optional SFP Table		
Max. distance*	See Optional SFP Table			
AES Input	AES3-id on 75 Ohm BNC, 2 channels			
AES Output	AES3-id on 75 Ohm BNC, 2 channels			
Power	+12V DC @ 13W nominal - (supports 10 - 24V DC input range)			
Physical	Size (incl. connectors)	138mm x 90mm x 44mm (5.43" x 3.54" x 1.72")		
	Weight:	360g (12.7oz)		
Ambient	5 - 40°C (41 - 104°F) 90% Humidity (non condensing)			
Model #	IDC 1411	4250479328914		
Includes	Module, AC power supply			

Processing Delay

The timing of the SDI and AES Output will be locked to the SDI Input. Additional delay introduced by the audio processing will be compensated depending on the video refresh-rate resulting in the following input to output delay:

Video Standard	720p		1080i	1080psF	1080p		2160p	
Refresh Rate	30,	50	59,	50, 59,	25, 29,	23,	50	59,
	29,		60	60	30	24,	50	60
	25,					25,		
	24,					30		
	23							
Delay (in frames)	2	3	4	2	2	2	3	4

*Distance is an approximation. Actual distances achieved can be longer or shorter depending on the type of cable. Determine link losses and perform optical budget calculations to ensure correct operation.

PEC 1464

H.265 Streamer and Recorder

compatible with

LYNX | Centraal™

yelloGUI

Visit the
product page:

Features

- HDMI and 12G-SDI UHD video input
- Analog Audio Input
- H.264 and H.265 encoding
- Supported streaming formats
 - » RTMP & RTMPS
 - » RTP/RTSP
 - » TS over UDP or RTP
 - » HLS (HTTP Live)
 - » SRT Listener/Caller/Rendezvous
 - » Unicast or Multicast
- Record to USB 3.0
- Realtime Logo Insertion
- Custom Image and Test Pattern Transmission fallback
- Advanced Text Overlays
- Mobile friendly Web UI for configuration
- IP network Status and Configuration via LynxCentraal over USB

Description

The PEC 1464 is a versatile, compact H.264/H.265 streamer and recorder designed for a wide range of applications in the broadcast, film and pro AV industry. The module can take a 12G-SDI or HDMI source then stream and record it simultaneously.

Two channels of audio are de-embedded from the video input. In addition, the PEC 1464 has a line audio input and either one of these audio sources can be used for the streamer and/or recorder.

Support for real time logo insertion and advanced text overlays on the video signal with control over size and text position. A custom image or color bars can be displayed when the video input is lost or missing (transmission fallback).

The PEC 1464 supports a wide range of streaming standards as well as unicast and multicast operations. A mobile friendly Web UI allows for a simple configuration from a PC, Mac, tablet or smartphone.

The PEC 1464 is compatible with LynxCentraal for remote configuration and status monitoring. This is particularly useful when managing several Lynx Technik devices.

Note: For legal reasons, HDMI capture devices from LYNX Technik AG are designed not to capture, convert or transmit video or audio from HDCP copy-protected sources (e.g. Satellite receivers, Cable receivers, etc.)

SFP Module Options Other modules available on request

SDI Fiber Receiver Options		Sensitivity
OH-RX-12G-LC	12G-SDI Single Channel Optical Receiver - LC Connector	-16dBm (1.5G) -14dBm (3G - 6G) -10dBm (12G)

Technical Specifications

Video Inputs	1 x 75 Ohm BNC SDI input; 1 x HDMI 2.0b, Type A connector																														
Video Formats	<table border="1"> <thead> <tr> <th></th> <th>12G-SDI (SMPTE 2082)</th> <th>3840 x 2160p</th> <th>50 / 59.94 / 60</th> </tr> </thead> <tbody> <tr> <td rowspan="3">SDI</td> <td>6G-SDI (SMPTE 2081)</td> <td>3840 x 2160p</td> <td>25 / 29.97 / 30</td> </tr> <tr> <td>3G-SDI (SMPTE 424M)</td> <td>1920 x 1080p</td> <td>50 / 59.94 / 60</td> </tr> <tr> <td rowspan="2">1.5G-SDI (SMPTE 292M)</td> <td>1920 x 1080p</td> <td>25 / 29.97 / 30</td> </tr> <tr> <td>1920 x 1080i</td> <td>50 / 59.94 / 60</td> </tr> <tr> <td rowspan="3">HDMI</td> <td rowspan="2">UHD</td> <td>1280 x 720p</td> <td>50 / 59.94 / 60</td> </tr> <tr> <td>3840 x 2160p</td> <td>25 / 29.97 / 30 / 50 / 59.94 / 60</td> </tr> <tr> <td rowspan="2">HD</td> <td>1920 x 1080p</td> <td>25 / 29.94 / 30 / 50 / 59.94 / 60</td> </tr> <tr> <td>1920 x 1080i</td> <td>50 / 59.94 / 60</td> </tr> <tr> <td></td> <td>1280 x 720p</td> <td>50 / 59.94 / 60</td> </tr> </tbody> </table>		12G-SDI (SMPTE 2082)	3840 x 2160p	50 / 59.94 / 60	SDI	6G-SDI (SMPTE 2081)	3840 x 2160p	25 / 29.97 / 30	3G-SDI (SMPTE 424M)	1920 x 1080p	50 / 59.94 / 60	1.5G-SDI (SMPTE 292M)	1920 x 1080p	25 / 29.97 / 30	1920 x 1080i	50 / 59.94 / 60	HDMI	UHD	1280 x 720p	50 / 59.94 / 60	3840 x 2160p	25 / 29.97 / 30 / 50 / 59.94 / 60	HD	1920 x 1080p	25 / 29.94 / 30 / 50 / 59.94 / 60	1920 x 1080i	50 / 59.94 / 60		1280 x 720p	50 / 59.94 / 60
	12G-SDI (SMPTE 2082)	3840 x 2160p	50 / 59.94 / 60																												
SDI	6G-SDI (SMPTE 2081)	3840 x 2160p	25 / 29.97 / 30																												
	3G-SDI (SMPTE 424M)	1920 x 1080p	50 / 59.94 / 60																												
	1.5G-SDI (SMPTE 292M)	1920 x 1080p	25 / 29.97 / 30																												
1920 x 1080i		50 / 59.94 / 60																													
HDMI	UHD	1280 x 720p	50 / 59.94 / 60																												
		3840 x 2160p	25 / 29.97 / 30 / 50 / 59.94 / 60																												
	HD	1920 x 1080p	25 / 29.94 / 30 / 50 / 59.94 / 60																												
1920 x 1080i		50 / 59.94 / 60																													
	1280 x 720p	50 / 59.94 / 60																													
Color Precision	YCbCr 4:2:2 10-bit																														
Video Encoder	H.265 according to MPEG-H Part 2 (HEVC): <ul style="list-style-type: none"> • Main, Main 10, Main 4:2:2 H.264 according to MPEG-4 Part 10 (AVC): <ul style="list-style-type: none"> • Baseline, Main, High, High 10, High 4:2:2 																														
Video Processing	<ul style="list-style-type: none"> • Downscaling • Frame Rate Down Conversion • Text Overlay • Logo Inserter (JPEG RGB, PNG24, PNG8, TIFF, static GIF, BMP) • Transmission Fallback Option: Test Pattern or Custom Image (png, jpeg) 																														
Audio I/O	<ul style="list-style-type: none"> • Input: 8 Channel embedded SDI Audio Input • Unbalanced analog line audio input - 3.5mm stereo jack • Output: Streaming Protocol dependant: <ul style="list-style-type: none"> - RTMP, RTMPS: 1 Stereo Channel - TS-UDP, TS-RTP, HLS, SRT, RTSP: 4 Stereo Channels 																														
Audio Processing	<ul style="list-style-type: none"> • Processing Options: Channel Mapping, Gain, Mute, Sample Rate, Bitrate • Audio Loss Reply Fallback Option: Mute, Testtone 																														
Protocols	<ul style="list-style-type: none"> • TS over UDP, RTP • RTP/RTSP • RTMP/RTMPS • HLS • SRT Listener, Caller, and Rendezvous 																														
Recording	1x USB 3.0 Female Type "A" Connector (Supported formatting: FAT32, exFAT, vFAT, Ext2, Ext3, Ext4) Output Container: .mp4, .ts, .mov (Max. recoding time for .mov and .mp4: 4 hours)																														
Network	10/100/1000 Ethernet (RJ-45)																														
Power	+12V DC @ 16W (supports 10 to 24V DC input range)																														
Physical	Size: 124mm x 90mm x 50mm (4.88" x 3.54" x 1.9685") incl. connectors Weight: 230g (8.11oz)																														
Ambient	0 - 45 °C (32 - 113 °F) 90% Humidity (non condensing)																														
Model #	PEC 1464 - (EAN# 4250479329492)																														
Includes	Module, AC power supply, mini USB cable, ethernet cable																														



CAUTION: This is a high power module. If mounting the module in the RFR 1200 rack frame please leave an empty slot each side of the module to allow for adequate airflow to prevent the risk of overheating.

*Distance is an approximation. Actual distances achieved can be longer or shorter depending on the type of cable. Determine link losses and perform optical budget calculations to ensure correct operation.

Application Example

Streaming and Archiving in 12G-SDI & 4K UHD

The PEC 1464 can stream and record footage simultaneously to an external hard drive. Writing to an external hard drive requires at least USB 2.0 for 3G footage. Writing 4K footage to a hard drive is only possible with USB 3.0.

Switchover if SDI and/or HDMI input drops is also possible.

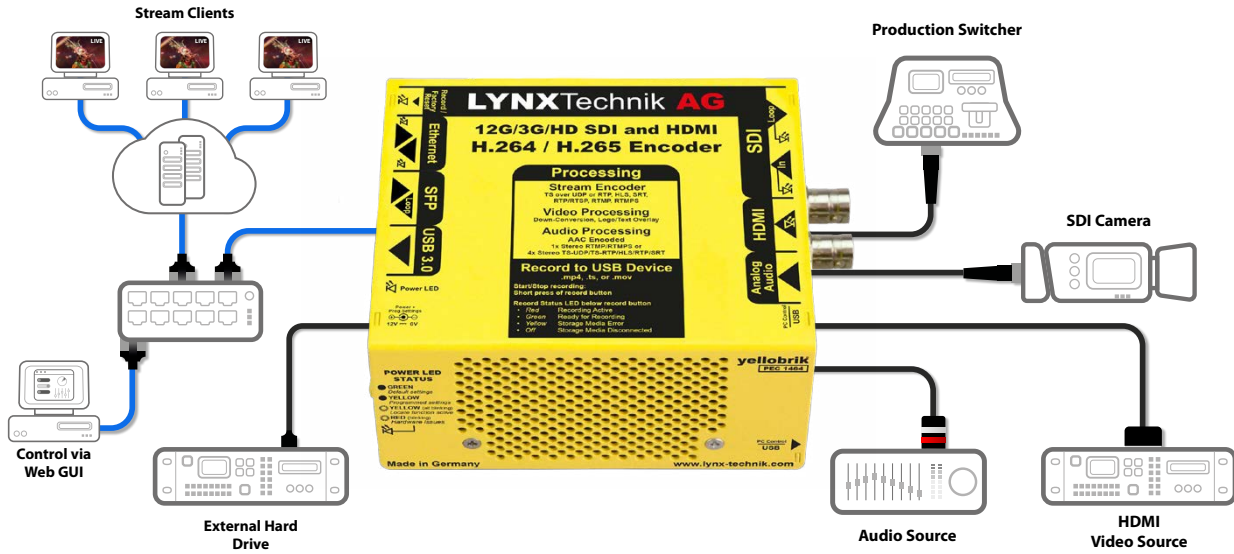

Stream live to a Content Delivery Network (CDN) and make a backup recording at the same time



Multicast a video feed into a network

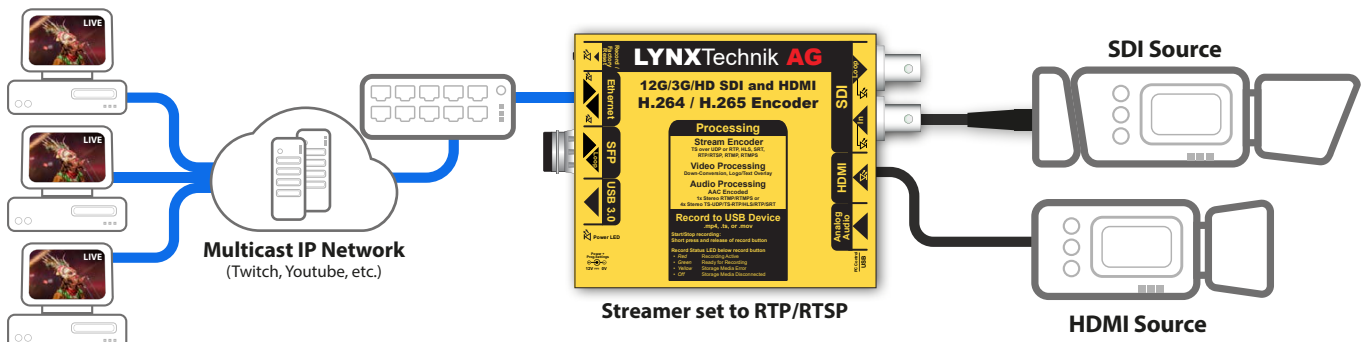

*Distance is an approximation. Actual distances achieved can be longer or shorter depending on the type of cable. Determine link losses and perform optical budget calculations to ensure correct operation.

CDH 1411**12G SDI to HDMI Converter**

compatible with

LYNX | Centraal™**yelloGUI**Visit the
product page:**Features**

- Support for SDI video inputs up to 12Gbit/s (2160p)
- Supports HDR and WCG indication at HDMI output
- Automated detection of input signal color range via VPID information
- 3G SDI Level A and Level B support
- Automatic input standard and format detection
- Fiber input and output options
- HDMI video output with embedded audio
- Analog and AES audio outputs
- Selectable timecode burn-in and Metadata burn-in
- CEA 708 Closed caption burn-in
- 16 channel on screen audio level meter
- H/V delay & flip and safe area markers
- yelloGUI and LynxCentraal compatible: Gain access to additional features

Description

The CDH 1411 is a versatile, compact 12G SDI to HDMI converter designed to combat a host of monitoring and display applications in broadcast, post production and pro AV markets. Convert any SDI video signal into an HDMI signal for monitoring and display. Fiber connectivity options add SDI fiber transmission and/or SDI fiber reception using the integrated fiber SFP socket.

Two channels of audio can be de-embedded providing digital AES and analog audio outputs. Analog audio outputs have selectable full scale range presets. The two selected audio channels can also be embedded into the HDMI output. Alternatively 8 channels selected from the input signal (8 audio groups in 64 channels) can be embedded into the HDMI output.

Various burn in features make the CDH 1411 a true monitoring tool. Individually selectable timecode burn-in, Closed Caption burn-in, 16 channel audio metering, safe area markers and Metadata display are just a few of the on-screen monitoring features. Lynx Centraal and yelloGUI provide support for a wide range of additional settings and features which are accessed using a PC and the USB port on the module.

SFP Module Options

Model	Description	Power	Sense
SDI Fiber Transceiver Options			
OH-TR-12G-LC	SFP Fiber RX/TX - Singlemode, LC Connector - 10km	-5dBm	-10dBm
SDI CWDM Fiber Transceiver Options			
OH-TR-12G-XXXX-LC XXXX=Wavelength	CWDM SFP Fiber RX/TX - Singlemode LC Conn. - 10km* 18 wavelengths according to ITU T G692.2 (1270nm-1610nm)	-2.. +3dBm	-10dBm

Technical Specifications

SDI Video	1 x SDI input on 75 Ohm BNC connectors 1 x SDI output on 75 Ohm BNC connectors SMPTE 2082, SMPTE ST 2081, SMPTE 424M, SMPTE 292 3G Level A & B-DL & B-DS according to SMPTE ST 425-1 Multi-standard operation from 1.5Gbit/s to 12Gbit/s Multirate relocking: 1.5Gbit/s - 3Gbit/s - 6Gbit/s - 12Gbit/s		
	Automatic Cable EQ**	1.5Gbit/s 190m	3Gbit/s 150m
		Belden 1694A	Belden 4794R
Fiber Optic	1 x fiber optic input, 1 x fiber optic output Duplex (singlemode) using LC/PC connection SMPTE 297M - 2006		
	Transmitter	Wavelength	See Optional SFP Table
		Optical power	See Optional SFP Table
	Receiver	Sensitivity	See Optional SFP Table
	Max. distance*	See Optional SFP Table	
HDMI Output	10bit HDMI 2.0b support including deep color and embedded audio Type A connector 24bit (3x8bit) and 30bit (3x10bit) deep color (R,G,B / Y,Cr,Cb / X,Y,Z) 2 or 8 channel audio embedding (selectable)		
AES Output	AES3-id on 75 Ohm BNC, 2 channels (selectable)		
Audio Output	Left and right analog audio using 3.5mm jack sockets Balanced mode with 24, 22, 20, 18, 15, 12dBu, Line Level Pro (4dBu) and Line User Unbalanced mode with Line Level Cons (-10 dBV)		
Power	+12V DC @ 3.7W nominal - (supports 10 - 24V DC input range)		
Physical	Size	140m x 90mm x 22mm (incl. connectors) (5.51" x 3.54" x 0.86")	
	Weight:	230g (8.11oz)	
Ambient	5 - 40°C (41 - 104°F) 90% Humidity (non condensing)		
Model #	CDH 1411	4250479327436	
Includes	Module, AC power supply, HDMI + mini USB cable		



CAUTION: This is a high power module. If mounting the module in the RFR 1200 rack frame please leave an empty slot each side of the module to allow for adequate airflow to prevent the risk of overheating.

*Distance is an approximation. Actual distances achieved can be longer or shorter depending on the type of cable. Determine link losses and perform optical budget calculations to ensure correct operation.

Monitoring Features

The CHD 1411 provides a clean 1:1 HDMI conversion of the SDI input signal. There are also a number of other HDMI monitoring options available. These monitoring modes are activated using the module dip switch and can be used individually or as combined monitoring modes.

Clean Feed



- Direct conversion of SDI input
- HDMI output is the same as the SDI input resolution and frame rate (CDH 1411 does not scale)
- Colorspace, Colometry, Color Range, and Bit-Depth for HDMI output can be set via yelloGUI or LynxCentraal
- Manual EOTF settings available.

Burn in Windows

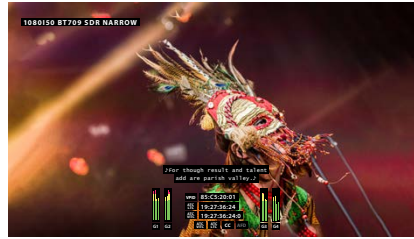

- Display two timecode values if present: VITC and LTC
- SDI input format/frame rate
- Up to 16 audio level meters
- Closed Caption and VI meta-data presence markers
- VITC, LTC, CC and AFD present indicators
- Display Closed Captions

Safe Area Markers

- Default: SMPTE Safe Action (default can be changed using yelloGUI or LynxCentraal)
- Center cross marker
- Curtain Transparency (30-100%)
- Safe From Aspect Ratio Markers
- Choose from eight Colors



H / V Delay & H Flip

- View horizontal and vertical blanking
- Horizontal flipping (if required)

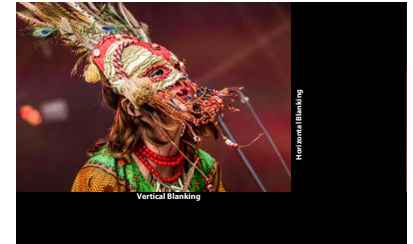

Parameters

The CHD 1411 features full yelloGUI and LynxCentraal support that provides access to additional features and settings not possible from the module's local controls. Additional settings include:

Safe Area Parameter	Settings
Safe Area Markers	OFF
	SMPTE Safe Action (90/90)
	SMPTE Safe Title (80/80)
	EBU Action (3.5/3.5)
	EBU Graphics (5/10)
Aspect Ratio Markers	OFF
	4:3
	16:9
Curtain Transparency	100%
	Adjustable 30%-90%
Center Cross	OFF
	ON
Marker Color	White
	Red, Green, Blue, Yellow, Cyan, Magenta, Black
Safe Area from Aspect	OFF
	ON

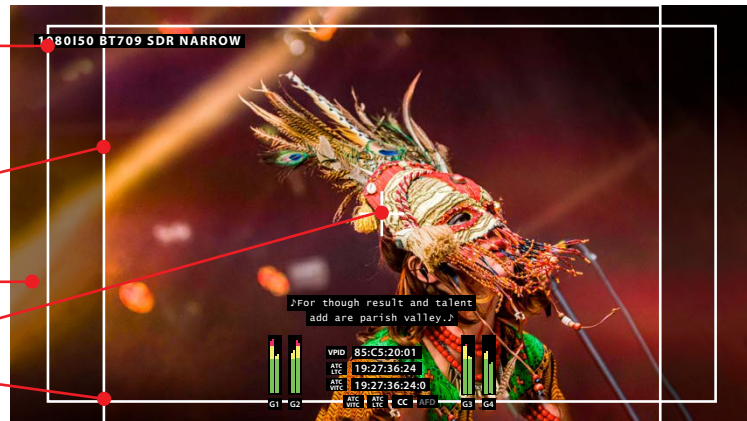

The on screen markers can be custom configured to suit any application. This includes various "standard" safe area markers, aspect ratio markers with adjustable curtain transparency. The color of the markers may also be changed.

Video Parameter	Settings	Video Parameter	Settings	Audio Parameter	Settings
SDI Color Range	AUTO	HDMI Bit Depth	Auto	3G Level B Audio Source	Stream A
	SMPTE Limited		8 bit		Stream B
	Full Range		10 bit	Audio Channels	1:1
HDMI Color Range	Default		12 bit		Convert*
	SMPTE Limited	HDMI EOTF	Auto		
	Full Range		gamma SDR		
HDMI Colorimetry	Auto		gamma HDR		
	BT.709		ST.2084 PQ		
	BT.2020		HLG		
HDMI Colorspace	Auto	Flip Output Signal	No Flip		
	RGB		H (Horizontal)		
	YCbCr 4:2:2				
	YCbCr 4:4:4				

= Default Settings

*DEFAULT: Audio channels 1 through 8 are mapped 1:1 from SDI to HDMI. When set to "Convert" channels 3 and 4 are swapped resulting in channel allocations per SMPTE 320M (3=center /4=LFE) and CEA-861 (3=LFE / 4=FrontCenter)

*Distance is an approximation. Actual distances achieved can be longer or shorter depending on the type of cable. Determine link losses and perform optical budget calculations to ensure correct operation.

Application Example

Fiber Application Using CDH 1411 SDI to HDMI Converter

Sample application using two CDH 1813 modules for SDI fiber optic transmission up to 10km (6.2 miles) @3Gbit/s with integrated HDMI signal confidence monitoring at each end.

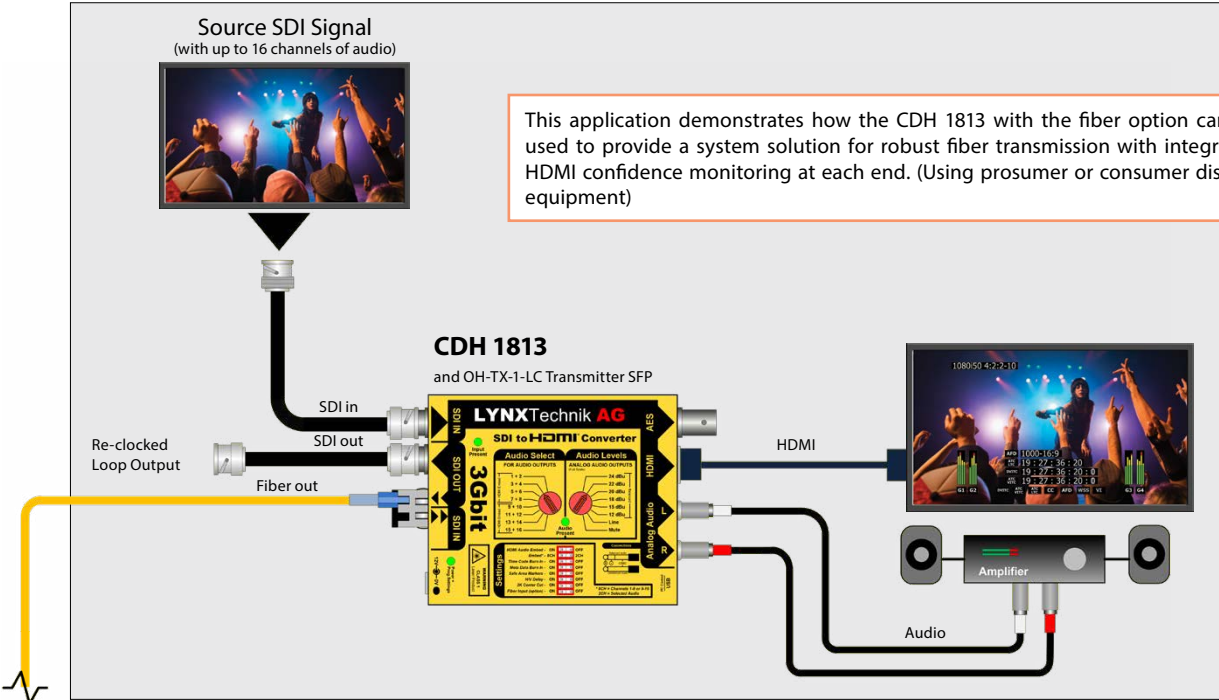

Fiber connection up to 10km (6.2 miles) @ 3Gbit/s

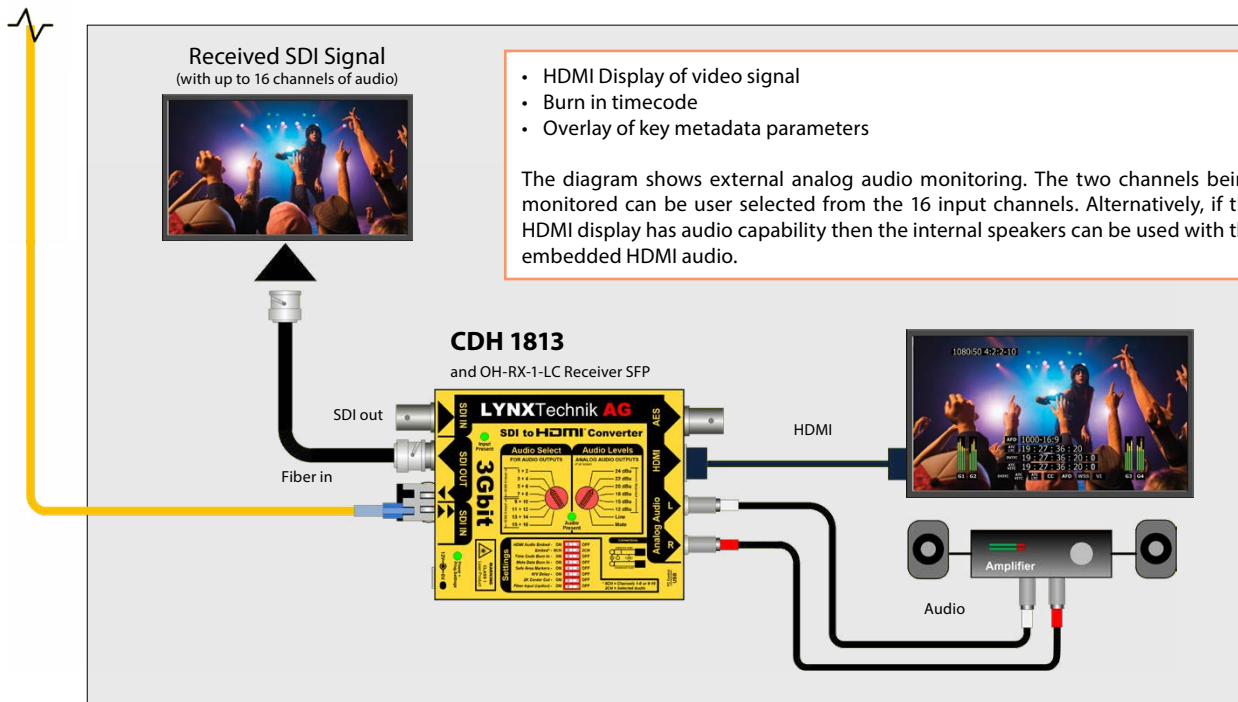

*Distance is an approximation. Actual distances achieved can be longer or shorter depending on the type of cable. Determine link losses and perform optical budget calculations to ensure correct operation.

CDH 1813

3G SDI to HDMI Converter

compatible with

LYNX | Centraal

yelloGUI

Video

Audio

Data

Optical

Racks

Optional

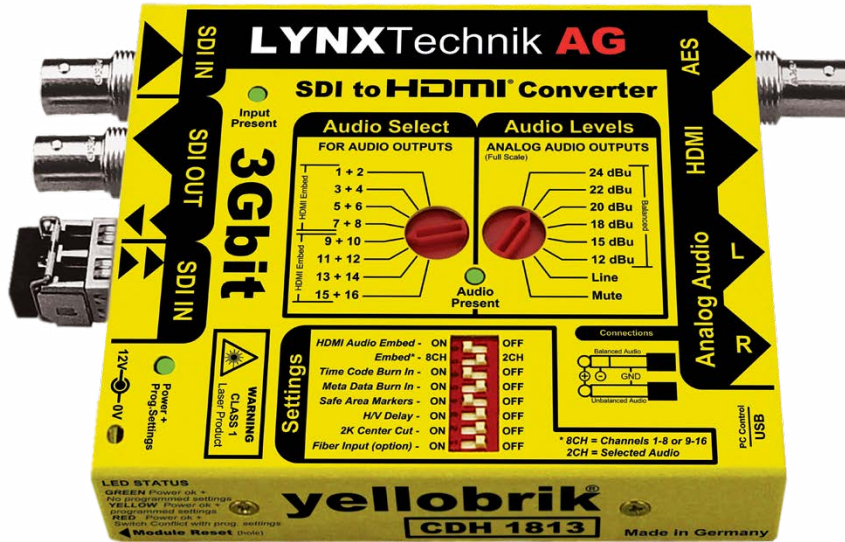

Shown with optional Fiber SFP installed

Visit the product page:



Features

- Support for SDI video inputs up to 3Gbit/s (1080p)
- Supports HDR and WCG indication at HDMI output
- Automated detection of input signal color range via VPID information
- 3G SDI Level A and Level B support
- Support for single link 3D formats
- Automatic input standard and format detection
- Fiber input and output options
- HDMI video output with embedded audio
- Analog and AES audio outputs
- Selectable timecode burn in and Metadata burn in
- 16 channel audio metering
- H/V delay and safe area markers
- yelloGUI and LynxCentraal compatible: Gain access to additional features

Description

The CDH 1813 is a versatile, compact SDI to HDMI converter designed to combat a host of monitoring and display applications in broadcast, post production and pro A/V markets. Convert any SDI video signal, including 3D formats into an HDMI signal for monitoring and display. Fiber connectivity options add SDI fiber transmission and/or SDI fiber reception using the integrated fiber SFP socket.

Two channels of audio can be de-embedded providing digital AES and analog audio outputs. Analog audio outputs have selectable full scale range presets. The two selected audio channels can also be embedded into the HDMI output. Alternatively 8 channels selected from the input signal (channels 1-8 or 9-16) can be embedded into the HDMI output. Various burn in features make the CDH 1813 a true monitoring tool. Individually selectable timecode burn in, 16 channel audio metering, safe area markers and Metadata display are just a few of the on-screen monitoring features.

LynxCentraal and yelloGUI provide support for a wide range of additional settings and features which are accessed using a PC and the USB port on the module.

Technical Specifications

SDI Input	1 x SDI video on 75 Ohm BNC connector SMPTE 424M, SMPTE 292M, SMPTE 259M 3G Level A & B-DL & B-DS according to SMPTE ST 425-1 and ST 425-2 (3D) with image formats 1280 x 720 and 1920 x 1080 Support for 'single link' 3D modes: "side by side", "top-bottom" and "dual stream (SMPTE ST-423-2)" Electrical Return Loss: >15dB from 5MHz to 1.5GHz, >10dB from 1.5GHz to 3GHz Automatic Cable EQ** (Belden 1694A cable) 340m @ 270Mbit/s, 150m @ 1.5Gbit/s, 120m @ 3Gbit/s
Fiber Input	1 x fiber optic SDI input. SMPTE 297M - 2006 (Optional- see fiber options table)
SDI Output	1 x reclocked SDI video output on 75 Ohm BNC connector Electrical Return Loss: >15dB from 5MHz to 1.5GHz, >10dB from 1.5GHz to 3GHz
Fiber Output	1 x reclocked fiber optic SDI output. SMPTE 297M - 2006 (Optional- see fiber options table)
HDMI Output	10 bit HDMI 1.4a support including 3D, deep color and embedded audio Type A connector. 3D modes supported: "side by side" + "top and bottom" + "frame packing" 24bit (3 X 8bit) and 30bit (3 x 10bit) deep color (R,G,B / Y,Cr,Cb / X,Y,Z) 2 or 8 channel audio embedding (selectable)
AES Output	AES3id on 75 Ohm BNC, 2 channels (selectable)
Audio Output	Left and right analog audio using 1/4 inch jack sockets (phono sockets) Balanced mode with 24, 22, 20, 18, 15, 12dBu full scale (selectable) Unbalanced mode with (line level) at -10 dBV 1/4 inch Jack plug (phono) to RCA connection adapters supplied
USB	Standard USB port for PC interface and firmware updates (Mini Type "B" plug)
Power	+12V DC @ 3.7W nominal - (supports 10 - 14V DC input range)
Physical	Size (incl. connections): 138mm x 90mm x 22mm (5.13" x 3.54" x 0.86") Weight: 230g (8.11oz)
Ambient	5 - 40°C (41 - 104°F) 90% Humidity (non condensing)
Model #	CDH 1813 - (EAN# 4250479359833)
Includes	Module, AC power supply, RCA adapters, HDMI + mini USB cable

*Distance is an approximation. Actual distances achieved can be longer or shorter depending on the type of cable. Determine link losses and perform optical budget calculations to ensure correct operation.

Monitoring Features

The CHD 1813 is ideal for regular transparent image monitoring, providing a clean 1:1 HDMI conversion of the SDI input signal. There are also a number of other HDMI monitoring options available. These monitoring modes are activated using the module dip switch and can be used individually or as combined monitoring modes.

Clean Feed



- Direct conversion of input SDI Stream
- The CHD 1813 does not scale the image, therefore the HDMI output format is the same as the native SDI input resolution and frame rate.

Burn in Windows



- Display up to three timecode values (if present) (VITC, LTC, DVITC)
- SDI input format, bit depth and color scheme
- AFD present and format code
- 16 audio level meters
- Closed Caption, WSS and VI metadata presence

Safe Area Markers

- Default: SMPTE Safe Action (default can be changed using yelloGUI or LynxCentraal)
- Center cross marker
- Fully programmable with yelloGUI and LynxCentraal



H / V Delay

- View horizontal and vertical blanking



Parameters

The CHD 1813 features full yelloGUI and LynxCentraal support that provides access to additional features and settings not possible from the module's local controls. Additional settings include:

Parameter	Settings
Safe Area Markers	OFF
	SMPTE Safe Action (90/90)
	SMPTE Safe Title (80/80)
	EBU Action (3.5/3.5)
	EBU Graphics (5/10)
Aspect Ratio Markers	OFF
	4:3
	16:9
Curtain Transparency	100%
	Adjustable 30%-90%
Center Cross	ON
	OFF
Marker Color	White
	Red, Green, Blue, Yellow, Cyan, Magenta, Black
	Safe Area from Aspect
	ON
	OFF

Parameter	Settings	Parameter	Settings	Parameter	Settings	
SDI input RGB Range	SMPTE Limited	HDMI Color Range	SMPTE Limited	Audio Channels	1:1	
	Full Range		Full Range		Convert*	
HDMI Output Bit Depth	AUTO	HDMI Color Space	AUTO	*DEFAULT: Audio channels 1 through 8 are mapped 1:1 from SDI to HDMI. When set to "Convert" channels 3 and 4 are swapped resulting in channel allocations per SMPTE 320M (3=center /4=LFE) and CEA-861 (3=LFE / 4=FrontCenter)		
	8 bit			RGB		
	10 bit			Y,Cr,Cb 4:2:2		
	12 bit		Y,Cr,Cb 4:4:4			
3D HDMI Output Format	AUTO	3D SDI Input Format	AUTO	Swap SDI Streams	Regular	
	Frame Packing (FP)				Inverted	
	Side by Side (SS)			When a 3G LevelB input signal is processed as 3D content then the default setting is: Left Eye from Stream A, and Right Eye from Stream B. This can be inverted with this switch. For 2D content, default is stream A, and stream B is selected with this switch.		
	Top and Bottom (TB)					
3D Flip Left Eye	NO FLIP	3D Flip Right Eye	NO FLIP	Horizontal Flip	NO FLIP	
	Horizontal				FLIP	
	Vertical			This mode flips the input signal horizontally to show a mirror image on the HDMI output. Useful for Virtual Set (Green Screen) on set monitoring.		
	Both					

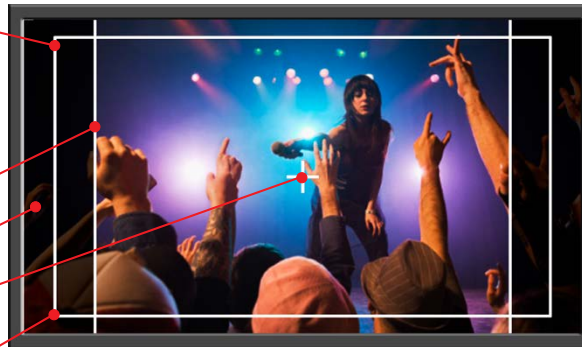

The on screen markers can be custom configured to suit any application. This includes various "standard" safe area markers, aspect ratio markers with adjustable curtain transparency. The color of the markers may also be changed.

Default Settings

*Distance is an approximation. Actual distances achieved can be longer or shorter depending on the type of cable. Determine link losses and perform optical budget calculations to ensure correct operation.

CHD 1412

4K HDMI to 12G-SDI Converter + Frame Synchronizer

compatible with

LYNX | Centraal

yelloGUI

Video

Audio

Data

Optical

Racks

Optional



Shown with optional Fiber SFP Installed

Visit the product page:



Features

- Supports 12G / 6G / 3G / 1.5G / SD-SDI Signals
- 3G-SDI Level A And Level B Support
- Integrated Frame Synchronizer
- Multi-Format Sync Reference Input - Cross Lock Compatible
- 2 x SDI Outputs With Optional SDI Fiber Output
- HDMI Embedded PCM Audio Passes Transparently
- Balanced Analog Audio, Unbalanced Line Level Audio, Or AES Input
- Selectable AES Channel For Embedding External Audio
- HDMI, Reference And Audio Present LED Indication
- LynxCentraal & yelloGUI Compatible For Additional Internal Settings

Description

The CHD 1412 is a versatile and compact HDMI to SDI converter with integrated frame synchronizer. It is an ideal solution for any application which requires a fully synchronized SDI input from an external asynchronous HDMI source.

The flexible reference sync input will accept any analog video sync format including SD bi-level sync, black burst, colorbars and tri-level sync. The sync input is auto detecting and fully cross lock compatible. For example: An SDTV reference can be used to frequency lock an HD HDMI input. If no reference is present, the converter performs a standard asynchronous HDMI to SDI conversion. It can also lock to the HDMI input. A pair of stereo analog inputs can be embedded into any AES channel. Audio inputs can be either professional balanced audio with selectable full scale level, or unbalanced consumer line level audio. By default any PCM audio present in the HDMI stream will be embedded into the SDI output [encoded audio such as AC3 / DD+ etc. is not supported] or it can be replaced with the external audio signals.

The module is also compatible with LynxCentraal and yelloGUI software packages, which provide access to a host of additional internal settings including adjustable video delay for timing purposes.

An SDI fiber output is also provided with a variety of plug in SFP options available.

Note: For legal reasons, HDMI capture devices from LYNX Technik AG are designed not to capture, convert or transmit video or audio from HDCP copy-protected sources (e.g. Satellite receivers, Cable receivers, BD players etc.)

Technical Specifications

HDMI Input	Type A 2.0b connector for up to 2160p60 Up to 8 channels embedded audio in HDMI is passed transparently or replaced with external analog audio input
Reference Input	SDTV: Analog 525 or 625 bi-level sync, black burst or colorbars HDTV, 3G, 12G: All tri-level sync standards (exceptions 1080p 50/59.94/60Hz) Cross lock compatible SMPTE 274M, SMPTE 296M - 75 Ohm BNC connector
Frame Synchronizer	Functional if valid reference is detected, otherwise operates in free run (asynchronous) mode. External audio and HDMI input are frequency locked to external reference, fully cross lock compatible across standards. One frame adjustable delay (in line and pixel increments) using LynxCentraal or yelloGUI
SDI Outputs	2 x SDI video, 75 Ohm BNC (both have the same signal - NOT dual link) SMPTE 259M, SMPTE 292M, SMPTE 424M, SMPTE 2081-1, SMPTE 2082-1 Electrical Return Loss: to 1.5GHz to 3GHz to 6GHz to 12GHz >15dB >10dB >7dB >4dB
Fiber Output	Optional plug in SFP for optical SDI output (see fiber options table) SMPTE 297 - 2006
Audio Inputs	Left and right analog audio using 3.5mm jack plugs 10k Ohm differential balanced input mode with 24,22,20,18,15,12 dBu and User definable full scale level (selectable) Unbalanced mode with (line level) at -10 dBV (3.5mm Jack Plug to RCA connection adapters supplied) Selectable AES channel for audio embedding (1 through 8) (Overwrites any HDMI embedded audio present in selected channel) Frequency response: <+/- 0.1dB 20Hz to 20KHz 48kHz A/D sample rate (frequency locked to SDI output)
Power	+12V DC @ 10.0W (excl. SFP) nominal - (supports 10 - 14V DC input range)
Physical	Size (incl. connectors): 140mm x 90mm x 22mm (5.51" x 3.54" x 0.86") Weight (excl. SFP): 207g (7.3oz)
Ambient	5 - 40°C (41 - 104°F) 90% Humidity (non condensing)
Model #	CHD 1412 - (EAN# 4250479328112)
Includes	Module, AC power supply, RCA adapters, HDMI + USB cable



CAUTION: This is a high power module. If mounting the module in the RFR 1200 rack frame please leave an empty slot each side of the module to allow for adequate airflow to prevent the risk of overheating.

*Distance is an approximation. Actual distances achieved can be longer or shorter depending on the type of cable. Determine link losses and perform optical budget calculations to ensure correct operation.

Resolution and Frame Rate Conversion Details

Video Output Resolution

The module does not have an internal scaler and no de-interlacer. If the input resolution does not match any of the supported SDI formats, the module by default will select an appropriate SDI standard with a similar number of line pixels and map the signal into the SDI output. This may result in some image cropping (cut) or boxing (blanking) of the overshoot area. To change the output format, please connect the module to a PC or Mac via either yelloGUI or LynxCentraal.

HDMI Input	SDI Output				
	SDTV	720p	1080i	1080p	2160p
SDTV [720x 525/625]	N	B	B	B	B
720p [1280x720]	C	N	B	B	B
1080i [1920x1080]	C	C	N	N	B
1080p [1920x1080]	C	C	N	N	B
2160p [3840x2160]	C	C	C	C	N

HDMI Input	SDI Output				
	SDTV	720p	1080i	1080p	2160p
VGA [640x480]	B	B	B	B	B
SVGA [800x600]	C	B	B	B	B
XGA [1024x768]	C	CV/BH	B	B	B
WXGA [1280x768]	C	CV	B	B	B
WUXGA [1920x1200]	C	C	CV	CV	B
WQXGA [2560x1600]	C	C	C	C	B
WQUXGA [3840x2400]	C	C	C	C	CV

Legend		CV/BH	Crop: Vertical / Boxing: Horizontal
C	Cropping (Horizontal and Vertical)	CV	Crop: Vertical
B	Boxing (Horizontal and Vertical)	N	Output = Input

Cross Lock and Frame Rate Conversion

The frame synchronizer is fully cross lock compatible, meaning it can cross lock between different standards. With a given reference signal connected, the synchronizer will drop or repeat frames to achieve a correctly synchronized (frame rate converted) SDI output.

Reference Signal (fps)	SDI Output	Input Video Standard												
		525 i / 59	625 i / 50	1080 i / 50	1080 i / 59	1080 i / 60	16:9 p / 23	16:9 p / 24	16:9 p / 25	16:9 p / 29	16:9 p / 30	16:9 p / 50	16:9 p / 59	16:9 p / 60
23		525 i / 59	525 i / 59	1080 i / 59	1080 i / 59	1080 i / 59	16:9 p / 23	16:9 p / 23	16:9 p / 23	16:9 p / 23	16:9 p / 23	16:9 p / 59	16:9 p / 59	16:9 p / 59
24		625 i / 50	625 i / 50	1080 i / 50	1080 i / 50	1080 i / 50	16:9 p / 24	16:9 p / 24	16:9 p / 24	16:9 p / 24	16:9 p / 24	16:9 p / 50	16:9 p / 50	16:9 p / 50
25/50		625 i / 50	625 i / 50	1080 i / 50	1080 i / 50	1080 i / 50	16:9 p / 25	16:9 p / 25	16:9 p / 25	16:9 p / 25	16:9 p / 25	16:9 p / 50	16:9 p / 50	16:9 p / 50
29/59		525 i / 59	525 i / 59	1080 i / 59	1080 i / 59	1080 i / 59	16:9 p / 29	16:9 p / 29	16:9 p / 29	16:9 p / 29	16:9 p / 29	16:9 p / 59	16:9 p / 59	16:9 p / 59
30/60		625 i / 50	625 i / 50	1080 i / 60	1080 i / 60	1080 i / 60	16:9 p / 30	16:9 p / 30	16:9 p / 30	16:9 p / 30	16:9 p / 30	16:9 p / 60	16:9 p / 60	16:9 p / 60

CHD 1412 Frame Rate Conversion Applications

DROP FRAME CONVERSION

REPEAT FRAME CONVERSION

In North American (or legacy NTSC) markets the HDMI signals from most devices tends to be at the consumer 60Hz frame rate and not 59.94Hz which is the required frame rate for broadcast and production.

The CHD 1412 can be used to solve this problem and convert a 60Hz HDMI signal to a 59.94Hz SDI signal. This is accomplished using the integrated frame synchronizer (which will drop frames to achieve the correct frame rate)

In fact, the module can also convert between 50Hz and 60Hz standards using the frame synchronizer, which is useful for monitoring applications.

It's also possible to precisely adjust the timing of the SDI output up to one full frame relative to the reference sync in pixel and line increments - which is useful for timing and synchronizing SDI sources into production switchers or routers etc.

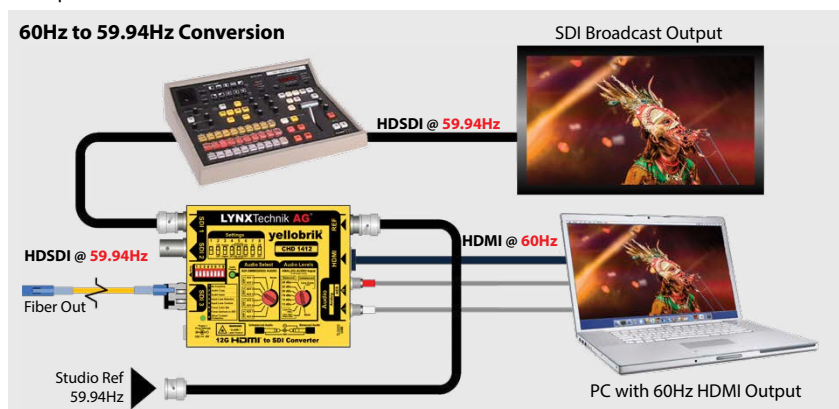

*Distance is an approximation. Actual distances achieved can be longer or shorter depending on the type of cable. Determine link losses and perform optical budget calculations to ensure correct operation.

CHD 1812-1

3G HDMI to SDI Converter + Frame Synchronizer

compatible with

LYNX | Centraal

yelloGUI

Video

Audio

Data

Optical

Racks

Optional

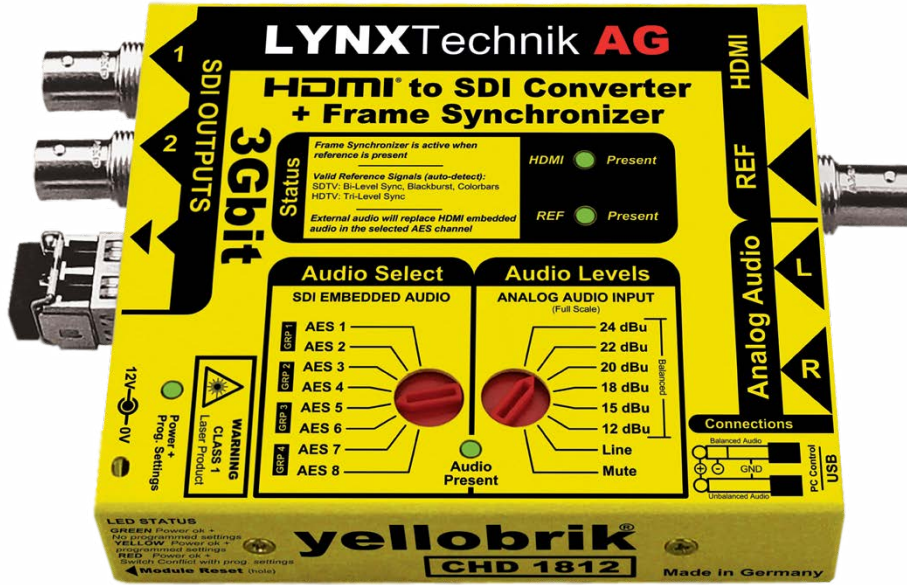

Shown with optional Fiber SFP Installed

Visit the product page:



Features

- SDI video output formats up to 3Gbit (1080p60)
- 3G SDI Level A and Level B support
- Support for single link 3D formats
- Integrated Frame Synchronizer
- Multi-format sync reference input - cross lock compatible
- 2 x SDI outputs with optional SDI fiber output
- HDMI embedded audio passed transparently
- 2 x external analog audio inputs
- Professional balanced analog audio inputs or unbalanced line level audio inputs
- Selectable AES channel for embedding external audio
- HDMI, reference, and audio present LED indication
- LynxCentraal and yelloGUI compatible to access additional internal settings

Description

The CHD 1812-1 is a versatile and compact HDMI to SDI converter with integrated frame synchronizer. It is an ideal solution for any application which requires a fully synchronized SDI input from an external asynchronous HDMI source.

The flexible reference sync input will accept any analog video sync format including SD bi-level sync, black burst, colorbars and tri-level HD sync. The sync input is auto detecting and fully cross lock compatible. For example: An SDTV reference can be used to frequency lock an HD HDMI input. If no reference is present, the converter performs a standard asynchronous HDMI to SDI conversion. A pair of stereo analog inputs can be embedded into any AES channel. Audio inputs can be either professional balanced audio with selectable full scale level, or unbalanced consumer line level audio. By default any audio present in the HDMI stream will be embedded into the SDI output or it can be replaced with the external audio signals.

The module is also compatible with the yelloGUI software package, which provides access to a host of additional internal settings including adjustable video delay for timing purposes.

An SDI fiber output is also provided with a variety of plug in SFP options available.



Technical Specifications

HDMI Input	3D compatible input using type A connector For a detailed list of supported formats please refer to the article in our knowledge base (www.lynx-technik.com > Support > Knowledge Base)
	Up to 8 channels embedded audio in HDMI is passed transparently or replaced with external analog audio input
Reference Input	SDTV: Analog 525 or 625 bi-level sync, black burst or colorbars HDTV: All tri-level sync standards (exceptions 1080p 50/59.94/60Hz) Cross lock compatible
	SMPTe 274M, SMPTe 296M - 75 Ohm BNC connector
Frame Synchronizer	Functional if valid reference is detected, otherwise operates in free run (asynchronous) mode. External audio and HDMI input are frequency locked to external reference, fully cross lock compatible across standards. One frame adjustable delay (in line and pixel increments) using yelloGUI
SDI Outputs	2 x SDI video, 75 Ohm BNC. (both have the same signal - NOT dual link) SMPTe 424M, SMPTe 292M, SMPTe 259M, SMPTe 297M 3G Level A & B-DL & B-DS according to SMPTe ST 425-1 and ST 425-2 (3D) with image formats 1280 x 720 and 1920 x 1080 For a detailed list of supported formats please refer to the article in our knowledge base (www.lynx-technik.com > Support > Knowledge Base)
	Electrical Return Loss: >15dB from 5MHz to 1.5GHz, >10dB from 1.5GHz to 3GHz
Fiber Output	Optional plug in SFP for optical SDI output (see fiber options table) SMPTe 297M - 2006
Audio Inputs	Left and right analog audio using 1/4 inch jack plugs
	10k Ohm differential balanced input mode with 24,22,20,18,15,12 dBu full scale (selectable)
	Unbalanced mode with (line level) at -10 dBV (1/4 inch Jack Plug to RCA connection adapters supplied)
	Selectable AES channel for audio embedding (1 through 8) (Overwrites any HDMI embedded audio present in selected channel)
	Frequency response: <+/- 0.2dB 20Hz to 20KHz
	48kHz A/D sample rate (free run or frequency locked to reference input)
Power	+12V DC @ 4.7W nominal - (supports 10 - 14V DC input range)
Physical	Size: 138mm x 90mm x 22mm (5.43" x 3.54" x 0.86") including connectors Weight: 230g (8.11oz)
Ambient	5 - 40°C (41 - 104°F) 90% Humidity (non condensing)
Model #	CHD 1812-1 - (EAN# 4250479318335)
Includes	Module, AC power supply, RCA adapters, HDMI + USB cable

Note: For legal reasons, HDMI capture devices from LYNX Technik AG are designed not to capture, convert or transmit video or audio from HDCP copy-protected sources (e.g. Satellite receivers, Cable receivers, BD players etc.)

*Distance is an approximation. Actual distances achieved can be longer or shorter depending on the type of cable. Determine link losses and perform optical budget calculations to ensure correct operation.

Resolution and Frame Rate Conversion Details

Video Output Resolution

The SDI output format is automatically selected based on the detected HDMI input resolution. The module does not have an internal scaler, so if the input resolution does not match any of the supported SDI formats then the module will automatically select an appropriate SDI standard with a similar number of lines and pixels and map the signal into the SDI output, which may result in some image cropping (cut) or boxing (blanking)

The table below shows the input to output resolution settings that are applied in AUTOMATIC mode. The yelloGUI interface provides the ability to manually set the output resolution interdependently of the input resolution. For these cases the table below also lists the conversion mode applied to optimally fit the manually selected SDI output format by either cropping or boxing the image (C > Horizontal and Vertical crop, B > Horizontal and Vertical box, V=C / H=B > vertical crop and horizontal box, V=C > vertical crop only).

SDI Output	HDMI Input Resolution								
	SDTV 720 x 525/625	720p 1280x720	1080i 1920x1080	1080p 1920x1080	VGA 640x480	SVGA 800x600	XGA 1024x768	WXGA 1280x768	WUXGA 1920x1200
<auto>	SDTV	720p	1080i	1080p	720p	720p	1080p	1080p	1080p
SDTV	n.a.	C	C	C	V=C / H=B	V=C / H=B	C	C	C
720p	n.a.	n.a.	n.a.	C	B	V=C / H=B	V=C / H=B	V=C	C
1080i	B	B	n.a.	n.a.	B	B	B	B	V=C
1080p	n.a.	B	n.a.	n.a.	B	B	B	B	V=C

Cross Lock and Frame Rate Conversion

The frame synchronizer is fully cross lock compatible, meaning it can cross lock between different standards. With a given reference signal connected the synchronizer will drop or add frames to achieve a correctly synchronized (frame rate converted) SDI output.

Note: This conversion drops and adds frames to achieve the desired output frame rate and will not provide the performance typical of a sophisticated standards converter. Please refer to the tables below for the conversion possibilities. Red = Drop Frame, Yellow = Adding Frames

HDMI inputs with @ 23.98/29.97/59.94Hz Frame Rates

Reference Signal	23.98Hz		24Hz	
	29.97Hz	30Hz	25Hz	25Hz
	59.94Hz	60Hz	50Hz	50Hz
HDMI Input	SDI Output Formats			
525 / 59.94Hz	525 / 59.94Hz	525 / 60Hz	625 / 50Hz	
720p / 59.94Hz	720p / 59.94Hz	720p / 60Hz	720p / 50Hz	
720p / 29.97Hz	720p / 29.97Hz	720p / 30Hz	720p / 25Hz	
720p / 23.98Hz	720p / 23.98Hz	720p / 30Hz	720p / 24Hz	
1080i / 59.94Hz	1080i / 59.94Hz	1080i / 60Hz	1080i / 50Hz	
1080p / 59.94Hz	1080p / 59.94Hz	1080p / 60Hz	1080p / 50Hz	
1080p / 29.97Hz	1080p / 29.97Hz	1080p / 30Hz	1080p / 25Hz	
1080p / 23.98Hz	1080p / 23.98Hz	1080p / 30Hz	1080p / 24Hz	

HDMI inputs with @ 24/30/60Hz Frame Rates

Reference Signal	23.98Hz		24Hz	
	29.97Hz	30Hz	25Hz	25Hz
	59.94Hz	60Hz	50Hz	50Hz
HDMI Input	SDI Output Formats			
525 / 60Hz	525 / 59.94Hz	525 / 60Hz	625 / 50Hz	
720p / 60Hz	720p / 59.94Hz	720p / 60Hz	720p / 50Hz	
720p / 30Hz	720p / 29.97Hz	720p / 30Hz	720p / 25Hz	
720p / 24Hz	720p / 23.98Hz	720p / 30Hz	720p / 24Hz	
1080i / 60Hz	1080i / 59.94Hz	1080i / 60Hz	1080i / 50Hz	
1080p / 60Hz	1080p / 59.94Hz	1080p / 60Hz	1080p / 50Hz	
1080p / 30Hz	1080p / 29.97Hz	1080p / 30Hz	1080p / 25Hz	
1080p / 30Hz	1080p / 23.98Hz	1080p / 30Hz	1080p / 24Hz	

HDMI inputs with @ 25/50Hz Frame Rates

Reference Signal	23.98Hz		24Hz	
	29.97Hz	30Hz	25Hz	25Hz
	59.94Hz	60Hz	50Hz	50Hz
HDMI Input	SDI Output Formats			
625 / 50Hz	525 / 59.94Hz	525 / 60Hz	625 / 50Hz	
720p / 50Hz	720p / 59.94Hz	720p / 60Hz	720p / 50Hz	
720p / 25Hz	720p / 29.97Hz	720p / 30Hz	720p / 25Hz	
1080i / 50Hz	1080i / 59.94Hz	1080i / 60Hz	1080i / 50Hz	
1080p / 50Hz	1080p / 59.94Hz	1080p / 60Hz	1080p / 50Hz	
1080p / 25Hz	1080p / 29.97Hz	1080p / 30Hz	1080p / 25Hz	

DROP FRAME CONVERSION

ADD FRAME CONVERSION

Frame Rate Conversion Applications

In North American (or legacy NTSC) markets the HDMI signals from most devices tends to be at the consumer 60Hz frame rate and not 59.94Hz which is the required frame rate for broadcast and production.

The CHD 1812-1 can be used to solve this problem and convert a 60Hz HDMI signal to a 59.94Hz SDI signal. This is accomplished using the integrated frame synchronizer (which will drop frames to achieve the correct frame rate)

If fact, the module can also convert between 50Hz and 60Hz standards using the frame synchronizer, which is useful for monitoring applications.

Its also possible to precisely adjust the timing of the SDI output up to one full frame relative to the reference sync in pixel and line increments - which is useful for timing and synchronizing SDI sources into production switchers or routers etc.

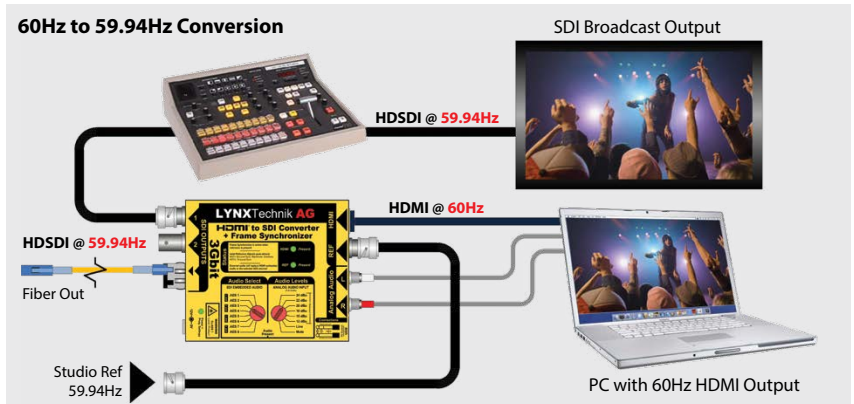

*Distance is an approximation. Actual distances achieved can be longer or shorter depending on the type of cable. Determine link losses and perform optical budget calculations to ensure correct operation.

CHD 1402

4K HDMI to 12 SDI Converter

compatible with

LYNX | Centraal

yelloGUI

Video

Audio

Data

Optical

Racks

Optional



Shown with optional Fiber SFP Installed

Visit the product page:



Features

- Supports 12G / 6G / 3G / 1.5G / SD-SDI Signals
- 3G SDI Level A and Level B support
- 2x BNC and 1x optional Fiber SFP outputs
- 1x HDMI 2.0b input
- HDMI Embedded PCM Audio Passes Transparently
- HDMI present LED indication
- LynxCentraal and yelloGUI compatible for internal settings

Description

The CHD 1402 is a compact HDMI to SDI converter. It is an ideal solution for any application which requires a broadcast quality SDI signal derived from an external HDMI source. Currently only PCM audio present in the HDMI stream will be embedded into the corresponding channels on the SDI output.

The module is also compatible with the yelloGUI and LynxCentraal control software, which provides access to additional internal settings.

An SDI fiber output is also provided with a selection of optional SFPs.

Note: For legal reasons, HDMI capture devices from LYNX Technik AG are designed not to capture, convert or transmit video or audio from HDCP copy-protected sources (e.g. Satellite receivers, Cable receivers, etc.).

Application Example

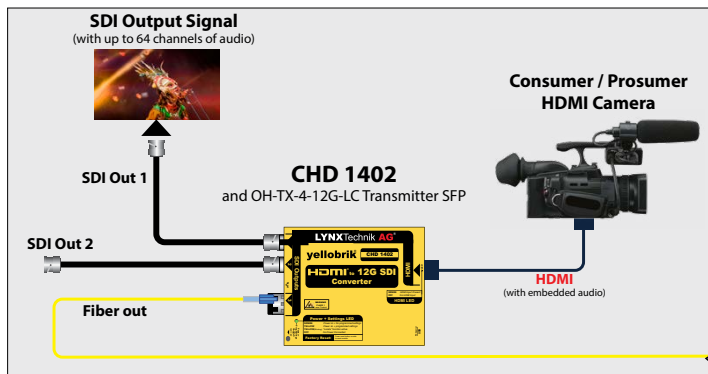

Technical Specifications

HDMI Input	Type A 2.0b connector for up to 2160p60 Up to 8 channels embedded audio in HDMI is passed transparently
SDI Outputs	2 x SDI video, 75 Ohm BNC (both have the same signal - NOT dual link) SMPTE 259M, SMPTE 292M, SMPTE 424M, SMPTE 2081-1, SMPTE 2082-1 Electrical Return Loss: to 1.5GHz >15dB, to 3GHz >10dB, to 6GHz >7dB, to 12GHz >4dB
Fiber Output	Optional plug in SFP for optical SDI output (see fiber options table)
Power	+12V DC @ 9.3W nominal - (supports 10 - 24V DC input range)
Physical	Size (incl. connectors): 123mm x 90mm x 22mm (4.84" x 3.54" x 0.86") Weight: 186g (6.56oz)
Ambient	5 - 40°C (41 - 104°F) 90% Humidity (non condensing)
Model #	CHD 1402 - (EAN# 4250479328129)
Includes	Module, AC power supply, HDMI + USB cable

SDI Fiber Transmitter Options

Model	Description	Power
OH-TX-12G-LC	SFP Fiber TX - Singlemode - LC connector - 10km*	0.5dBm
OH-TX-4-12G-LC	SFP Fiber TX - Singlemode - LC, ST or SC conn. - 40km*	3dBm
OH-TX-12G-XXXX-LC	CWDM SFP Fiber TX - Singlemode LC Conn. - 10km* XXXX=Wavelength. 18 acc. to ITU T G692.2 (1270nm - 1610nm)	3dBm

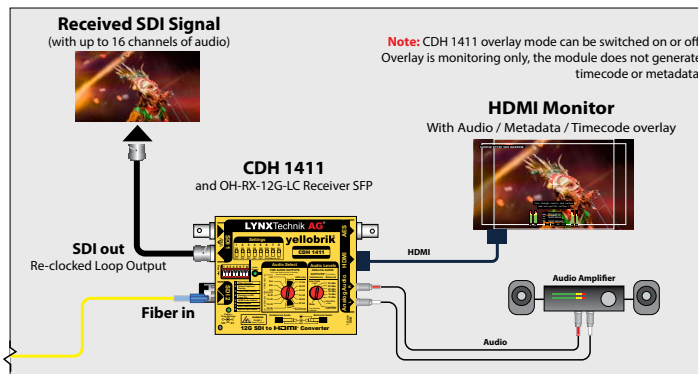

CAUTION: This is a high power module. If mounting the module in the RFR 1200 rack frame please leave an empty slot each side of the module to allow for adequate airflow to prevent the risk of overheating.

*Distance is an approximation. Actual distances achieved can be longer or shorter depending on the type of cable. Determine link losses and perform optical budget calculations to ensure correct operation.

CHD 1802-1 3G HDMI to SDI Converter

compatible with

LYNX | Centraal™

yelloGUI



Shown with optional Fiber SFP Installed

Visit the product page:



Features

- SDI video output formats up to 3Gbit (1080p60)
- 3G SDI Level A and Level B support
- Support for single link 3D formats
- 2 x SDI outputs
- Optional SDI fiber output
- HDMI embedded audio passed transparently
- HDMI present LED indication
- yelloGUI and LynxCentraal compatible to access additional internal settings

Description

The CHD 1802-1 is a compact HDMI to SDI converter. It is an ideal solution for any application which requires a broadcast quality SDI signal derived from an external HDMI source. Any audio present in the HDMI stream will be embedded into the corresponding channels on the SDI output. The module is also compatible with yelloGUI and LynxCentraal providing access to a wide range of additional internal settings.

The SDI output format is automatically selected based on the detected HDMI input resolution. **If the input resolution does not match any of the supported SDI formats** the module will automatically select a SDI standard with a similar number of lines and pixels, and map the signal into the SDI output (Refer To **APPENDIX I** for More Information)

An SDI fiber output is also provided with a variety of plug in SFP options available.

Note: For legal reasons, HDMI capture devices from LYNX Technik AG are designed not to capture, convert or transmit video or audio from HDCP copy-protected sources (e.g. Satellite receivers, Cable receivers, etc.).

SFP Module Options

Wavelength [XXXX = Wavelength in options]	SDI	Max. Distance*	Option #	Description	TX Power
1310nm	3Gbit/s	10km*	OH-TX-1-LC / ST / SC	TX Fiber SFP - Singlemode - LC, ST or SC connection	-5dBm
1270 - 1610 nm (18 wavelengths in 20nm increments)	3Gbit/s	40km*	OH-TX-4-XXXX-LC	CWDM Fiber SFP - Singlemode - LC Connection	-1dBm

*Distance is an approximation. Actual distances achieved can be longer or shorter depending on the type of cable. Determine link losses and perform optical budget calculations to ensure correct operation.

Technical Specifications

HDMI Input	3D compatible input using type A connector Up to 8 channels embedded audio in HDMI is passed transparently
SDI Outputs	2 x SDI video, 75 Ohm BNC. (both have the same signal - NOT dual link) SMPTE 424M, SMPTE 292M, SMPTE 259M 3G Level A & B-DL & B-DS according to SMPTE ST 425-1 and ST 425-2 (3D) with image formats 1280 x 720 and 1920 x 1080 For a detailed list of supported formats please refer to the article in our knowledge base (www.lynx-technik.com > support > tech.support) Electrical Return Loss: >15dB from 5MHz to 1.5GHz, >10dB from 1.5GHz to 3GHz
Fiber Output	Optional plug in SFP for optical SDI output (see fiber options table)
Power	+12V DC @ 4W nominal - (supports 10 - 14V DC input range)
Physical	Size (incl. connections): 123mm x 90mm x 22mm (4.84" x 3.54" x 0.86") Weight: 175g (6.17oz)
Ambient	5 - 40°C (41 - 104°F) 90% Humidity (non condensing)
Model #	CHD 1802-1 - (EAN# 4250479318328)
Includes	Module, AC power supply, HDMI + USB cable

CHD 1802 DD+ Variants

Option #	Description
CHD 1802-DD+	Compressed Audio-Format: Data-type 21/0 - Enhanced AC-3 Burst Length 6144
CHD 1802-DD+ Pro	Compressed Audio-Format: Data-type 21/0 - Enhanced AC-3 Burst Length 6144 Enhanced Audio-Format: Data-type 16/0 - ATRAC-X Burst Length 2048

CQS 1462

Bidirectional 2SI/SQD Quad Link ► Single Link Converter

compatible with

LYNX | Centraal

yelloGUI

Video

Audio

Data

Optical

Racks

Optional



Shown with optional Fiber SFP Installed

Visit the product page:



Features

- Support for 12G/6G/3G/1.5G-SDI Video Formats
- 12G-SDI 2SI/SDQ and 6G-SDI Conversion in both directions [Single ► Quad Link / Quad ► Single Link]
- 12G/6G/3G/1.5G Distribution Mode 1►5+1 [BNC ► 5xBNC + 1xSFP* / SFP* ► 5xBNC]
- Automatic Link Loss Reply Options for 2SI/SQD
- Quad Link 12G-SDI to Single Link Fiber*
- Single Link Loopback Output
- 5x BNC and 1x Fiber Output*
- 4x BNC and Fiber Input*
- LynxCentraal & yelloGUI compatible for additional internal settings

Description

The CQS 1462 is a compact solution designed to bridge 6G/12G SDI Quad Link 2SI/SQD devices and Single Link 1.5G/3G/6G/12G SDI devices.

Conversion modes include:

- Single Link to Quad Link (2SI)
[1x12G-SDI ► 4x3G-SDI Level A / 1x6G-SDI ► 4x1.5G-SDI]
- Single Link to Quad Link (SQD)
[1x12G-SDI ► 4x3G-SDI Level A / 1x6G-SDI ► 4x1.5G-SDI]
- Quad Link (2SI) to Single Link
[4x3G-SDI Level A ► 1x12G-SDI / 4x1.5G-SDI ► 1x6G-SDI]
- Quad Link (SQD) to Single Link
[4x3G-SDI Level A ► 1x12G-SDI / 4x1.5G-SDI ► 1x6G-SDI]
- Auto Quad Link to Single Link
- Distribution Amplifier mode (1►5+1)
[1.5G / 3G / 6G / 12G -SDI]

Operational mode can be selected from the local rotary switch or via the LynxCentraal or yelloGUI control software. The CQS 1462 can also be used as a 1►5+1 distribution amplifier if needed. Link identification is possible through on-screen overlays which can be helpful for connectivity problems or link loss.

The module is suitable for all SMPTE standard signals from 1.5G-SDI to 12G SDI (SMPTE 292M, 424M, 2081 and 2082). For optical inputs and outputs, we offer optional SDI SFPs, in both CWDM and non-CWDM variants.

Technical Specifications

SDI I/O	1 x dedicated SDI video input on BNC connector				
	2 x dedicated SDI video output on BNC connector (1 x Loop/Processed output)				
	3 x switchable SDI video in-/outputs on BNC connector				
	SMPTE 292M, SMPTE 424M, SMPTE 2081-1, SMPTE 2082-1				
	Multi-standard operation from 1.5G to 12G 720p (23.98/24/25/29.97/30/50/59.94/60 Hz)** 1080psf (23.98/24/25/29.97/30 Hz)** 1080i (50/59.94/60 Hz)** 1080p (23.98**/24**/25**/29.97**/30**/50/59.94/60 Hz) 2160p (23.98/24/25/29.97/30/50/59.94/60 Hz)				
Electrical Return Loss	to 1.5GHz	to 3GHz	to 6GHz	to 12GHz	
	>15dB	>10dB	>7dB	>4dB	
Automatic Cable EQ*	1.5Gbit/s	3Gbit/s	6Gbit/s	12Gbit/s	
	200m	150m	90m	85m	
		Belden 1694A	Belden 4794R		
Fiber I/O	1 x fiber optic input and output (optional, see table) SMPTE 297M - 2006				
Power	+12VDC @ 13.24W nominal (incl. SFP) - (7-24VDC input range)				
Physical	Size (incl. connectors): 140mm x 90mm x 22mm (4.96" x 3.54" x 0.86") Weight (excl. SFP): 200g (7.05oz)				
Ambient	5 - 40°C (41 - 104°F) 90% Humidity (non condensing)				
Model #	CQS 1462 - (EAN# 4250479327832)				
Includes	Module, AC power supply				



CAUTION: This is a high power module. If mounting the module in the RFR 1200 rack frame please leave an empty slot each side of the module to allow for adequate airflow to prevent the risk of overheating.

*Distance is an approximation. Actual distances achieved can be longer or shorter depending on the type of cable. Determine link losses and perform optical budget calculations to ensure correct operation.

Application Examples

CQS 1462 in Distribution Mode

You may have a 4K camera (or another source device) which has a quad 2SI 4K UHD output which you would like to convert to a standard single link 12G SDI signal. Likewise, you may have a disk recorder or other device which requires a quad 2SI input, and you only have a 12G source. These basic "bridge" modes are the most simple and most common applications of the module.

You can also use CQS 1462 for distributing one 3G/HD signal from Input 1 [BNC/SFP] and distribute it to output 1-4 as well as loop out.

Basic Fiber Applications

Because of the distance limitations using coaxial cable for 12G SDI, using fiber makes a lot of sense. The CQS 1462 is equipped with an integrated SFP port which can accept several fiber options which expands the distance of the 12G SDI signal. Likewise, you can also extend the distance of a native Quad 2SI signal using fiber if needed. (Note: additional LYNX Technik Fiber conversion modules are shown in some applications)

A fiber Transceiver option is also available. This includes both a Transmitter and

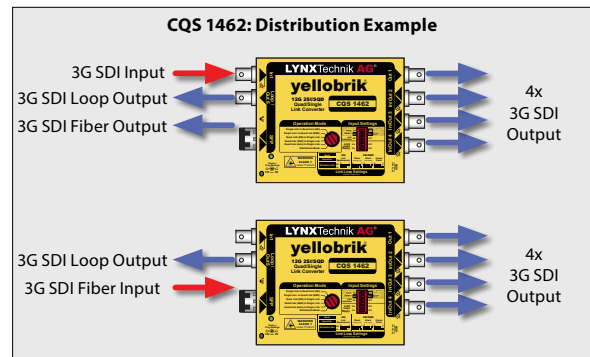
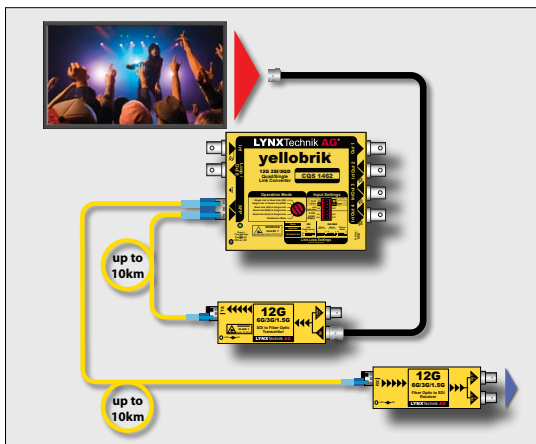

Receiver in a single SFP package. The receive and transmit functions cannot be used simultaneously, but this option is useful if the CQS 1462 configuration is frequently changed where fiber transmission is sometimes needed and on other occasions fiber reception.

Note: Max distances quoted are only approximations based on nominal fiber links. Actual distances achieved can be shorter or longer than that stated. Many things can impact distance such as splices, connections, patches, splitters and the quality of the fiber. For longer distances you should always calculate the total fiber losses in the fiber link and ensure adequate optical budget.

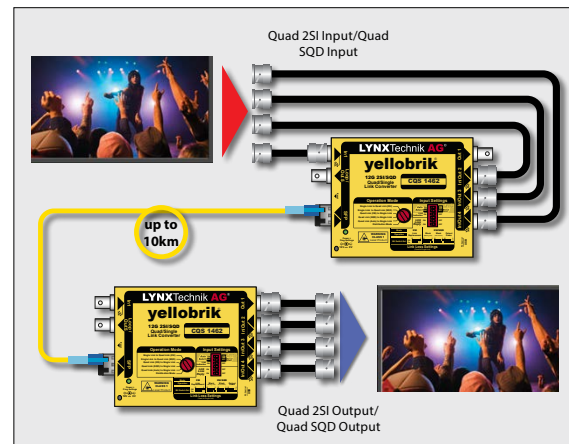

CWDM Fiber Applications

Using the available 12G SDI CWDM fiber transmitter options with the CQS 1462 opens up a whole host of additional possibilities for more complex system designs combining multiple signals into a single fiber link, unidirectional and even bi-directional over a single link. Quad link 2SI and 12G can be combined

with ethernet, serial data and even additional SDI signals if needed. There are too many possibilities to show them all, but below are a few which show the versatility of CWDM fiber when used with the CQS 1462.

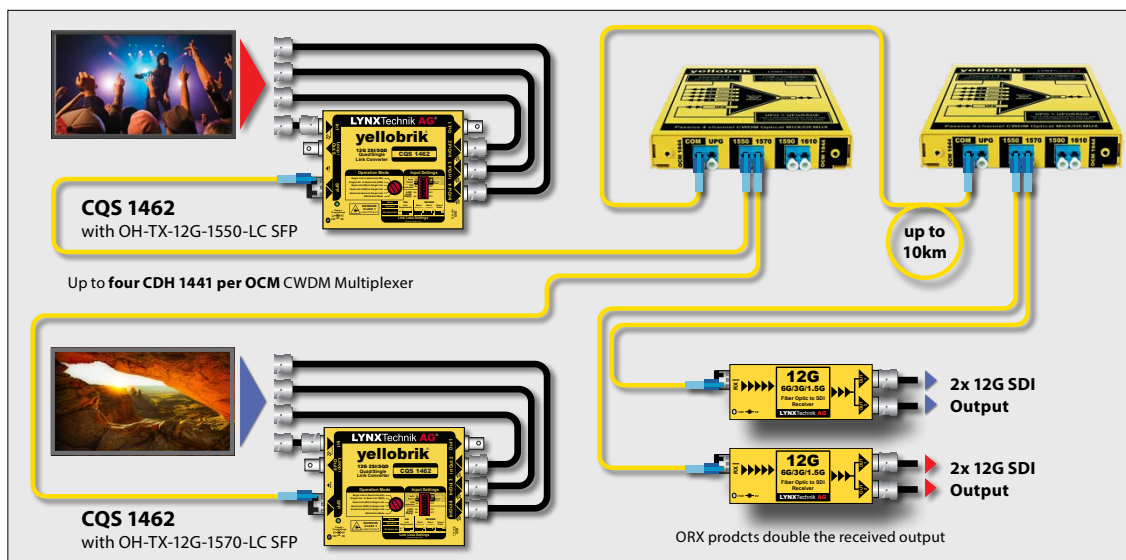

*Distance is an approximation. Actual distances achieved can be longer or shorter depending on the type of cable. Determine link losses and perform optical budget calculations to ensure correct operation.

compatible with

LYNX | Centraal

yelloGUI

Video

Audio

Data

Optical

Racks

Optional



Visit the product page:



Features

- 4 x SDI inputs and 1 x HDMI output
- Support for SDI 3G (level A + B)/HD/SD formats (auto-detect)
- Full Screen, Quad Split and 4K (12G) monitoring modes
- Integrated local control and on screen menus
- Multiple on screen monitoring tools for each input:
 - » *Waveform Monitor*
 - » *Vectorscope*
 - » *Auto Level Meters (upto 16 Channels)*
 - » *IMD (text ID)*
 - » *Safe Area /4:3 Extraction / Center Cross markers*
 - » *Video Standard*
 - » *Time Code*
 - » *Audio and Video Alarms*
- Integrated test signal generator
- 4k (12G) monitoring mode (down converted HD HDMI output)
- yelloGUI and LynxCentraal compatible for PC/MAC control

Description

The PMV 1841 is a compact quad split multiviewer ideal for applications needing basic quad split multi-view capability into an HDMI monitor. Four SDI inputs are supported with a single HDMI output.

The module has three basic modes of operation:

The module is simple to set up and configure using the integrated local control and on screen menu system. All settings are automatically stored in flash RAM.

- **Quad Split** - All four inputs are arranged into a fixed quad display. Each input can have the monitoring tools (or on screen overlays) individually configured.
 - **Full Screen** - One of the four inputs is displayed full screen with the user configured monitoring tools. In this mode 2 channels embedded audio from the selected SDI input is embedded into the HDMI output.
 - **4k Monitoring** - The module can be used to monitor 4K (12G) signals. The four SDI inputs are "stitched" together to make a full frame for monitoring. The 4K image is down converted to HD for display (4K monitor not required)
- Note:** There are no on screen monitoring tools available in 4K mode

A USB port is provided for firmware updates and also PC/MAC control.

Technical Specifications

SDI Inputs	4 x SDI inputs on 75 Ohm BNC connectors (LED for signal present) SMPTE 424M, SMPTE 292M, SMPTE 259M 3G Level A & B-DL according to SMPTE ST 425-1 with image formats 1280 x 720 and 1920 x 1080 For a detailed list of supported formats please refer to the article in our knowledge base: support.lynx-technik.com Electrical Return Loss: >15dB from 5MHz to 1.5GHz, >10dB from 1.5GHz to 3GHz Cable EQ*: 340m@270Mbits / 150m@1.5Gbits / 120m@3Gbits
HDMI Output	1 x HDMI output (Type A Connector) HDMI standard: 1.4a 2 embedded audio channels are passed if "FULL" is selected input
Local Control	On screen menu system accessed using rotary push encoder
USB	Mini "Type B" USB port for firmware updates and control
Power	+12V DC @ 4.9W nominal - (supports 7 - 24V DC input range)
Physical	Size (incl. connectors): 138mm x 90mm x 22mm (5.13" x 3.54" x 0.86") Weight: 230g (8.11oz)
Ambient	5 - 40°C (41 - 104°F) 90% Humidity (non condensing)
Model #	PMV 1841 - (EAN# 4250479323506)
Includes	Module, AC power supply, HDMI cable, mini USB cable



CAUTION: This is a high power module. If mounting the module in the RFR 1200 rack frame please leave an empty slot each side of the module to allow for adequate airflow to prevent the risk of overheating.

*Distance is an approximation. Actual distances achieved can be longer or shorter depending on the type of cable. Determine link losses and perform optical budget calculations to ensure correct operation.

Information on the Available Burn-In Options

Details on Burn-In Options

The extensive on screen monitoring tools are what really sets the PMV 1841 apart from the rest. Despite the very compact size and low price, we have included many high end monitoring tools typically only found in larger multiviewer systems. These include:

- Waveform Monitor
- Vectorscope
- Auto Level Meters (upto 16 Channels)
- IMD - In Monitor Display (text ID)
- Safe Area Markers
- 4:3 Extraction Markers
- Center Cross Marker
- Video Standard
- Time Code
- Audio and Video Alarms

Each of the four inputs can be individually configured to meet specific

monitoring requirements for the application, and all of the on screen tools are easily controlled using the integrated menu system and rotary push encoder.

The on screen menu system is intuitive and simple to use and all settings are automatically stored in flash RAM.

The module is also fully compatible with yelloGUI and LynxCentraal for full control and configuration via the USB port using a PC or MAC.

Application Example



Burn-In Positioning



Note: The above screen capture is from a full screen image and shows all of the possible screen overlays. Some can be configured in terms of size and screen position. The video and audio alarms are not shown, and will appear as text on the screen when an alarm condition is triggered.
 [Video alarms will trigger on "Black" and "No Signal" (video missing). Audio Alarms will trigger on "Silence" and "No Signal" Audio Missing]

*Distance is an approximation. Actual distances achieved can be longer or shorter depending on the type of cable. Determine link losses and perform optical budget calculations to ensure correct operation.

compatible with

LYNX | Centraal

yelloGUI

Video

Audio

Data

Optical

Racks

Optional



Shown with optional Fiber SFP installed

Visit the product page:



Features

- Supports SDI 12G/6G/3G (level A+B)/HD/SD formats (auto-detect)
- Converts between 3G Level A and B Dual Link or vice versa
- Optional fiber I/O
- Robust “flywheel” synchronization for problematic sources
- “Cross lock” compatible reference input
- Integrated test pattern generator
- Up to 30 frames of programmable delay

Description

The PVD 1400 is a broadcast quality compact SDI frame synchronizer for professional applications in the Broadcast, Post Production and Pro AV industry.

The frame synchronizer utilizes robust “flywheel” algorithms that will accommodate a wide variety of low quality asynchronous SDI sources. All embedded audio is extracted and delayed automatically to match the video processing delay. The module also provides up to 30 frames of programmable output delay, adjustable in frames, lines and pixels.

The module is fully compatible with the yelloGUI and LynxCentraal, so the module can be configured, controlled and updated using a PC or MAC.

GPI Connectors

The PVD 1400 has 4 GPI connectors split into four sense and ground pairs. Bridging these connections forces the corresponding settings to apply, overwriting settings set via LynxCentraal or yelloGUI. By default the connections are open.

Input Switchover	In 1	Open	BNC In
		Closed	SFP In
Force Freeze	In 2	Open	Do not Freeze Output
		Closed	Freeze Output

Technical Specifications

Supported Formats	SD	525i	59.94
	SD	625i	50
	HD	720p	23.98, 24, 25, 29.97, 30, 50, 59.94, 60
	HD	1080i	50, 95.94, 60
	HD	1080psf	23.98, 24, 25
	HD A	1920x1080p	23.98, 24, 25, 29.97, 30, 47.95, 48, 50, 59.94, 60
	HD B-DL	1920x1080p	47.95, 48, 50, 59.94, 60
	2K	2084x1080p	23.98, 24, 25, 29.97, 30, 47.95, 48, 50, 59.94, 60
	2K B-DL	2048x1080p	47.95, 48, 50, 59.94, 60
	UHD	3840x2160p	23.98, 24, 25, 29.97, 30, 47.95, 48, 50, 59.94, 60
4K	4096x2160p	23.98, 24, 25, 29.97, 30, 47.95, 48, 50, 59.94, 60	
Supported Standards	SMPTE 259M, SMPTE 292M, SMPTE 424M, SMPTE 2081-1, SMPTE 2082-1		
Color Precision	YCbCr 4:2:2 10-bit		
SDI Input	1 x 75 Ohm BNC electrical SDI input + 1 x optional fiber SDI input		
	Automatic cable EQ	SD: 340m	HD: 140m 3G:130m 12G: 80m
SDI Outputs	2 x SDI video, 75 Ohm BNC (both have the same signal - NOT dual link)		
Electrical Return Loss:	Input	to 1.5GHz	to 3GHz
	Output	>15dB	>10dB
			>7dB
			>4dB
Fiber In-/Output	Optional plug in SFP for optical SDI in-/output (see fiber options table) SMPTE 297 - 2006		
Reference Input	SDTV: Analog 525 or 625 bi-level sync, black burst or colorbars HDTV: All tri-level sync standards SMPTE 274M, SMPTE 296M - 75 Ohm BNC connector		
Frame Synchronizer	Valid reference recommended, otherwise operates in free run (async) mode. Fully cross lock compatible across standards. Up to one frame adjustable delay (line & pixel) using LynxCentraal or yelloGUI		
Power	+12V DC @ 10.0W (excl. SFP) nominal - (supports 10 - 24V DC input range)		
Physical	Size (incl. connectors): 140mm x 90mm x 22mm (5.51" x 3.54" x 0.86")		
	Weight (excl. SFP): 207g (7.3oz)		
Ambient	5 - 40°C (41 - 104°F) 90% Humidity (non condensing)		
Model #	PVD 1400 - (EAN# 4250479329478)		
Includes	Module, AC power supply		

*Distance is an approximation. Actual distances achieved can be longer or shorter depending on the type of cable. Determine link losses and perform optical budget calculations to ensure correct operation.

Application Examples

3G Level A to Level B Dual Link Conversion (or vice versa)

The PVD 1400 frame synchronizer is also a 3G Level A and Level B Dual Link converter. This is especially convenient since broadcast equipment is typically only compatible with either Level A or Level B. 3G Level A and Level B Dual Link are not compatible with each other, therefore making the PVD 1400 Frame Synchronizer + Converter an invaluable problem solver.

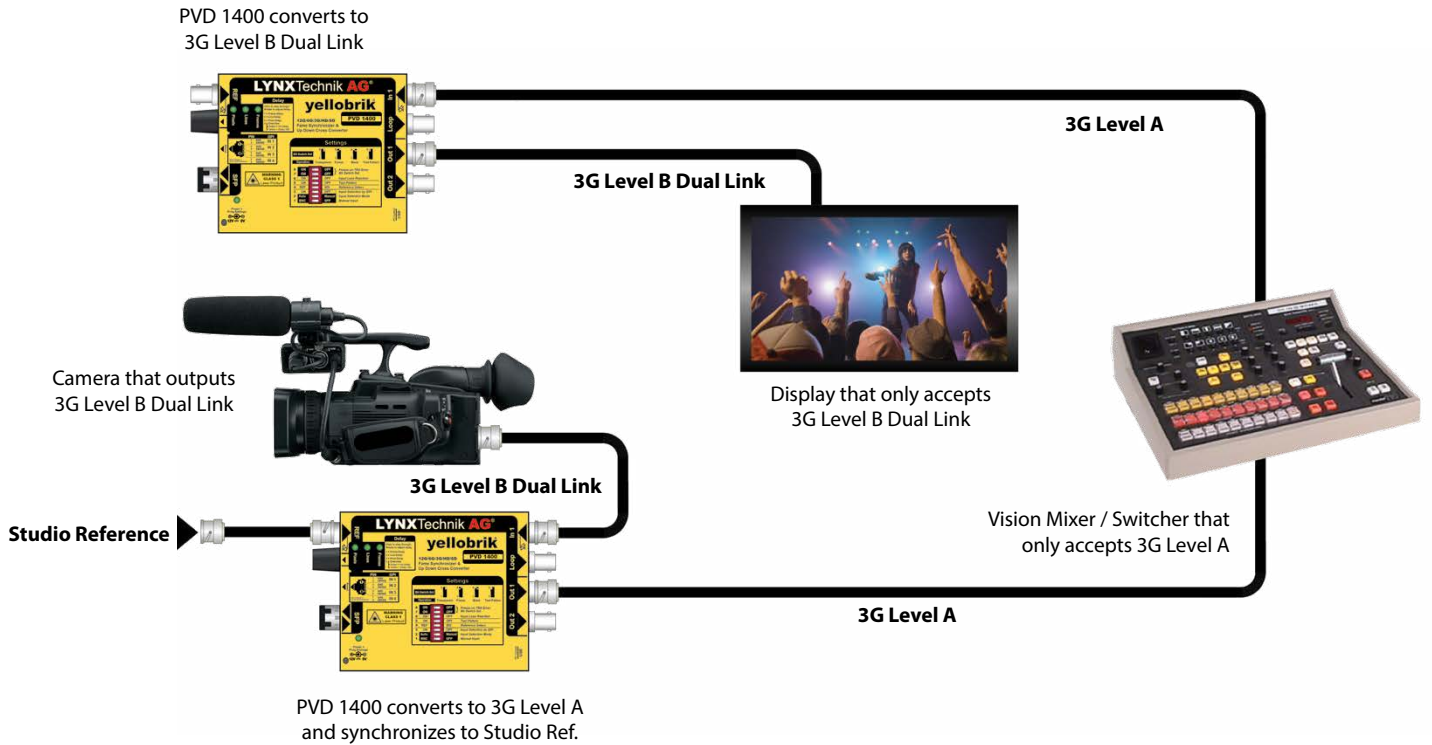

Fiber Options

Model	Description		
SDI Fiber Transceiver Options		Power	Sensitivity
OH-TR-12G-LC	SFP Fiber RX/TX - Singlemode, LC connector - 10km	-5...+0.5 dBm	-10dBm (12G/6G) / -14dBm (3G/1.5G)
OH-TR-1-LC	SFP Fiber RX/TX - Singlemode, LC connector - 10km	-5dBm	-16dBm
OH-TR-0-850-MM	SFP Fiber RX/TX - Multimode, LC connector - 300m	-5dBm	-15dBm
SDI CWDM Fiber Transceiver Options		Power	Sensitivity
XXXX=Wavelength. 18 according to ITU T G692.2 1270 - 1610nm			
OH-TR-12G-XXXX-LC	12G CWDM SFP Fiber RX/TX - Singlemode LC conn. - 10km	-2...+3 dBm	-15dBm
OH-TR-4-XXXX-LC	3G CWDM SFP Fiber RX/TX - Singlemode LC conn. - 40km	-1dBm	-20dBm
SDI Fiber Transmitter Options		Power	
OH-TX-1-LC / ST / SC	SFP Fiber TX - Singlemode - LC, ST or SC conn. - 10km - (1310nm)	-5dBm	
SDI Fiber Receiver Options		Sensitivity	
OH-RX-1-LC / ST / SC	SFP Fiber RX - Singlemode - LC, ST or SC connector	-18dBm	

*Distance is an approximation. Actual distances achieved can be longer or shorter depending on the type of cable. Determine link losses and perform optical budget calculations to ensure correct operation.

compatible with

LYNX | Centraal

yelloGUI

Video

Audio

Data

Optical

Racks

Optional

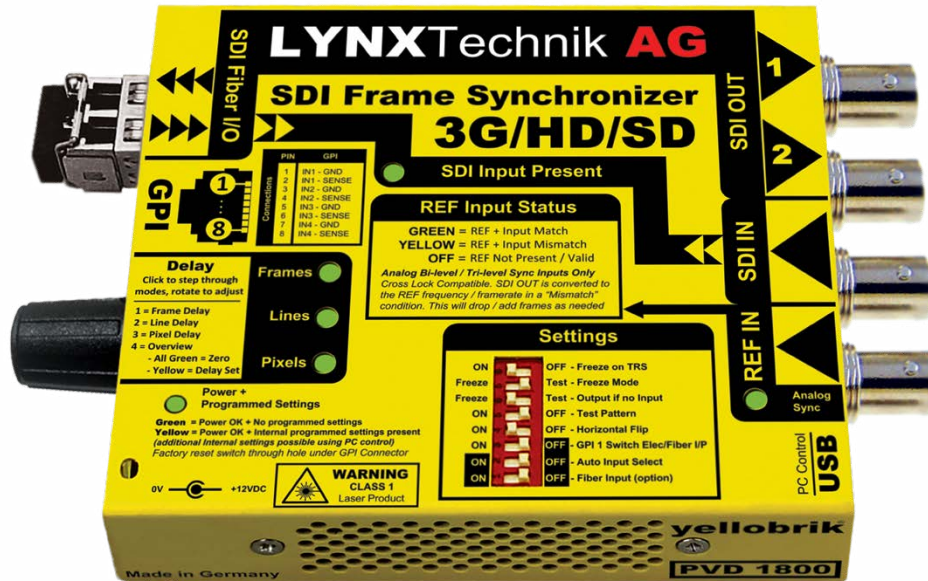

Shown with optional Fiber SFP installed

Visit the product page:



Features

- Supports SDI 3G (level A+B)/HD/SD formats (auto-detect)
- Up/Down/Cross Converter with selectable fast scale mode
- Converter automated by AFD, WSS or VI mode
- Region of Interest scaler
- Converts between 3G Level A and B Dual Link or vice versa
- Optional fiber I/O
- Auto changeover or GPI switch between electrical and optical input
- Robust “flywheel” synchronization for problematic sources
- “Cross lock” compatible reference input
- All 16 channels of audio de-embedded from SDI input
- Audio delayed to match video processing delay and re-embedded
- Integrated test pattern generator
- Up to 30 frames of programmable delay (for timing)

Description

The PVD 1800 is a broadcast quality compact SDI frame synchronizer with high quality Up/Down/Cross converter and scaler for professional applications in the Broadcast, Post Production and Pro A/V industry.

The frame synchronizer utilizes robust “flywheel” algorithms that will accommodate a wide variety of low quality asynchronous SDI sources. All embedded audio is extracted and delayed automatically to match the video processing delay. The module also provides up to 30 frames of programmable output delay, adjustable in frames, lines and pixels.

The Up/Down/Cross converter can convert between 3G/HD/SD video standards and has a selectable fast scale mode (<10 lines delay). In addition, the converter has a powerful Region of Interest (ROI) scaler that allows the user to extract a specific region of the incoming video and to output this as a full format SDI output.

The module is fully compatible with yelloGUI and LynxCentral for configuration, control and updates using a PC or MAC.

Note: Please see the datasheet for more details on Cross Lock and Frame Rate Conversion.

Technical Specifications

SDI Input	1 x 75 Ohm electrical SDI input + 1 x optional fiber SDI input SMPTE 292M, 424M, 259M SMPTE 424M, SMPTE 292M, SMPTE 259M, 3G Level A & B-DL & B-DS (acc. to SMPTE ST 425-1 with image formats 1280 x 720 and 1920 x 1080) Electrical Return Loss: >15dB from 5MHz to 1.5GHz, >10dB from 1.5GHz to 3GHz
SDI Outputs	2 x 75 Ohm electrical SDI outputs SMPTE 292M, 424M, 259M Electrical Return Loss: >15dB from 5MHz to 1.5GHz, >10dB from 1.5GHz to 3GHz Timing Jitter: <0.2 UI @ 270Mbit/s, <1.0 UI @ 1.5Gbit/s, <2.0 UI @ 3Gbit/s Alignment Jitter: <0.2 UI @ 270Mbit/s, <0.2 UI @ 1.5Gbit/s, <0.3 UI @ 3Gbit/s Automatic Cable EQ* (Belden 1694A cable) 340m @ 270Mbit/s, 150m @ 1.5Gbit/s, 110m @ 3Gbit/s
Fiber I/O	Optional plug in SFP for optical SDI I/O (see fiber options table) SMPTE 297M - 2006
Reference Input	SDTV: Analog 525 or 625 bi-level sync HDTV: Tri-level sync standards (except: 1080p 50/59.94/60Hz) Cross lock compatible SMPTE 274M, SMPTE 296M - 75 Ohm BNC connector
Video Delay	Timing Adjustment: Up to 30 frames. Manually adjustable in frame / line / pixel increments
GPI	Connector: RJ45 with 4 x External GPI inputs: GPI 1 - used for Electrical / Optical SDI changeover GPI 2 - used to “freeze” the SDI output GPI 3 - (low) enable “latch” mode GPI 4 - (low) disables “latch” mode
USB	Mini “Type B” to connect to PC or MAC
Power	+12V DC @ 5.8W nominal (without SFP) (supports 7 - 24V DC input range)
Physical	Size (incl. connectors): 138mm x 90mm x 22mm (5.43” x 3.54” x 0.86”) Weight: 230g (8.11oz)
Ambient	5 - 40°C (41 - 104°F) 90% Humidity (non condensing)
Model #	PVD 1800 - (EAN# 4250479324596)
Includes	Module, AC power supply, mini USB cable

*Distance is an approximation. Actual distances achieved can be longer or shorter depending on the type of cable. Determine link losses and perform optical budget calculations to ensure correct operation.

Application Examples

Up/Down/Cross Converter and Scaler

The PVD 1800 includes an integrated broadcast quality Up/Down/Cross Converter that converts between 3G, HD and SD formats. The converter uses the same state of the art technology that is used in the greenMachine™ products. A selectable fast scale mode will deactivate the frame synchronizer and can reduce the processing delay to less than 10 lines, a fraction of a frame*. In addition, the converter can be automated by the incoming format description of the SDI (AFD, WSS or VI).

* For a detailed list of processing delays in fast scale mode please refer to the correlating article in our knowledge base: support.lynx-technik.com

Cross convert between HD and 3G standards

With the cross conversion functionality of the PVD 1800 can convert between 720p, 1080i and 1080p resolutions.

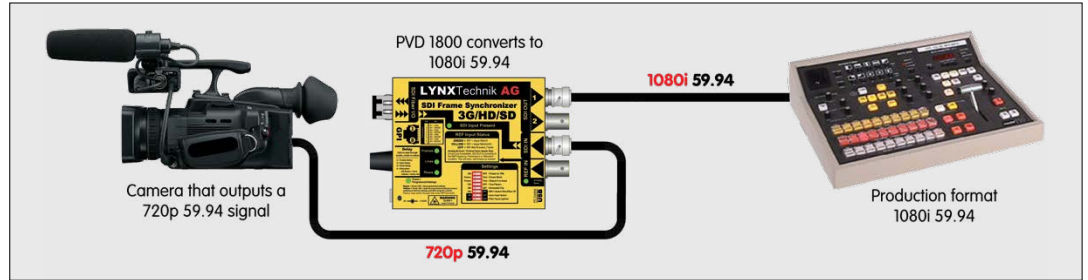

Convert between SD & 3G HD with aspect ratio conversion

The PVD 1800 can up or down convert between SD SDI and 3G/HD and will aspect ratio convert if required.

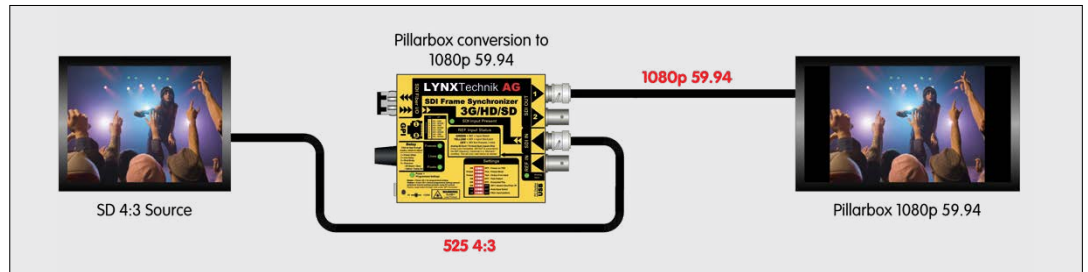

Region of Interest (ROI) scaler

The scaler of the PVD 1800 allows for a Region of Interest (ROI) selection. The user can select any region of the incoming video signal for output as a full video signal. The size and position of the output image can be freely adjusted.

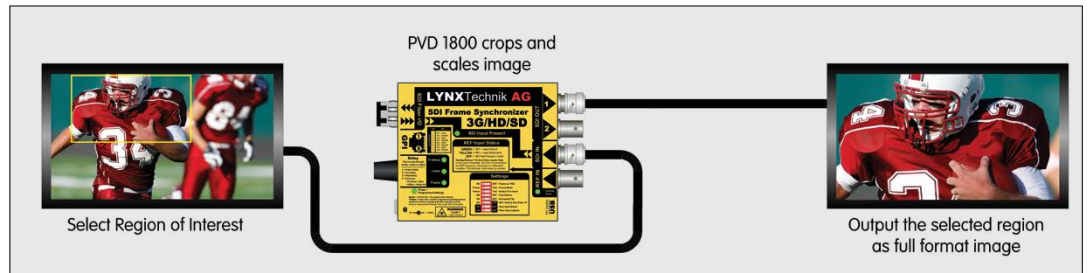

Frame Rate Converter

The converter of the PVD 1800 can perform a simple frame rate conversion by adding or dropping frames.

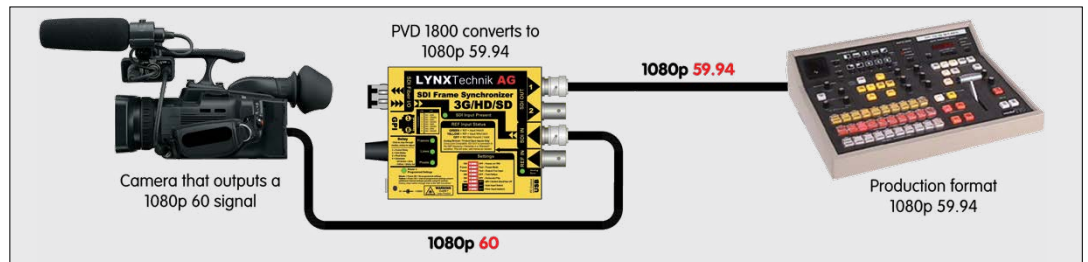

3G Level A ↔ B Dual Link Conversion

The PVD 1800 frame synchronizer is also a 3G Level A and Level B Dual Link converter. This is especially convenient since broadcast equipment is typically only compatible with either Level A or Level B. 3G Level A and Level B Dual Link are not compatible with each other, therefore making the PVD 1800 Frame Synchronizer + Converter an invaluable problem solver.

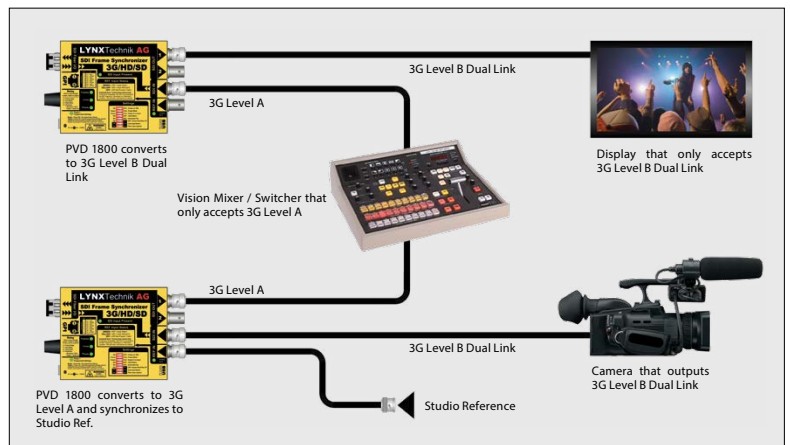

*Distance is an approximation. Actual distances achieved can be longer or shorter depending on the type of cable. Determine link losses and perform optical budget calculations to ensure correct operation.



Visit the
product page:



Features

- Support for 4 independent 12G/6G/3G/1.5G/270M channels
- Transport 8K (uncompressed) signals up to 10km* (6.2miles)
- Each channel supports resolutions up to 2160p/60Hz
- Each channel individually relocked
- Embedded audio / metadata support for each channel
- Integrated expansion port to add more channels
- LED indicators for channel activity and power
- Kit includes transmitter, receiver and power supplies
- Optional 19" Rack tray to mount up to 4 modules

Description

The OTR 1A41 is a self contained fiber transmission kit for the transport of 4 discreet SDI signals (or 8K / 48G uncompressed) over a single fiber link. The kit includes the fiber transmitter, fiber receiver and power supplies. This is an ideal solution for the transmission of multiple uncompressed SDI streams, or 12K signals.

Each SDI channel is fully independent. For 8K use, the signal is split over 4 separate 12G SDI links (48G) and supports full 8K resolution at 60fps. The system can also be used for any combination of SDI signals, with a mix of formats and bit-rates if required. Each channel will automatically detect and relock SDI bit rates of 270Mbit/s, 1.5Gbit/s, 3Gbit/s, 6Gbit/s and 12Gbit/s.

LED Indicators are provided for channel presence and power. An optional 19" rack mount tray is available which can accommodate up to 4 modules (RFR 1018).

Note: Internal WDM optical multiplexing is utilized within the modules. This kit should be considered a self contained point to point solution and should not be integrated into external CWDM systems. An expansion port is included on each module which can be used to add additional SDI channels from the OTR 1A42.

Technical Specifications

SDI Video	4 x SDI inputs on 75 Ohm BNC connections (OTX 1A41) 4 x SDI outputs on 75 Ohm BNC connections (ORX 1A41) SMPTE 259M-2008, SMPTE 292-1:2012, SMPTE 292-2:2011 SMPTE 424M-2006, SMPTE ST-2081, SMPTE ST-2082 Multi-standard / Multi-format operation auto-detect. Multi-rate relocking: 270Mbit/s - 1.5Gbit/s - 3Gbit/s - 12Gbit/s				
	Electrical Return Loss:	to 1.5GHz >15dB	to 3GHz >10dB	to 6GHz >7dB	to 12GHz >4dB
	Automatic Cable EQ*	270Mbit/s 250m	1.5Gbit/s 190m	3Gbit/s 140m	12Gbit/s 80m
		Belden 1694A		Belden 4794R	
Fiber Optics	1 x Fiber optic I/O port (COM port) 1 x Fiber optic expansion port (UPG port) Duplex (singlemode) LC/PC connections SMPTE 297M - 2006 Internal CWDM Multiplexing Wavelengths 1270nm, 1290nm, 1310nm, 1330nm Optical budget 10.6dB Max. Distance* 10km (6.2 miles) Fiber activity LEDs for each channel				
Power	+12V DC 3.7W nominal. (Supports input range 7 - 24 V DC) 2x Power LEDs on side per module				
Physical (per module)	Size (incl. connectors)	170 x 99.7 x 40.5mm (6.7" x 3.9" x 1.6)			
	Weight:	600g (21.1oz)			
Ambient	5 - 40°C (41 - 104°F) 90% Humidity (non condensing)				
Model #	OTR 1A41	EAN# 4250479326637			
Includes	2 Modules, 2 Power Supplies				

*Distance is an approximation. Actual distances achieved can be longer or shorter depending on the type of cable. Determine link losses and perform optical budget calculations to ensure correct operation.

Application Examples

4 x SDI (8K 48G) Fiber Transport

This basic configuration is used for transporting up to 4 discreet SDI signals (SD/HD/3G/6G/12G) or it can be used for transporting a 8K (48G) signal over fiber.

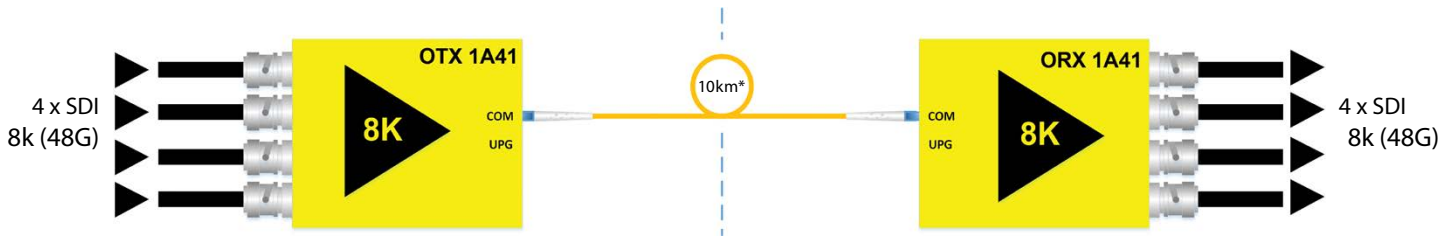

8 x SDI (16K 96G) Fiber Transport

This configuration uses the UPG port to add more channels into the link from the OTR 1A42. This can be used to transport 8 discreet SDI signals (SD/HD/3G/6G/12G) or it can be used for transporting a single 8K (48G) signal over a single fiber.

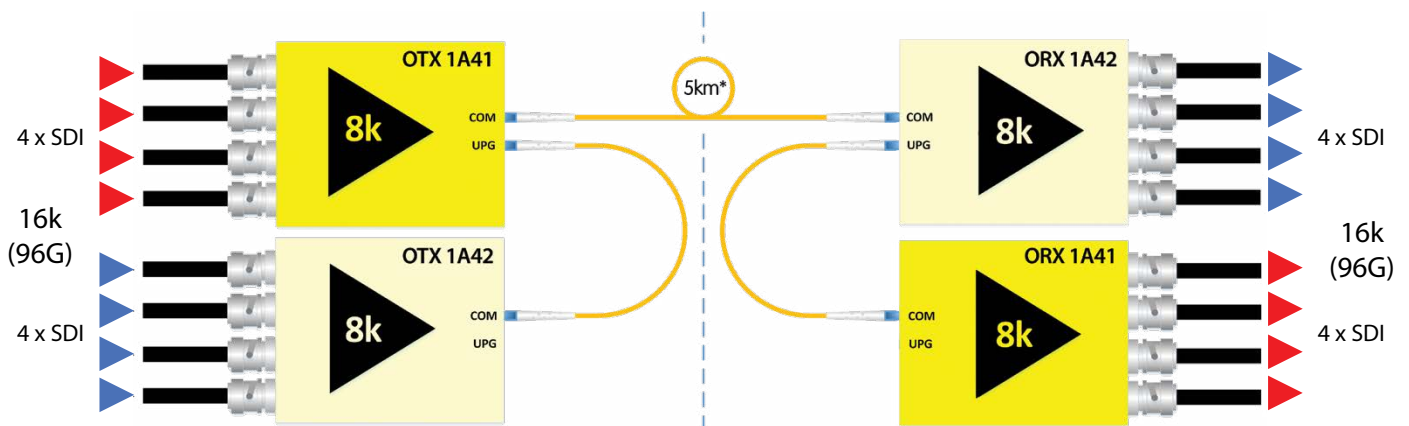

4 x SDI (8K 48G) Bidirectional Fiber Transport

This configuration uses the UPG port to add more channels into the link from the OTR 1A42. This shows a bidirectional application sending and receiving 4 SDI channels, or sending and receiving 8K (48G) over a single fiber.

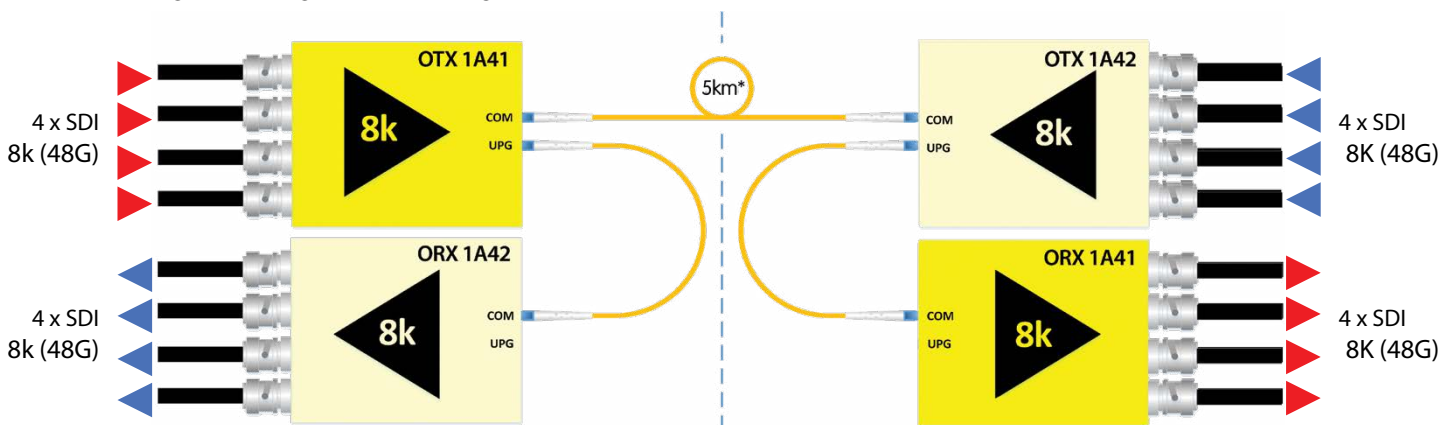

*Distance is an approximation. Actual distances achieved can be longer or shorter depending on the type of cable. Determine link losses and perform optical budget calculations to ensure correct operation.

OTR 1A42**8k Fiber Transmission System**

Visit the
product page:

**Features**

- Support for 4 independent 12G/6G/3G/1.5G/270M channels
- Transport 8k (uncompressed) signals up to 10km* (6.2miles)
- Each channel supports resolutions up to 2160p/60Hz
- Each channel individually relocked
- Embedded audio / metadata support for each channel
- Integrated expansion port to add more channels
- LED indicators for channel activity and power
- Kit includes transmitter, receiver and power supplies
- Optional 19" Rack tray to mount up to 4 modules

Description

The OTR 1A42 is a self contained fiber transmission kit for the transport of 4 discreet 12G SDI signals (or 8k / 48G uncompressed) over a single fiber link. The kit includes the fiber transmitter, fiber receiver and power supplies. This is an ideal solution for the transmission of multiple uncompressed SDI streams up to 12G/4k.

Each SDI channel is fully independent. For 8k use, the signal is split over 4 separate 12G SDI links (48G) and supports full 8k resolution at 60fps. The system can also be used for any combination of SDI signals, with a mix of formats and bit-rates if required. Each channel will automatically detect and relock SDI bit rates of 270Mbit/s, 1.5Gbit/s, 3Gbit/s, 6Gbit/s and 12Gbit/s.

LED Indicators are provided for channel presence and power. An optional 19" rack mount tray is available which can accommodate up to 4 modules (RFR 1018).

Note: Internal WDM optical multiplexing is utilized within the modules. This kit should be considered a self contained point to point solution and should not be integrated into external CWDM systems. An expansion port is included on each module which can be used to add additional SDI channels from the OTR 1A41, bidirectional ethernet or serial RS-232 signal.

Technical Specifications

SDI Video	4 x SDI inputs on 75 Ohm BNC connections (OTX 1A42) 4 x SDI outputs on 75 Ohm BNC connections (ORX 1A42)			
	SMPTE 259M-2008, SMPTE 292-1:2012, SMPTE 292-2:2011 SMPTE 424M-2006, SMPTE ST-2081, SMPTE ST-2082			
	Multi-standard / Multi-format operation auto-detect.			
	Multi-rate relocking: 270Mbit/s - 1.5Gbit/s - 3Gbit/s - 12Gbit/s			
Electrical Return Loss:	to 1.5GHz >15dB	to 3GHz >10dB	to 6GHz >7dB	to 12GHz >4dB
Automatic Cable EQ*	270Mbit/s 250m	1.5Gbit/s, 190m	3Gbit/s, 140m	12Gbit/s 80m
	Belden 1694A		Belden 4794R	
Fiber Optics	1 x Fiber optic I/O port (COM port) 1 x Fiber optic expansion port (UPG port) Duplex (singlemode) LC/PC connections SMPTE 297M - 2006 Internal CWDM Multiplexing			
	Wavelengths 1350nm, 1370nm, 1390nm, 1410nm			
	Optical budget 10.6dB			
	Max. Distance* 10km (6.2 miles)			
	Fiber activity LEDs for each channel			
Power	+12V DC 3.7W nominal. (Supports input range 7 - 24 V DC)			
	2x Power LEDs on side per module			
Physical (per module)	Size 170 x 99.7 x 40.5mm (6.7" x 3.9" x 1.6)			
	Weight: 600g (21.1oz)			
Ambient	5 - 40°C (41 - 104°F) 90% Humidity (non condensing)			
Model #	OTR 1A42 EAN# 4250479328624			
Includes	2 Modules, 2 Power Supplies			

*Distance is an approximation. Actual distances achieved can be longer or shorter depending on the type of cable. Determine link losses and perform optical budget calculations to ensure correct operation.

Application Examples

4 x SDI (8k 48G) Fiber Transport

This basic configuration is used for transporting up to 4 discreet 12G SDI signals (SD/HD/3G/6G/12G) or it can be used for transporting an 8k (48G) signal over fiber.

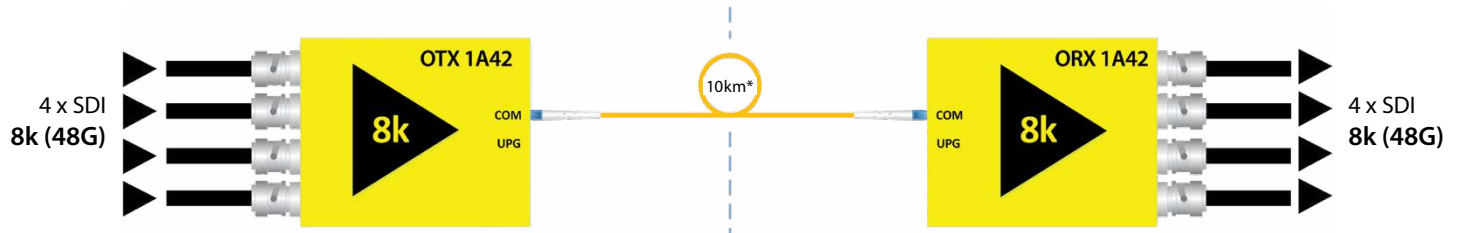

4 x SDI (8k 48G) Fiber Transport + Ethernet

This configuration transports 4 discreet 12G SDI signals (SD/HD/3G/6G/12G) or 8k (48G) and also adds bidirectional Ethernet from the OBD 1510 E into the same fiber link using the UPG expansion port. **Note: Total distance is reduced to 5km when used in this configuration.**

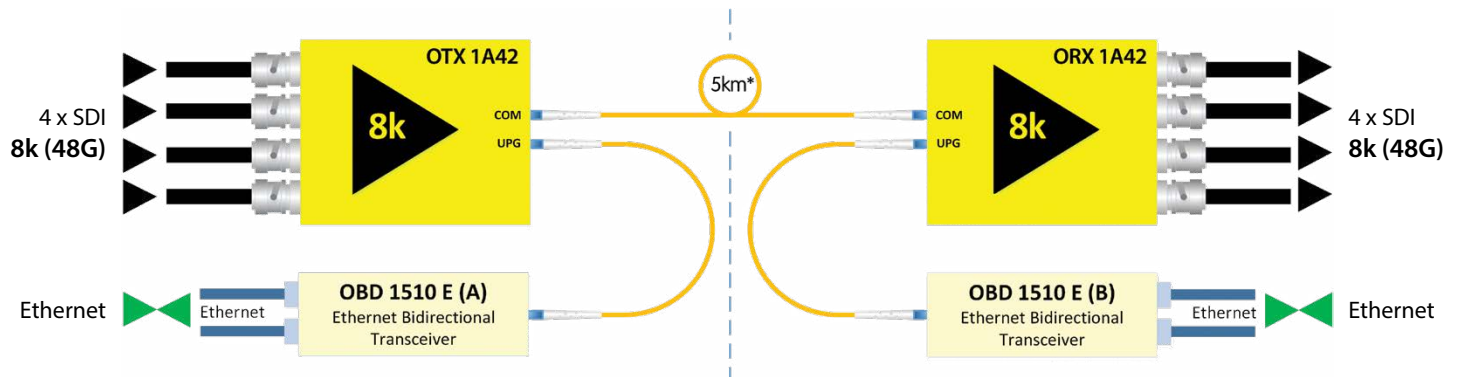

4 x SDI (8k 48G) Fiber Transport + Serial RS 232 + GPI

This configuration transports 4 discreet 12G SDI signals (SD/HD/3G/6G/12G) or 8k (48G) and also adds bidirectional Serial data (RS232/422/485) + GPI from the OBD 1510 D into the same fiber link using the UPG expansion port.

Note: Total distance is reduced to 5km when used in this configuration.

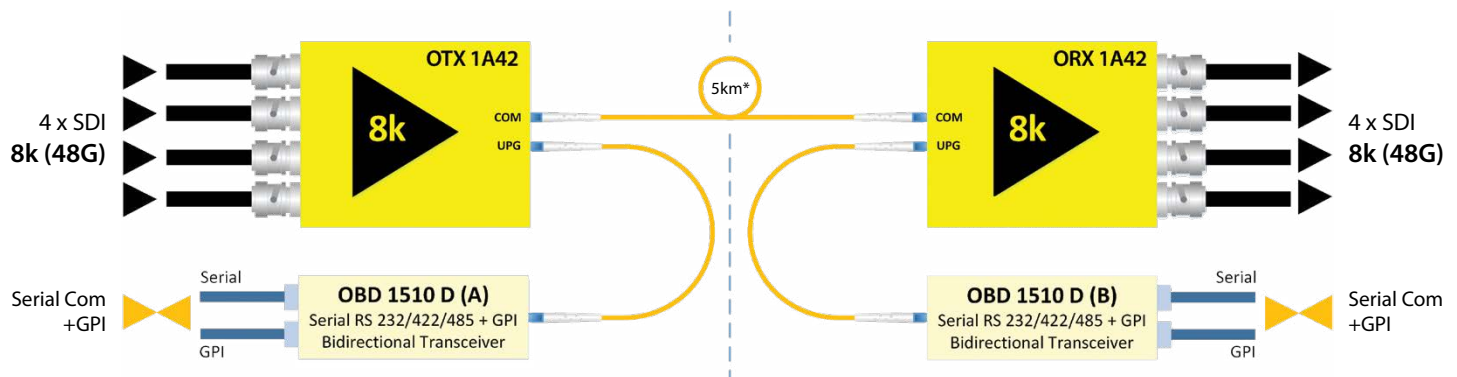

8 x SDI (16k 96G) Uncompressed Fiber Transport and 8k Bidirectional Fiber Transport

Connecting the OTR 1A41 into the expansion port will add 4 more 12G SDI channels to the system which will enable the transport of uncompressed 96Gbit/s over a single fiber link. It is also possible to have 8k (48G) uncompressed bidirectional fiber transport over a single fiber link. Please refer to the product information for the OTR 1A41 for diagrams of these configurations.

*Distance is an approximation. Actual distances achieved can be longer or shorter depending on the type of cable. Determine link losses and perform optical budget calculations to ensure correct operation.

OTR 1441**4k Fiber Transmission System**

Visit the
product page:

**Features**

- Support for 4 independent 3G/HD/SD-SDI channels
- Transport 4K (uncompressed) up to 20km (12 miles)
- Each channel supports resolutions up to 1080p/60Hz
- Each channel individually relocked
- Embedded audio / metadata support for each channel
- Integrated expansion port to add more channels
- LED indicators for channel activity and power
- Kit includes transmitter, receiver and power supplies
- Optional 19" Rack tray to mount (max) 4 modules

Description

The OTR 1441 is a self-contained fiber transmission kit for the transport of 4 discreet SDI signals (or 4K / 12G uncompressed) over a single fiber link. The kit includes the fiber transmitter, fiber receiver, and power supplies. This is an ideal solution for the transmission of multiple uncompressed SDI streams, or 4k up to 20km* with zero losses.

Each SDI channel is fully independent. For 4K use, the signal is split over four separate 3G SDI links (12G) and supports full 4K resolution at 60fps. The system can also be used for any combination of SDI signals, with a mix of formats and bit-rates if required. Each channel will automatically detect and relock SDI bit rates of 270Mbit/s, 1.5Gbit/s, and 3Gbit/s.

An expansion port is included for the connection of the OTR 1441 to add **4 more SDI channels** (or 8k/48G over a single fiber), **bidirectional ethernet** or **serial RS-232 data** into the link.

Note: Internal WDM optical multiplexing is utilized within the modules. This kit should be considered a self contained point to point solution and should not be integrated into external CWDM systems. An expansion port is included on each module which can be used to add additional SDI channels from the OTR 1442.

Technical Specifications

SDI Video	4 x SDI inputs [OTX 1441] on 75 Ohm BNC connections 4 x SDI outputs [ORX 1441] on 75 Ohm BNC connections SMPTE 259M-2008, SMPTE 292-1:2012, SMPTE 292-2:2011 SMPTE 424M-2006, DVB ASI Multi-standard / Multi-format operation auto-detect. Multi-rate relocking: 270Mbit/s - 1.5Gbit/s - 3Gbit/s		
	Electrical Return Loss:	to 1.5GHz >15dB	to 3GHz >10dB
	Automatic Cable EQ*	270Mbit/s 250m	1.5Gbit/s 190m 3Gbit/s 140m
		Belden 1694A	
Fiber Optical	1 x Fiber optic I/O port (COM port) 1 x Fiber optic expansion port (UPG port) - not available in SC variant Duplex (singlemode) LC/PC or SC connections SMPTE 297M - 2006 Internal CWDM Multiplexing Wavelengths: 1270nm, 1290nm, 1310nm, 1330nm Optical budget: 10.6dB Max. distance* 20km (12 miles) Fiber activity LEDs for each channel		
Power	+12V DC nominal. (Supports power from 7 - 24V DC) OTX 1441: 4.1W / ORX 1441: 3.8W 2x Power LEDs on side per module		
Physical (per module)	Size (incl. connectors)	170 x 99.7 x 40.5mm (6.7" x 3.9" x 1.6")	
	Weight:	600g (21.1oz)	
Ambient	5 - 40°C (41 - 104°F) 90% Humidity (non condensing)		
Model #	OTR 1441 LC	EAN# 4250479321151	
	OTR 1441 SC	EAN# 4250479325401	
Includes	2 Modules, 2 Power Supplies		

*Distance is an approximation. Actual distances achieved can be longer or shorter depending on the type of cable. Determine link losses and perform optical budget calculations to ensure correct operation.

Application Examples

4 x SDI (4K 12G) Fiber Transport

This basic configuration is used for transporting up to 4 discreet SDI signals (SD/HD/3G) or it can be used for transporting a 4K (12G) signal over fiber.

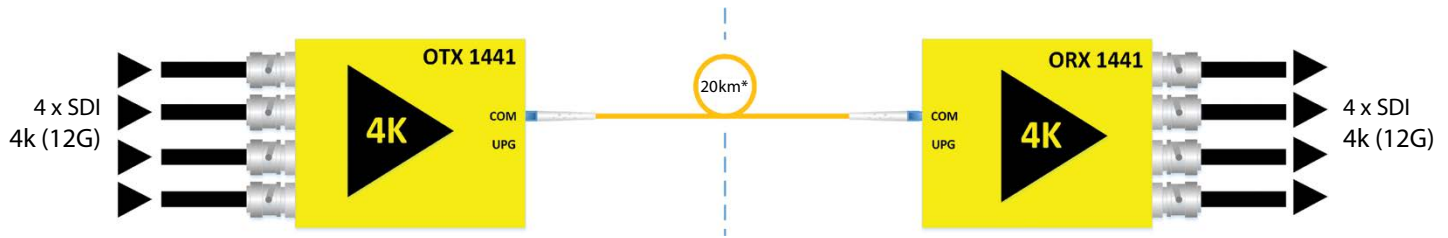

8 x SDI (8K 24G) Fiber Transport

This configuration uses the UPG port to add more channels into the link from the OTR 1442. This can be used to transport 8 discreet SDI signals (SD/HD/3G) or it can be used for transporting a single 8K (24G) signal over a single fiber.

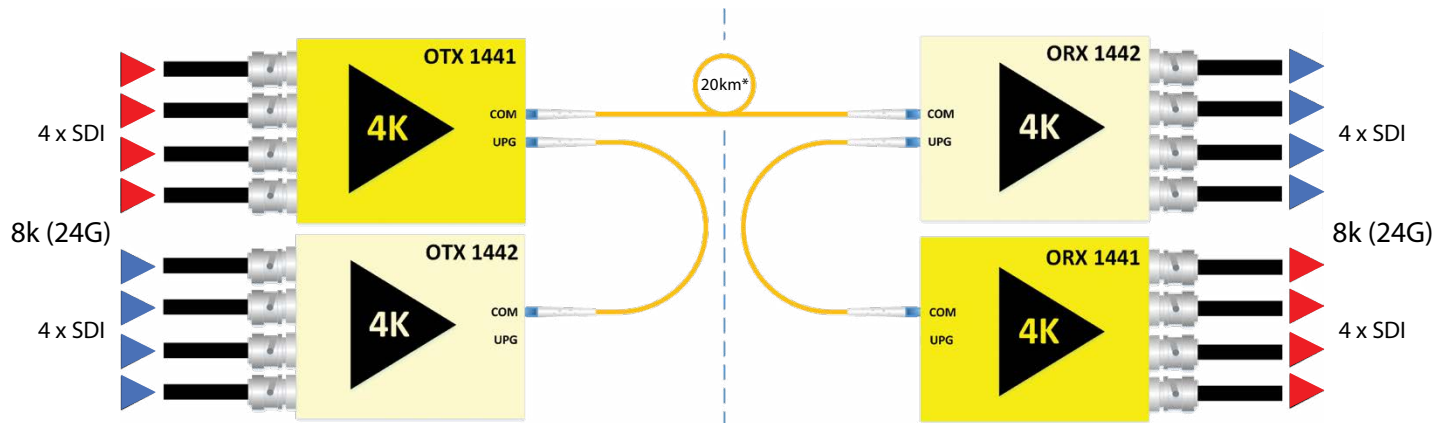

4 x SDI (4K 12G) Bidirectional Fiber Transport

This configuration uses the UPG port to add more channels into the link from the OTR 1442. This shows a bidirectional application sending and receiving 4 SDI channels, or sending and receiving 4K (12G) over a single fiber.

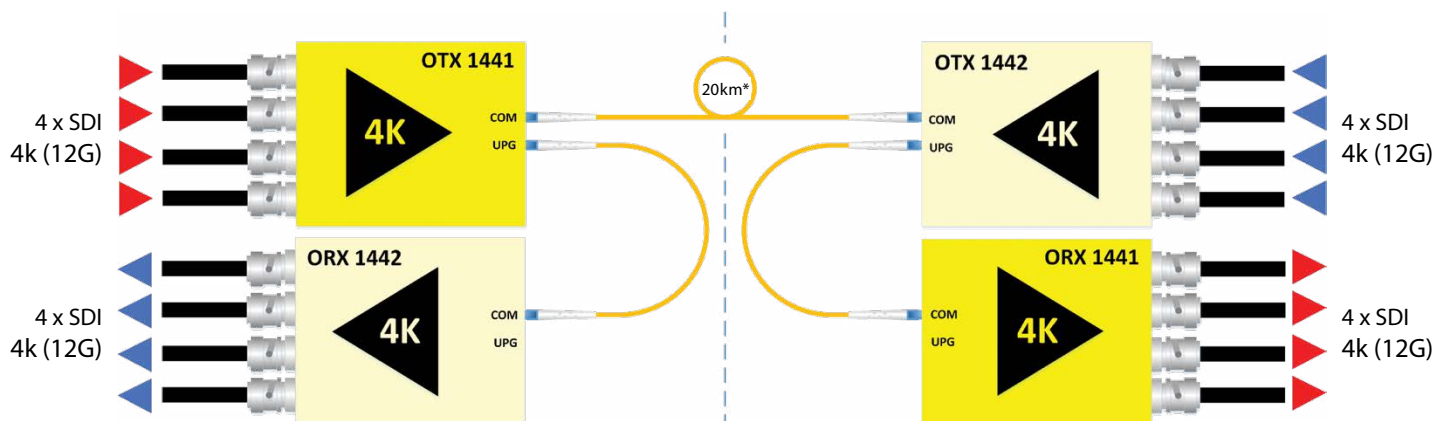

*Distance is an approximation. Actual distances achieved can be longer or shorter depending on the type of cable. Determine link losses and perform optical budget calculations to ensure correct operation.



Visit the
product page:



Features

- Support for 4 independent 3G/HD/SD-SDI channels
- Transport 4K (uncompressed) up to 20km (12 miles)
- Each channel supports resolutions up to 1080p/60Hz
- Each channel individually relocked
- Embedded audio / metadata support for each channel
- Integrated expansion port to add more channels
- LED indicators for channel activity and power
- Kit includes transmitter, receiver and power supplies
- Optional 19" Rack tray to mount (max) 4 modules

Description

The OTR 1442 is a self contained fiber transmission kit for the transport of 4 discreet 3G SDI (or a single, 4K/12G, uncompressed) signals over a single fiber link. The kit includes the fiber transmitter, fiber receiver and power supplies. This is an ideal solution for the transmission of multiple uncompressed SDI streams, or 4K up to 20km* with zero losses.

Each SDI channel is fully independent. For 4K use the signal is split over 4 separate 3G SDI links (12G) and supports full 4K resolution at 60fps. The system can also be used for any combination of SDI signals, with a mix of formats and bit-rates if required. Each channel will automatically detect and relock SDI bit rates of 270Mbit/s, 1.5Gbit/s and 3Gbit/s.

An expansion port is included for the connection of the OTR 1441 to add **4 more SDI channels** (or 8K/48G over a single fiber), **bidirectional ethernet** or **serial RS-232 data** into the link.

LED Indicators are provided for channel presence and power. An optional 19" rack mount tray is available which can accommodate up

Note: Internal WDM optical multiplexing is utilized within the modules. This kit should be considered a self contained point to point solution and should not be integrated into external CWDM systems. An expansion port is included on each module which can be used to add additional SDI channels from the OTR 1441, bidirectional ethernet or serial RS-232 signal.

Technical Specifications

SDI Video	4 x SDI inputs [OTX 1442] on 75 Ohm BNC connections 4 x SDI outputs [ORX 1442] on 75 Ohm BNC connections		
	SMPTE 259M-2008, SMPTE 292-1:2012, SMPTE 292-2:2011 SMPTE 424M-2006, DVB ASI		
	Multi-standard / Multi-format operation auto-detect.		
	Multi-rate relocking: 270Mbit/s - 1.5Gbit/s - 3Gbit/s		
	Electrical Return Loss	to 1.5GHz >15dB	to 3GHz >10dB
	Automatic Cable EQ*	270Mbit/s 250m	1.5Gbit/s 190m 3Gbit/s 140m
		Belden 1694A cable	
Fiber Optics	1 x Fiber optic I/O port (COM port) 1 x Fiber optic expansion port (UPG port) - not available in SC variant Duplex (singlemode) LC/PC or SC/PC connections		
	SMPTE 297M - 2006		
	Internal CWDM Multiplexing		
	Wavelengths	1350nm, 1370nm, 1390nm, 1410nm	
	Optical budget	10.6dB	
	Max. distance*	20km (12 miles)	
	4 Fiber activity LEDs, one for each channel		
Power	+12V DC nominal. ORX 1442 = 3.8W, OTX 1442 = 4.1W Supports external power input from 7 - 24 V DC		
	2x Power LEDs on side per module		
Physical (per module)	Size (incl connectors)	170mm x 99.7mm x 40.5mm (6.7" x 3.9" x 1.6")	
	Weight	600g (21.1oz)	
Ambient	5 - 40°C (41 - 104°F) 90% Humidity (non condensing)		
Model #	OTR 1442 LC	EAN# 4250479324374	
	OTR 1442 SC	EAN# 4250479325418	
Includes	2 Modules, 2 Power Supplies		

*Distance is an approximation. Actual distances achieved can be longer or shorter depending on the type of cable. Determine link losses and perform optical budget calculations to ensure correct operation.

Application Examples

4 x SDI (4K 12G) Fiber Transport

This basic configuration is used for transporting up to 4 discreet SDI signals (SD/HD/3G) or it can be used for transporting a 4K (12G) signal over fiber.

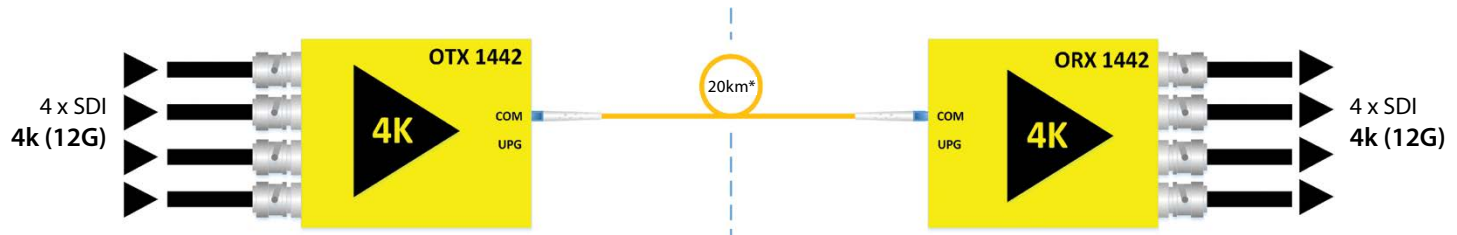

4 x SDI (4K 12G) Fiber Transport + Ethernet

This configuration transports 4 discreet SDI signals (SD/HD/3G) or 4K (12G) and also adds bidirectional Ethernet from the OBD 1510 E into the same fiber link using the UPG expansion port.

Note: Total distance is reduced to 5km when used in this configuration.

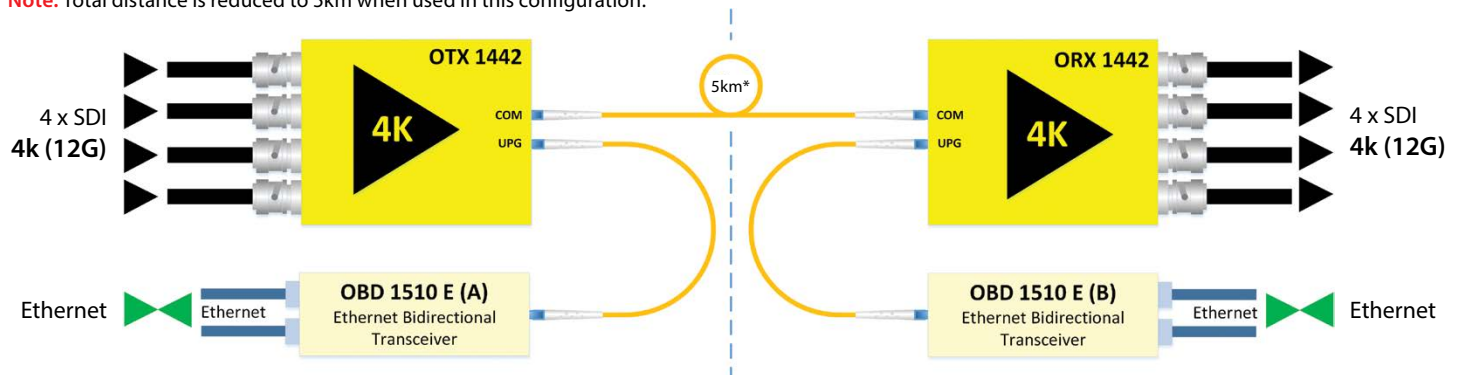

4 x SDI (4K 12G) Fiber Transport + Serial RS 232 + GPI

This configuration transports 4 discreet SDI signals (SD/HD/3G) or 4K (12G) and also adds bidirectional Serial data (RS232/422/485) + GPI from the OBD 1510 D into the same fiber link using the UPG expansion port.

Note: Total distance is reduced to 5km when used in this configuration.

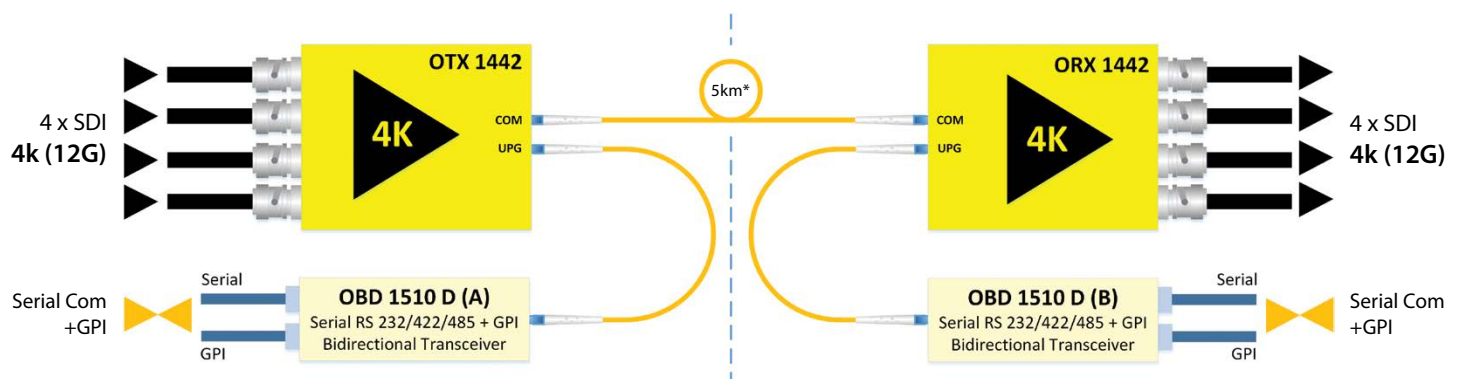

8 x SDI (8K 24G) Fiber Transport and 4K Bidirectional Fiber Transport

Connecting the OTR 1441 into the expansion port will add 4 more SDI channels to the system which will enable the transport of uncompressed 8K (24G) over a single fiber link. It is also possible to have 4K (12G) uncompressed bidirectional fiber transport over a single fiber link. Please refer to the product information for the OTR 1441 for diagrams of these configurations.

*Distance is an approximation. Actual distances achieved can be longer or shorter depending on the type of cable. Determine link losses and perform optical budget calculations to ensure correct operation.

OTR 1410

12G SDI Fiber Optic Transceiver



Features

- SDI fiber receiver and transmitter in single package
- Supports 12G, 6G, 3G, 1.5G and 270M SDI video standards
- 3Gbit/s Level A and Level B (support for all formats)
- Auto relocking 270Mbit/s, 1.5Gbit/s, 3Gbit/s, 6Gbit/s, and 12Gbit/s
- LC/PC duplex connection
- Distance up to 10km* (6.2 miles) @ 12Gbit/s (singlemode)

Description

The OTR 1410 is a Fiber / SDI transmitter and receiver combined in a single self contained package. It is a convenient and cost-effective solution to combat the restrictions involved with the distribution of uncompressed, high bandwidth, broadcast quality video signals over long distances.

Each OTR 1410 transceiver has an independent transmitter and receiver channel, which provides an effective solution for any SDI signal up to 12G (4096x2160 @ 60Hz), while preserving full uncompressed quality.

Operation of the receiver and transmitter is automatic. For transmission, the SDI video format is automatically detected, relocked and then transmitted over the fiber optic TX connection. For reception, the optical SDI video input signal on the RX connection is automatically detected, relocked and provided on the SDI output connection.

The OTR 1410 supports 12G, 6G, 3G, 1.5G, 270M SDI video standards.

Technical Specifications

SDI Video	1 x SDI input on 75 Ohm BNC connectors 1 x SDI output on 75 Ohm BNC connectors	
	SMPTE 2082-1, SMPTE 2081-1, SMPTE 424M, SMPTE 292M, SMPTE 259M	
	Multi-standard operation from 270Mbit/s to 12Gbit/s	
	Multirate relocking: 270Mbit/s - 1.5Gbit/s - 3Gbit/s - 6Gbit/s - 12Gbit/s	
Automatic Cable EQ*	270Mbit/s	1.5Gbit/s 3Gbit/s 6Gbit/s 12Gbit/s
	250m	220m 150m 80m 80m
	Belden 1694A Belden 4794R	
Fiber Optic	1 x fiber optic input, 1 x fiber optic output Duplex (singlemode) using LC/PC connection	
	SMPTE 297M - 2006	
Transmitter	Wavelength	1310nm
	Optical power	-3dBm (typ)
Receiver	Wavelength	1260nm - 1620nm
	Sensitivity	-2dBm to -10dBm
Max. distance*	10km (6.2 miles)	@ 12Gbit/s
	TX & RX active LEDs on side of module	
Power	+12V DC @ 2W nominal - (supports 7 - 24V DC input range)	
	Power LED on side of module	
Physical	Size (incl. connectors)	140mm x 42mm x 22mm (5.51" x 1.65" x 0.86")
	Weight:	125g (4.4oz)
Ambient	5 - 40°C (41 - 104°F) 90% Humidity (non condensing)	
Model #	OTR 1410	4250479324749
Includes	Module, SFP Module, AC power supply	

OBD 1410

12G SDI Bidirectional Fiber Optic Transceiver



Features

- Supports SDI video up to 12G (2160p60)
- 3G Level A and Level B support (all formats)
- Auto relocking 270Mbit/s, 1.5Gbit/s, 3Gbit/s, 6Gbit/s, and 12Gbit/s
- Bidirectional - send and receive on single fiber
- Up to 10km (6.2 miles) @ 12Gbit/s
- Simplex LC/PC singlemode fiber connection

Description

The OBD 1410 is a bidirectional Fiber Optic to SDI transmitter and receiver which uses a single fiber link supplied in a compact self contained package. It is a convenient and cost-effective solution to combat the restrictions involved with the distribution of uncompressed broadcast quality video signals over long distances.

The OBD 1410 modules are supplied in pairs, one Type A and one Type B which work together in a WDM closed loop application. Each module has an electrical SDI in and SDI out connection and uses a single fiber link between the two.

Each channel is fully independent and can have different standards and formats of SDI video. The modules auto-detect and re-clock any 270Mbit/s, 1.5Gbit/s, 3Gbit/s, 6Gbit/s, or 12Gbit/s SDI source prior to conversion. The modules are fully compatible with 3G Level A and Level B formats.

Note: This system used WDM optical multiplexing and should only be used in point to point applications. This solution cannot be integrated into a CWDM multiplexed system.

Technical Specifications

SDI Video	1 x SDI input on 75 Ohm BNC connector 1 x SDI output on 75 Ohm BNC connector			
	SMPTE 2082-1, SMPTE 2081-1, SMPTE 424M, SMPTE 292M, SMPTE 259M			
	Multi-standard operation from 270Mbit/s to 12Gbit/s			
	Multi-rate relocking: 270Mbit/s - 1.5Gbit/s - 3Gbit/s - 6Gbit/s - 12Gbit/s			
Electrical Return Loss:	to 1.5GHz >15dB	to 3GHz >10dB	to 6GHz >7dB	to 12GHz >4dB
Automatic Cable EQ*:	1.5Gbit/s	3Gbit/s	6Gbit/s	12Gbit/s
	220m	150m	90m	80m
	Belden 1694A		Belden 4794R cable	
Fiber Optics	1 x Bidirectional fiber connection (LC/PC Connection)			
	SMPTE 2082, SMPTE 2081, SMPTE 424M, SMPTE 292M, SMPTE 259M			
Wavelength:	Type A	TX: 1270nm / RX: 1330nm (WDM)		
	Type B	TX: 1330nm / RX: 1270nm (WDM)		
Optical power:	Type A / B	-3dBm to +3dBm		
RX Sensitivity	Type A / B	-14dBm @1.5Gbit/s		
		-10dBm @12Gbit/s		
	TX & RX active LED on side of module			
Max. distance*	max. 10km (6.2 miles) @ 3Gbit/s			
Power	+12V DC @ 1.9W nominal - (supports 7 - 24V DC input range)			
	Power LED on side of module			
Physical (per module)	Size (incl. connectors)	140mm x 42mm x 22mm (5.51" x 1.65" x 0.86")		
	Weight	125g (4.4oz)		
Ambient	5 - 40°C (41 - 104°F) 90% Humidity (non condensing)			
Model #	OBD 1410	EAN# 4250479327450		
Includes	2x Modules, 2x SFP Modules, 2x AC power supply			

*Distance is an approximation. Actual distances achieved can be longer or shorter depending on the type of cable. Determine link losses and perform optical budget calculations to ensure correct operation.

OTR 1810-1**3G SDI Fiber Optic Transceiver****Features**

- SDI Fiber receiver and transmitter in single package
- Supports SDI video up to 3Gbit/s (1080p60)
- 3G Level A and Level B support (all formats)
- Auto reclocking 270Mbit/s, 1.5Gbit/s, 3Gbit/s
- Up to 10km* (6.2 miles) @ 3Gbit/s (singlemode)
- Up to 300m* (984 feet) @ 3Gbit/s (multimode)
- Duplex LC optical connection

Description

The OTR 1810-1 is a Fiber/SDI transmitter and receiver combined in a single self contained package. It is a convenient and cost-effective solution to combat the restrictions involved with the distribution of uncompressed broadcast quality video signals over long distances.

Each OTR 1810-1 transceiver has an independent transmitter and receiver channel, which provides

an effective solution for any SDI signal up to 3G (1080p60) while preserving full uncompressed quality.

The OTR 1810-1 will auto-detect and re-clock any 270Mbit/s, 1.5Gbit/s, or 3Gbit/s SDI source prior to conversion. The module is fully compatible with 3G Level A and Level B formats.

Technical Specifications

SDI Video	1 x SDI input on 75 Ohm BNC connectors 1 x SDI output on 75 Ohm BNC connectors		
	SMPTE 424M, SMPTE 292M, SMPTE 259M, DVB-ASI		
	Multi-standard operation from 270Mbit/s to 3Gbit/s		
	Multi-rate reclocking 270Mbit/s - 1.5Gbit/s - 3Gbit/s		
Electrical Return Loss:	to 1.5GHz >15dB	to 3GHz: >10dB	
Automatic Cable EQ*:	270Mbit/s	1.5Gbit/s	3Gbit/s
	250m	220m	150m
	Belden 1694A cable		
Fiber Optic	1 x fiber optic input, 1 x fiber optic output Duplex (Singlemode) using LC/PC Connections		
	SMPTE 297M - 2006		
Singlemode OTR 1810-1 LC	Transmitter	Wavelength:	1310nm
		Optical Power:	-5 dBm (typ.)
	Receiver	Wavelength:	1260nm to 1620nm
		Sensitivity:	-16 dBm (min.)
Max. distance*	10km (6.2 miles) @3Gbit/s		
Multimode OTR 1810-1	Transmitter	Wavelength:	850nm
		Optical Power:	-7dBm to -2dBm
	Receiver	Wavelength:	750nm to 880nm
		Sensitivity:	-15 dBm (min)
Max. distance*	300m (984 feet) @3Gbit/s		
	TX & RX active LEDs on side of module		
Power	+12V DC @ 2W nominal with SFP - (supports 7 - 24V DC input range) Power LED on side of module		
Physical	Size (incl. connectors) 140mm x 42mm x 22mm (5.51" x 1.65" x 0.86") Weight: 125g (4.4oz)		
Ambient	5 - 40°C (41 - 104°F) 90% Humidity (non condensing)		
Model #	OTR 1810-1 LC	EAN# 4250479318144	
	OTR 1810-1 MM	EAN# 4250479359840	
Includes	Module, SFP Module, AC power supply		

*Distance is an approximation. Actual distances achieved can be longer or shorter depending on the type of cable. Determine link losses and perform optical budget calculations to ensure correct operation.

OBD 1810-2**3G SDI Bidirectional Fiber Optic Transceiver****Features**

- Supports SDI video up to 3G (1080p60)
- 3G Level A and Level B support (all formats)
- Auto reclocking 270Mbit/s, 1.5Gbit/s, and 3Gbit/s
- Bidirectional - send and receive on single fiber
- Up to 10km* (6.2 miles) @ 3Gbit/s
- Simplex LC/PC singlemode fiber connection

Description

The OBD 1810-2 is a bidirectional Fiber Optic to SDI transmitter and receiver which uses a single fiber link supplied in a compact self contained package. It is a convenient and cost-effective solution to combat the restrictions involved with the distribution of uncompressed broadcast quality video signals over long distances.

The OBD 1810-2 modules are supplied in pairs, one Type A and one Type B which work together in a WDM closed loop application. Each module has an electrical SDI in and SDI out connection and uses a single fiber link between the two.

Each channel is fully independent and can have

different standards and formats of SDI video. The modules auto-detect and re-clock any 270Mbit/s, 1.5Gbit/s and 3Gbit/s SDI source prior to conversion. The modules are fully compatible with 3G Level A and B formats.

Note: This system used WDM optical multiplexing and should only be used in point to point applications. This solution cannot be integrated into a CWDM multiplexed system.

Technical Specifications

SDI Video	1 x SDI input on 75 Ohm BNC connector 1 x SDI output on 75 Ohm BNC connector		
	SMPTE 424M, SMPTE 292M, SMPTE 259M, DVB-ASI		
	Multi-standard operation from 270Mbit/s to 3Gbit/s		
	Multi-rate reclocking: 270Mbit/s - 1.5Gbit/s - 3Gbit/s		
Electrical Return Loss:	to 1.5GHz: >15dB	to 3GHz: >10dB	
Automatic Cable EQ*:	270Mbit/s	1.5Gbit/s	3Gbit/s
	250m	220m	150m
	Belden 1694A		
Fiber Optics	1 x Bidirectional fiber connection (LC/PC Connection) SMPTE 297M		
Wavelength:	Type A	TX: 1310nm / RX: 1550nm (WDM)	
	Type B	TX: 1550nm / RX: 1310nm (WDM)	
Optical power:	Type A / B	-8dBm to -3dBm	
RX Sensitivity	Type A / B	-16dBm @3Gbit/s	
TX active LED on side of module			
Max. distance*	max. 10km (6.2 miles) @3Gbit/s		
Power	+12V DC @ 1.9W nominal - (supports 7 - 24V DC input range) Power LED on side of module		
Physical (per module)	Size 140mm x 42mm x 22mm (5.51" x 1.65" x 0.86") Weight 125g (4.4oz)		
Ambient	5 - 40°C (41 - 104°F) 90% Humidity (non condensing)		
Model #	OBD 1810-2	EAN# 4250479318175	
Includes	2x Modules, 2x SFP Modules, 2x AC power supply		

OTR 1440

12G SDI Fiber Optic Transceiver [CWDM]



Installed optional SFP shown is not included



Features

- Optical receiver and transmitter in single package
- Supports SDI video up to 12Gbit/s (4096x2160 @ 60 Hz)
- 3G Level A and Level B support (all formats)
- Auto relocking 1.5Gbit/s, 3Gbit/s, 6Gbit/s, 12Gbit/s
- CWDM with 18 wavelengths (1270nm to 1610nm) selections
- Up to 10km* (6.2 miles) @ 12Gbit/s (singlemode)
- Duplex LC/PC single mode optical connections

Description

The OTR 1440 is a CWDM fiber optic to SDI transmitter and receiver combined in a compact self contained package. It is a convenient and cost-effective solution to combat the restrictions involved with the distribution of uncompressed broadcast quality video signals over long distances.

Each OTR 1440 CWDM transceiver has an independent transmitter and receiver channel, which provides an effective solution for any SDI signal up to 12G (4096x2160 @ 60Hz), while preserving

full uncompressed quality. Select from 18 transmitter wavelengths for full CWDM compatibility (ITU-T G.694.2)

The OTR 1440 will auto-detect and re-clock any 270Mbit/s, 1.5Gbit/s, 3Gbit/s, 6Gbit/s, or 12Gbit/s SDI source prior to conversion. The module is fully compatible with 3G Level A and Level B formats.

Note: This yellobrik **DOES NOT INCLUDE** the fiber SFP module. Please specify the required SFP option from the option list.

Technical Specifications

SDI Video	1 x SDI input on 75 Ohm BNC connectors 1 x SDI output on 75 Ohm BNC connectors SMPTE 2082-1, SMPTE 2081-1, SMPTE 424M, SMPTE 292M, SMPTE 259M Multi-standard operation from 270Mbit/s to 12Gbit/s Multirate relocking: 270Mbit/s - 1.5Gbit/s - 3Gbit/s - 6Gbit/s - 12Gbit/s				
Electrical Loss	Return Loss	to 1.5GHz	to 3GHz	to 6GHz	to 12GHz
		>15dB	>10dB	>7dB	>4dB
Automatic Cable EQ*	270Mbit/s	1.5Gbit/s	3Gbit/s	6Gbit/s	12Gbit/s
	250m	220m	150m	90m	80m
	Belden 1694A			Belden 4794R	
Fiber Optic	1 x fiber optic input, 1 x fiber optic output Duplex (singlemode) using LC/PC connection SMPTE 297M - 2006				
Transmitter	Wavelength	Optical power			See CWDM Wavelength Options
Receiver	Sensitivity				
Max. distance*	10km (6.2 miles) @ 12Gbit/s				
Power	+12V DC @ 1.9W nominal - (supports 7 - 24V DC input range) Power LED on side of module				
Physical	Size	140mm x 42mm x 22mm (incl. connectors) (5.51" x 1.65" x 0.86")			
	Weight:	125g (4.4oz)			
Ambient	5 - 40°C (41 - 104°F) 90% Humidity (non condensing)				
Model #	OTR 1440	4250479326620			
Includes	Module, AC power supply				

SFP Module Options

Base price **DOES NOT INCLUDE** the fiber transmitter SFP. Please specify the required SFP from the option list.

Option #	Wavelength (20nm increments)	TX/RX	Max. Transmission	Max. Distance
OH-TR-12G-XXXX-LC	1270 - 1610 nm	TX: -2...+3dBm / RX: -10dBm	12Gbit/s	10km*
OH-TR-1-XXXX-LC	1270 - 1610 nm	TX: -4...+2dBm / RX: -16dBm	3Gbit/s	10km*
OH-TR-4-XXXX-LC	1270 - 1610 nm	TX: -4...+2dBm / RX: -20dBm	3Gbit/s	40km*
OH-TR-8-XXXX-LC	1270 - 1610 nm	TX: +1...+5dBm / RX: -28dBm	3Gbit/s	80km*

*Distance is an approximation. Actual distances achieved can be longer or shorter depending on the type of cable. Determine link losses and perform optical budget calculations to ensure correct operation.

OTR 1840-1

3G SDI Fiber Optic Transceiver [CWDM]



Installed optional SFP shown is not included



Features

- Optical receiver and transmitter in single package
- Supports SDI video up to 3G (1080p60)
- 3G Level A and Level B support (all formats)
- Auto relocking 270Mbit/s, 1.5Gbit/s, 3Gbit/s
- CWDM with 18 wavelength selections
- Up to 40km* (24.8 miles) @ 3Gbit/s
- Duplex LC/PC singlemode optical connections

Description

The OTR 1840-1 is a CWDM Fiber Optic to SDI transmitter and receiver combined in a compact self contained package. It is a convenient and cost-effective solution to combat the restrictions involved with the distribution of uncompressed broadcast quality video signals over long distances.

Each OTR 1840-1 CWDM transceiver has an independent transmitter and receiver channel, which provides an effective solution for any SDI signal up to 3G (1080p60) while preserving full

uncompressed quality. Select from 18 transmitter wavelengths for full CWDM compatibility (ITU-T G.694.2)

The OTR 1840-1 will auto-detect and re-clock any 270Mbit/s, 1.5Gbit/s, and 3Gbit/s SDI source prior to conversion. The module is fully compatible with 3G Level A and Level B formats.

Note: This yellobrik **DOES NOT INCLUDE** the fiber SFP module. Please specify the required SFP option from the option list.

Technical Specifications

SDI Video	1 x SDI input on 75 Ohm BNC connectors 1 x SDI output on 75 Ohm BNC connectors SMPTE 424M, SMPTE 292M, SMPTE 259M, DVB-ASI Multi-standard operation from 270Mbit/s to 3Gbit/s Multi-rate relocking: 270Mbit/s - 1.5Gbit/s - 3Gbit/s		
Electrical Return Loss:	to 1.5GHz	>15dB	to 3GHz: >10dB
Automatic Cable EQ*:	270Mbit/s	1.5Gbit/s	3Gbit/s
	250m	220m	150m
	Belden 1694A cable		
Fiber Optic	1 x fiber optic input, 1 x fiber optic output Duplex (Singlemode) using LC/PC Connections SMPTE 297M - 2006		
Transmitter	Wavelength:	Optical Power: See CWDM Wavelength Options	
Receiver	Sensitivity:		
Max. distance*	40km(24.8miles) @3Gbit/s		
Power	+12V DC @ 2.0W nominal with SFP - (supports 7 - 24V DC input range) Power LED on side of module		
Physical	Size	140mm x 42mm x 22mm (incl. connectors) (5.51" x 1.65" x 0.86")	
	Weight:	125g (4.4oz)	
Ambient	5 - 40°C (41 - 104°F) 90% Humidity (non condensing)		
Model #	OTR 1840-1	EAN# 4250479318403	
Includes	Module, AC power supply		

OTX 1410

12G SDI to Fiber Optic Transmitters



OTX 1410 LC Version Shown



Features

- Supports 12G, 6G, 3G, 1.5G and 270M SDI video inputs
- 3G Level A and Level B (support for all formats)
- Auto reclocking 270M, 1.5Gbit/s, 3Gbit/s, 6Gbit, and 12Gbit/s
- Reclocked SDI loop out connection
- LC and ST connection variants
- Up to 10km* (6.2 miles) @ 12Gbit/s with OTX 1410 LC and ST variant
- Up to 40km* (24.8 miles) @ 12Gbit/s with OTX 1410 LC-40 variant

Description

The OTX 1410 is a compact SDI to fiber optic transmitter designed to combat the restrictions involved with the distribution of uncompressed, high bandwidth, broadcast-quality video signals over long distances.

When paired with the fiber optic to SDI receiver (e.g. yellobrik ORX 1400) you have a very cost-effective optical transmitter/receiver system for

signals up to 12G (4096x2160 @ 60Hz) while preserving full, uncompressed quality.

The OTX 1410 supports 12G, 6G, 3G, 1.5G and 270M SDI video standards and is available in LC, LC-40, and ST variants.

Technical Specifications

SDI Video	1x SDI input on 75 Ohm BNC connector			
	1x SDI output reclocked loop on 75 Ohm BNC connector			
	SMPTE 2082-1, SMPTE 2081-1, SMPTE 424M, SMPTE 292M			
	Multi-standard operation from 270Mbit/s to 12Gbit/s			
Multi-rate reclocking: 1.5Gbit/s to 12Gbit/s				
Electrical Return Loss:	to 1.5GHz	to 3GHz	to 6GHz	to 12GHz
	>15dB	>10dB	>7dB	>4dB
Automatic Cable EQ*:	1.5Gbit/s	3Gbit/s	6Gbit/s	12Gbit/s
	220m	150m	90m	80m
		Belden 1694A cable		Belden 4794R cable
Optical Output	1 x fiber optic output - Simplex (singlemode) using LC/PC Connection			
	SMPTE 297M - 2006			
	Wavelength:	1310nm		
	Optical power:	-3dBm (typ.)		
TX active LED on side of module				
Max. distance*	OTX 1410 LC/ST	max. 10km @ 12Gbit/s		
	OTX 1410 LC-40	max. 40km @ 12Gbit/s		
Power	+12V DC @ 2.0W nominal - (supports 7 - 24V DC input range)			
	Power LED on side of module			
Physical	Size	140mm x 42mm x 22mm		
	(incl.connectors)	(5.51" x 1.65" x 0.86")		
	Weight	125g (4.4oz)		
Ambient	5 - 40°C (41 - 104°F) 90% Humidity (non condensing)			
Model #	OTX 1410 LC	EAN# 4250479324756		
	OTX 1410 LC-40	EAN# 4250479328495		
	OTX 1410 ST	EAN# 4250479327641		
Includes	Module, SPF module, AC power supply			

OTT 1412

Dual 12G SDI to Fiber Optic Transmitters



Features

- Dual channel
- Supports 12G, 6G, 3G, 1.5G, and 270M SDI video inputs
- 3G Level A and Level B support (all formats)
- Auto reclocking 270M, 1.5G, 3G, 6G, and 12G
- Up to 10km* (6.2 miles) @ 12Gbit/s (singlemode)
- Duplex LC/PC singlemode optical connection

Description

The OTT 1412 is a compact, dual-channel SDI to fiber optic transmitter designed to combat the restrictions involved with the distribution of uncompressed broadcast quality video signals over long distances.

When paired with e.g. yellobrik ORR 1402 you have a very cost-effective dual channel optical transmitter/receiver system for signals up to 12G

(4096x2160 @ 60Hz) while preserving full uncompressed quality.

It has two independent channels, each will auto-detect and re-clock any 270Mbit/s, 1.5Gbit/s, 3Gbit/s, 6Gbit/s, or 12Gbit/s SDI source before optical transmission. The module is fully compatible with 3G Level A and Level B formats.

Technical Specifications

SDI Input	2 x SDI video on 75 Ohm BNC connector			
	(two independent channels)			
	SMPTE 2082-1, SMPTE 2081-1, SMPTE 424M, SMPTE 292M, SMPTE 259M			
	Multi-standard operation from 270Mbit/s to 12Gbit/s			
Multi-rate reclocking: 270Mbit/s to 12Gbit/s				
Electrical Return Loss:	to 1.5GHz	to 3GHz	to 6GHz	to 12GHz
	>15dB	>10dB	>7dB	>4dB
Automatic Cable EQ*:	1.5Gbit/s	3Gbit/s	6Gbit/s	12Gbit/s
	190m	140m	90m	80m
		Belden 1694A cable		Belden 4794R cable
Optical Output	2 x fiber optic outputs - Duplex (singlemode) using LC/PC Connections			
	SMPTE 297M - 2006			
	Wavelength:	1310nm (each channel)		
	Optical power:	-5.5dBm...0.5dBm (each channel)		
2x TX active LED on side of module				
Max. distance*	max. 10km (6.2 miles)	@ 12Gbit/s		
Power	+12V DC @ 2.5W nominal - (supports 7 - 24V DC input range)			
Power LED on side of module				
Physical	Size	140mm x 42mm x 22mm		
	(incl.connectors)	(5.51" x 1.65" x 0.86")		
	Weight	125g (4.4oz)		
Ambient	5 - 40°C (41 - 104°F) 90% Humidity (non condensing)			
Model #	OTT 1412	EAN# 4250479326491		
Includes	Module, SFP Module, AC power supply			

*Distance is an approximation. Actual distances achieved can be longer or shorter depending on the type of cable. Determine link losses and perform optical budget calculations to ensure correct operation.

OTX 1440

12G SDI to Fiber Optic Transmitters [CWDM]



SFP shown is not included



Features

- Supports 12G, 6G, 3G and 1.5G SDI video inputs
- 3G Level A and Level B support (all formats)
- Auto reclocking 270Mbit/s, 1.5Gbit/s, 3Gbit/s, 6Gbit/s, and 12Gbit/s
- Reclocked SDI loop output
- Multiple wavelengths available
- Error free optical transmission

Description

The OTX 1440 is a compact CWDM SDI to fiber optic transmitter designed to combat the restrictions involved with the distribution of uncompressed broadcast quality video signals over long distances.

compressed quality.

Operation of the OTX 1440 is fully automatic. The SDI video format is detected, reclocked and then transmitted over the fiber optic connection. A reclocked electrical SDI output is also provided.

Note: This yellowlobrik **DOES NOT INCLUDE** the fiber SFP module. Please specify the required SFP option from the option list.

When paired with another yellowlobrik (e.g. yellowlobrik ORX 1400) you have a very cost-effective optical transmission/receiver system for signals up to 12G (4096x2160 @ 60Hz) while preserving full un-

Technical Specifications

SDI Video	1x SDI input on 75 Ohm BNC connector 1x SDI output reclocked loop on 75 Ohm BNC connector SMPTE 2082-1, SMPTE 2081-1, SMPTE 424M, SMPTE 292M Multi-standard operation from 270Mbit/s to 12Gbit/s Multi-rate reclocking: 1.5Gbit/s to 12bit/s			
Electrical Return Loss:	to 1.5GHz >15dB	to 3GHz >10dB	to 6GHz >7dB	to 12GHz >4dB
Automatic Cable EQ*:	1.5Gbit/s 220m	3Gbit/s 150m	6Gbit/s 90m	12Gbit/s 80m
	Belden 1694A cable		Belden 4794R cable	
Optical Output	1 x fiber optic output - Simplex (singlemode) using LC/PC Connection SMPTE 297M - 2006 Wavelength: CWDM selection. See select SFP table Optical power: see selected SFP option TX active LED on side of module			
Max. distance*	OH-TX-12G-XXXX-LC	max. 10km @ 12Gbit/s		
	OH-TX-4-XXXX-LC	max. 40km @ 3Gbit/s		
	OH-TX-8-XXXX-LC	max 80km @ 3Gbit/s		
Power	+12V DC @ 2.0W nominal - (supports 7 - 24V DC input range) Power LED on side of module			
Physical	Size 140mm x 42mm x 22mm (incl.connectors) (5.51" x 1.65" x 0.86") Weight 125g (4.4oz)			
Ambient	5 - 40°C (41 - 104°F) 90% Humidity (non condensing)			
Model #	OTX 1440 EAN# 4250479325968			
Includes	Module, AC power supply			

SFP Module Options

Option #	Wavelength (20nm increments)	TX Power	Max. Transmission	Max. Distance
OH-TX-12G-XXXX-LC	1270 - 1610 nm	-2...+3dBm	12Gbit/s	10km*
OH-TX-4-XXXX-LC	1270 - 1610 nm	-4...+2dBm	3Gbit/s	10km*
OH-TX-8-XXXX-LC	1270 - 1610 nm	+1...+5dBm	3Gbit/s	40km*

*Distance is an approximation. Actual distances achieved can be longer or shorter depending on the type of cable. Determine link losses and perform optical budget calculations to ensure correct operation.

OTT 1442

Dual 12G SDI to Fiber Optic Transmitters [CWDM]



SFP shown is not included



Features

- Dual Channel
- Supports SDI video inputs up to 12G (2160p60)
- 3G Level A and Level B support (all formats)
- Auto reclocking 270M, 1.5G, 3G, 6G, and 12G
- Distance up to 10km* (6.2 miles) @ 12Gbit/s
- Duplex LC/PC single mode optical connections

Description

The OTT 1442 is a compact CWDM dual channel SDI to fiber optic transmitter designed to combat the restrictions involved with the distribution of uncompressed broadcast quality video signals over long distances. Nine pairs of wavelength choices are provided.

uncompressed quality.

When paired with e.g yellowlobrik ORR 1402 you have a very cost-effective optical transmitter/receiver system for two independent signals up to 12G (4096x2160 @ 60Hz) while preserving full

It has two independent channels, each will auto-detect and re-clock any 270Mbit/s, 1.5Gbit/s, 3Gbit/s, and 12Gbit/s SDI source before optical transmission. The module is fully compatible with 3G Level A/B formats.

Note: This yellowlobrik **DOES NOT INCLUDE** the fiber SFP module. Please specify the required SFP option from the option list.

Technical Specifications

SDI Input	2 x SDI video on 75 Ohm BNC connector (two independent channels) SMPTE 2082-1, SMPTE 2081-1, SMPTE 424M, SMPTE 292M, SMPTE 259M, DVB-ASI Multi-standard operation from 270Mbit/s to 12Gbit/s Multi-rate reclocking: 270Mbit/s to 12Gbit/s			
Electrical Return Loss:	to 1.5GHz >15dB	to 3GHz >10dB	to 6GHz >7dB	to 12GHz >4dB
Automatic Cable EQ*:	1.5Gbit/s 190m	3Gbit/s 140m	6Gbit/s 90m	12Gbit/s 80m
	Belden 1694A cable		Belden 4794R cable	
Optical Output	2 x fiber optic outputs - Duplex (singlemode) using LC/PC Connections SMPTE 297M - 2006 Wavelength: CWDM selection. See select SFP table Optical power: see selected SFP option 2x TX active LED on side of module			
Max. distance*	~10km (6.2 miles) @ 12Gbit/s			
Power	+12V DC @ 2.4W nominal - (supports 7 - 24V DC input range) Power LED on side of module			
Physical	Size 140mm x 42mm x 22mm (incl.connectors) (5.51" x 1.65" x 0.86") Weight 125g (4.4oz)			
Ambient	5 - 40°C (41 - 104°F) 90% Humidity (non condensing)			
Model #	OTT 1442 EAN# 4250479327238			
Includes	Module, AC power supply			

SFP Module Options

Option #	Wavelength (20nm increments)	TT Power	Max. Transmission	Max. Distance
OH-TT-12G-XXXX-LC	1270 - 1610 nm	-2...+3dBm	12Gbit/s	10km*
OH-TT-4-XXXX-LC	1270 - 1610 nm	-4...+2dBm	3Gbit/s	10km*
OH-TT-8-XXXX-LC	1270 - 1610 nm	+1...+5dBm	3Gbit/s	40km*

OTX 1812**3G SDI to Fiber Optic Transmitters**

OTX 1812 LC Version Shown

**Features**

- Supports SDI video inputs up to 3G (1080p60)
- 3G Level A and Level B support (all formats)
- Auto relocking 270Mbit/s, 1.5Gbit/s, and 3Gbit/s
- Relocked SDI loop out connection
- Versions for LC, ST or SC fiber connections
- Up to 10km* (6.2 miles) @ 3Gbit/s (singlemode)
- Up to 300m* (984 feet) @ 3Gbit/s (multimode)

Description

The OTX 1812 is a compact SDI to fiber optic transmitter designed to combat the restrictions involved with the distribution of uncompressed broadcast quality video signals over long distances.

When paired with the fiber optic to SDI receiver (e.g. ORX 1802) you have a very cost-effective optical transmission / receiver system for signals up to 3G (1080p60) while preserving full uncompressed quality.

The OTX 1812 provides a looping SDI input and support for LC, ST or SC singlemode fiber connections as well as an LC version suitable for multimode fiber.

The module will auto-detect and re-clock any 270Mbit/s, 1.5Gbit/s, and 3Gbit/s SDI source prior to optical transmission. The module is fully compatible with 3G Level A and Level B formats.

Technical Specifications

SDI Video	1x SDI input on 75 Ohm BNC connector		
	1x SDI output relocked loop on 75 Ohm BNC connector		
	SMPTE 424M, SMPTE 292M, SMPTE 259M, DVB-ASI		
	Multi-standard operation from 270Mbit/s to 3Gbit/s		
	Multi-rate relocking: 270Mbit/s - 1.5Gbit/s - 3Gbit/s		
Electrical Return Loss:		to 1.5GHz: >15dB	to 3GHz: >10dB
Automatic Cable EQ*:	270Mbit/s	1.5Gbit/s	3Gbit/s
	250m	220m	150m
	Belden 1694A cable		

Optical Output	1 x fiber optic output	
	Simplex (singlemode) LC/PC, ST/PC, or SC/PC connection or Simplex (multimode) LC/PC connection	
	SMPTE 297M - 2006	
Wavelength:	OTX 1812 LC /ST/SC	1310nm
	OTX 1812 MM	850nm
Optical power:	OTX 1812 LC/ST/SC	-8 dBm to -3dBm
	OTX 1812 MM	-7dBm to -2dBm
	TX active LED on side of module	
Max. distance*	OTX 1812 LC/ST/SC	max. 10km* (6.2 miles) @ 3Gbit/s
	OTX 1812 MM	max. 300m* (984 feet) @ 3Gbit/s

Power	+12V DC @ 1.9W nominal - (supports 7 - 24V DC input range)	
	Power LED on side of module	

Physical	Size	140mm x 42mm x 22mm (incl.connectors) (5.51" x 1.65" x 0.86")
	Weight	125g (4.4oz)

Ambient	5 - 40°C (41 - 104°F) 90% Humidity (non condensing)	
----------------	---	--

Model #	OTX 1812 LC	EAN# 4250479359642
	OTX 1812 ST	EAN# 4250479359666
	OTX 1812 SC	EAN# 4250479359659
	OTX 1812 MM	EAN# 4250479359673

Includes	Module, SFP Module, AC power supply	
-----------------	-------------------------------------	--

OTT 1812-1**Dual 3G SDI to Fiber Optic Transmitters****Features**

- Dual channel
- Supports SDI video inputs up to 3G (1080p60)
- 3G Level A and Level B support (all formats)
- Auto relocking 270M, 1.5G, and 3G
- Up to 10km* (6.2 miles) @ 3Gbit/s
- Duplex LC/PC singlemode optical connection

Description

The OTT 1812-1 is a compact dual channel SDI to fiber optic transmitter designed to combat the restrictions involved with the distribution of uncompressed broadcast quality video signals over long distances.

When paired with the dual-channel fiber optic to SDI receiver (e.g. yellobrik ORR 1802-2) you have a very cost-effective dual channel optical transmitter/receiver system for signals up to 3G (1080p60) while preserving full uncompressed quality.

The OTT 1812-1 has two completely independent channels and each will auto-detect and re-clock any 270Mbit/s, 1.5Gbit/s, and 3Gbit/s SDI source before optical transmission. The module is fully compatible with 3G Level A and Level B formats.

Technical Specifications

SDI Input	2 x SDI video on 75 Ohm BNC connector (two independent channels)		
	SMPTE 424M, SMPTE 292M, SMPTE 259M, DVB-ASI		
	Multi-standard operation from 270Mbit/s to 3Gbit/s		
	Multi-rate relocking: 270Mbit/s - 1.5Gbit/s - 3Gbit/s		
Electrical Return Loss:		to 1.5GHz: >15dB	to 3GHz: >10dB
Automatic Cable EQ*:	270Mbit/s	1.5Gbit/s	3Gbit/s
	250m	190m	140m
	Belden 1694A cable		

Optical Output	2 x fiber optic outputs	
	Simplex (singlemode) using LC/PC Connections	
	SMPTE 297M - 2006	
Wavelength:	1310nm (each channel)	
Optical power:	-3dBm to -8dBm (each channel)	
	2x TX active LED on side of module	
Max. distance*	max. 10km* (6.2 miles) @ 3Gbit/s	

Power	+12V DC @ 1.9W nominal - (supports 7 - 24V DC input range)	
	Power LED on side of module	

Physical	Size	140mm x 42mm x 22mm (incl.connectors) (5.51" x 1.65" x 0.86")
	Weight	125g (4.4oz)

Ambient	5 - 40°C (41 - 104°F) 90% Humidity (non condensing)	
----------------	---	--

Model #	OTT 1842-1	EAN# 4250479318427
----------------	------------	--------------------

Includes	Module, SFP Module, AC power supply	
-----------------	-------------------------------------	--

*Distance is an approximation. Actual distances achieved can be longer or shorter depending on the type of cable. Determine link losses and perform optical budget calculations to ensure correct operation.

OTX 1842

3G SDI to Fiber Optic Transmitters [CWDM]



SFP shown is not included



Features

- Supports SDI video inputs up to 3G (1080p60)
- 3G Level A and Level B support (all formats)
- Auto reclocking 270Mbit/s, 1.5Gbit/s, and 3Gbit/s
- Reclocked SDI loop output
- 18 wavelength selections (ITU-T G.694.2)
- Up to 40km* (24.85 miles) @ 3Gbit/s
- Simplex LC singlemode optical connection

Description

The OTX 1842 is a compact CWDM SDI to fiber optic transmitter designed to combat the restrictions involved with the distribution of uncompressed broadcast quality video signals over long distances.

When paired with the fiber optic to SDI receiver (e.g. yellobrik ORX 1802) you have a very cost-effective optical transmitter/receiver system for signals up to 1080p60 (3Gbit/s), while preserving full uncompressed quality. Select from 18 wave-

lengths for full CWDM compatibility.

The OTX 1842 will auto-detect and re-clock any 270Mbit/s, 1.5Gbit/s, and 3Gbit/s SDI source prior to optical transmission. The module is fully compatible with 3G Level A and Level B formats.

Note: This yellobrik **DOES NOT INCLUDE** the fiber SFP module. Please specify the required SFP option from the option list.

Technical Specifications

SDI Video	1x SDI input on 75 Ohm BNC connector		
	1x SDI output reclocked loop on 75 Ohm BNC connector		
	SMPTE 424M, SMPTE 292M, SMPTE 259M, DVB-ASI		
	Multi-standard operation from 270Mbit/s to 3Gbit/s		
Multi-rate reclocking: 270Mbit/s - 1.5Gbit/s - 3Gbit/s			
Electrical Return Loss:		to 1.5GHz: >15dB	to 3GHz: >10dB
	270Mbit/s	1.5Gbit/s	3Gbit/s
	Automatic Cable EQ*:	250m	220m
Belden 1694A cable			
Optical Output	1 x fiber optic output - Simplex (singlemode) LC/PC connection		
	SMPTE 297M - 2006		
	Wavelength: CWDM selection. See select SFP table		
	Optical power: see selected SFP option		
TX active LED on side of module			
Power	+12V DC @ 1.9W nominal - (supports 7 - 24V DC input range)		
	Power LED on side of module		
Physical	Size	140mm x 42mm x 22mm (incl.connectors) (5.51" x 1.65" x 0.86")	
	Weight	125g (4.4oz)	
	Ambient 5 - 40°C (41 - 104°F) 90% Humidity (non condensing)		
Model #	OTX 1842	EAN# 4250479359857	
Includes	Module, AC power supply		

SFP Module Options

Option #	Wavelength (20nm increments)	TX Power	Max. Transmission	Max. Distance
OH-TX-4-XXXX-LC	1270 - 1610 nm	-4...+2dBm	3Gbit/s	10km*
OH-TX-8-XXXX-LC	1270 - 1610 nm	+1...+5dBm	3Gbit/s	40km*

*Distance is an approximation. Actual distances achieved can be longer or shorter depending on the type of cable. Determine link losses and perform optical budget calculations to ensure correct operation.

OTT 1842-1

Dual 3G SDI to Fiber Optic Transmitters [CWDM]



SFP shown is not included



Features

- Dual Channel
- Supports SDI video inputs up to 3G (1080p60)
- 3G Level A and Level B support (all formats)
- Auto reclocking 270M, 1.5G, and 3G
- 18 Wavelength selections (ITU-T G.694.2)
- Up to 40km* (24.8 miles) @ 3Gbit/s
- Duplex LC/PC single mode optical connections

Description

The OTT 1842-1 is a compact CWDM dual channel SDI to fiber optic transmitter designed to combat the restrictions involved with the distribution of uncompressed broadcast quality video signals over long distances. 18 wavelengths are available.

When combined with the dual-channel fiber optic to SDI receiver module ORR 1802-2, and the OCM 1891/1892 CWDM multiplexers you have a very cost-effective CWDM fiber system for up to 18 signals in a single fiber link.

The OTT 1842-1 has two completely independent channels. Each will auto-detect and re-clock any 270Mbit/s, 1.5Gbit/s, and 3Gbit/s SDI source before optical transmission. The module is fully compatible with 3G Level A and Level B formats.

Note: This yellobrik **DOES NOT INCLUDE** the fiber SFP module. Please specify the required SFP option from the option list.

Technical Specifications

SDI Input	2 x SDI video on 75 Ohm BNC connector (two independent channels)		
	SMPTE 424M, SMPTE 292M, SMPTE 259M, DVB-ASI		
	Multi-standard operation from 270Mbit/s to 3Gbit/s		
	Multi-rate reclocking: 270Mbit/s - 1.5Gbit/s - 3Gbit/s		
Electrical Return Loss:		to 1.5GHz: >15dB	to 3GHz: >10dB
	270Mbit/s	1.5Gbit/s	3Gbit/s
	Automatic Cable EQ*:	250m	140m
Belden 1694A cable			
Optical Output	2 x fiber optic outputs - Simplex (singlemode) using LC/PC Connections		
	SMPTE 297M - 2006		
	Wavelength: CWDM selection. See select SFP table		
	Optical power: see selected SFP option		
2x TX active LED on side of module			
Power	+12V DC @ 1.9W nominal - (supports 7 - 24V DC input range)		
	Power LED on side of module		
Physical	Size	140mm x 42mm x 22mm (incl.connectors) (5.51" x 1.65" x 0.86")	
	Weight	125g (4.4oz)	
	Ambient 5 - 40°C (41 - 104°F) 90% Humidity (non condensing)		
Model #	OTT 1842-1	EAN# 4250479318427	
Includes	Module, AC power supply		

SFP Module Options

Option #	Wavelength (20nm increments)	TT Power	Max. Transmission	Max. Distance
OH-TT-4-XXXX-LC	1270 - 1610 nm	-4...+2dBm	3Gbit/s	10km*
OH-TT-8-XXXX-LC	1270 - 1610 nm	+1...+5dBm	3Gbit/s	40km*

ORX 1400

12G Fiber Optic to Dual SDI Receiver



ORX 1400 LC Version Shown



Features

- Supports 12G, 6G, 3G, 1.5G, and 270M SDI video standards
- 3G Level A and Level B (support for all formats)
- Auto relocking 270Mbit/s, 1.5Gbit/s, 3Gbit/s, 6Gbit/s, and 12Gbit/s
- Two relocked SDI outputs
- LC/PC and ST/PC connection variants
- Singlemode fiber connection
- Input range 1260nm to 1620nm

Description

The ORX 1400 is a compact SDI to fiber optic Receiver designed to combat the restrictions involved with the distribution of uncompressed, high bandwidth, broadcast quality video signals over long distances.

When paired with the fiber optic to SDI transmitter (e.g. yellobrik OTX 1410) you have a very cost-effective optical transmission / receiver system for signals up to 12G (4096x2160 @ 60Hz), while preserving full uncompressed quality.

Operation of the ORX 1400 is fully automatic.

The SDI video format is automatically detected, relocked and provided on two SDI output connections.

The ORX 1400 supports 12G, 6G, 3G, 1.5G and 270M SDI video standards and is available in LC and ST variants.

Technical Specifications

Fiber Input	1	x	fiber	optic	input
	Simplex (singlemode) LC/PC, ST/PC connection				
	SMPTE 297M - 2006				
	Wavelength: 1260nm to 1620nm				
	RX Sensitivity -2dBm to -10dBm				
	RX active LED on side of module				
SDI Output	2 x SDI video on 75 Ohm BNC connectors				
	SMPTE 424M, SMPTE 292M, SMPTE 259M, DVB-ASI				
	Multi-standard operation from 270Mbit/s to 12Gbit/s				
	Multirate relocking: 270Mbit/s - 1.5Gbit/s - 3Gbit/s - 6Gbit/s - 12Gbit/s				
	Electrical Return Loss:	to 1.5GHz: >15dB	to 3GHz: >10dB	to 6GHz: >7dB	to 12GHz: >4dB
Power	+12V DC @ 2W nominal - (supports 7 - 24V DC input range)				
	Power LED on side of module				
Physical	Size (incl.connectors)	140mm x 42mm x 22mm (5.51" x 1.65" x 0.86")			
	Weight	125g (4.4oz)			
Ambient	5 - 40°C (41 - 104°F) 90% Humidity (non condensing)				
Model #	ORX 1400 LC	EAN# 4250479324732			
	ORX 1400 ST	EAN# 4250479327658			
Includes	Module, SFP Module, AC power supply				

ORR 1402

Dual 12G Fiber Optic to Dual SDI Receiver



Features

- Dual channel
- Supports 12G, 6G, 3G, 1.5G, 270M SDI video standards
- Auto relocking 270Mbit/s, 1.5Gbit/s, 3Gbit/s, 6Gbit/s, and 12Gbit/s
- 3G Level A and Level B (support for all formats)
- 1260nm to 1620nm wavelength input range
- Up to 10km (6.2 miles) @ 12Gbit/s (singlemode)
- 2x fiber optic inputs (LC Connector - singlemode)

Description

The ORR 1402 is a compact dual channel fiber optical to SDI receiver designed to combat the restrictions involved with the distribution of uncompressed broadcast quality video signals over long distances.

When paired with an SDI optical transmitter (e.g. yellobrik OTT 1412, OTX1410, OTX1440, etc.) the user will have a very cost-effective optical transmitter/receiver system for signals up to 12G (4096x2160 @ 60Hz), while preserving full uncompressed quality.

The ORR 1402 has two completely independent channels and each will auto-detect and re-clock any 270Mbit/s, 1.5Gbit/s, 3Gbit/s, 6Gbit/s, or 12Gbit/s SDI fiber source prior to electrical conversion. The module is fully compatible with 3G Level A and Level B formats.

Technical Specifications

Fiber Input	2	x	fiber	optic	input	(one for each channel)
	Duplex (singlemode) LC/PC connection					
	SMPTE 2082-1, SMPTE 2081-1, SMPTE 424M, SMPTE 292M, SMPTE 259M					
	Wavelength: 1260nm to 1620nm					
	RX Sensitivity -9dBm @ 12Gbit/s					-10dBm @ <12Gbit/s
	2x RX active LED on side of module					
SDI Output	2 x SDI video on 75 Ohm BNC connectors					
	SMPTE 2082-1, SMPTE 2081-1, SMPTE 424M, SMPTE 292M; SMPTE 259M					
	Multi-standard operation from 270Mbit/s to 12Gbit/s					
	Multirate relocking: 270Mbit/s - 1.5Gbit/s - 3Gbit/s - 6Gbit/s - 12Gbit/s					
	Electrical Return Loss:	to 1.5GHz: >15dB	to 3GHz: >10dB	to 6GHz: >7dB	to 12GHz: >4dB	
Power	+12V DC @ 1.9W nominal - (supports 7 - 24V DC input range)					
	Power LED on side of module					
Physical	Size (incl.connectors)	140mm x 42mm x 22mm (5.51" x 1.65" x 0.86")				
	Weight	125g (4.4oz)				
Ambient	5 - 40°C (41 - 104°F) 90% Humidity (non condensing)					
Model #	ORR 1402 EAN# 4250479326484					
Includes	Module, SFP Module, AC power supply					

*Distance is an approximation. Actual distances achieved can be longer or shorter depending on the type of cable. Determine link losses and perform optical budget calculations to ensure correct operation.

OTX 1712-2

Analog Sync/Video Fiber Optic Transmitter



OTX 1712-2 LC Version Shown

Features

- Supports analog black burst, bi- and tri-level sync signals
- Supports NTSC and PAL composite video
- Passive loop output
- Versions for LC, ST or SC fiber connections
- Up to 10km* (6.2 miles) singlemode
- Up to 300m* (984 feet) multimode
- yelloGUI and LynxCentraal compatible to access additional internal settings

Description

The OTX 1712-2 is a compact analog sync or NTSC/PAL composite video to fiber optic transmitter. This device is specifically designed to combat the restrictions involved with the distribution of broadcast quality analog reference and composite video signals over long distances.

When paired with the fiber optic receiver ORX 1702-1 you have a very cost-effective optical transmission system for analog sync reference signals or NTSC/PAL composite video. This device is particularly useful for reference sync distribution between remote installations to maintain correct synchronization.

Unlike other, very basic analog to fiber conversion solutions, the OTX 1712-2 incorporates technology to maintain a very high degree of sync and

burst phase stability during the conversion and fiber transmission.

The module converts the NTSC/PAL video signal to an SDI signal (including reference and other relevant information) before it is converted to fiber. Therefore, when the OTX 1712-2 is used for NTSC or PAL video sources it is possible to convert the fiber signal directly to SDI if required using an SDI receiver (e.g. ORX 1802).

The OTX 1712-2 provides a passive loop output and support for LC, ST or SC singlemode fiber connections. An LC version suitable for multimode fiber is also available.

Technical Specifications

Analog Input	1 x SDI Input (Sync or Video) 1 x passive loop output (terminate if not used) NTSC SMPTE 170M, PAL CCIR624 Analog tri-level sync SMPTE ST 274, ST 296 720p 50/59.94/60 1080i 50/59.94/60 1080p 23.97/24/25 1080psf 23.97/24 Multi-standard operation, auto-detect Return loss: 31dB to 10MHz
Fiber Out Singlemode	1 x fiber optic singlemode output - LC, ST or SC connection SMPTE 297M - 2006 Wavelength: 1310nm, Optical power -5dBm TX active LED on side of module Max. distance: 10km* (6.2 miles - approx)
Fiber Out Multimode	1 x fiber optic multimode output - LC/PC connection SMPTE 297M - 2006 Wavelength: 850nm, Optical power -5dBm TX active LED on side of module Max. distance: 300m (984feet - approx)
Power	+12V DC @ 3.4W nominal - (supports 8 - 24V DC input range)
Physical	Size (incl. connectors): 140 x 42 x 22mm (5.51" x 1.65" x 0.86") Weight: 125g (4.4oz)
Ambient	5 - 40°C (41 - 104°F) 90% Humidity (non condensing)
Model #	OTX 1712-2 LC - (EAN# 4250479323209) OTX 1712-2 ST - (EAN# 4250479324152) OTX 1712-2 SC - (EAN# 4250479324169) OTX 1712-2 MM (multimode) - (EAN# 4250479324176)
Includes	Module, 12V DC power supply, 2x SFP, 2x mini USB cable

OTX 1742-2

Analog Sync/Video Fiber Optic Transmitter [CWDM]



SFP shown is not included

Features

- Supports analog black burst, bi- and tri-level sync signals
- Supports NTSC and PAL composite video
- Passive loop analog output
- LC/PC fiber connection
- 18 wavelength selections (ITU-T G.694.2)
- Up to 40km* (24.8 miles) singlemode
- yelloGUI and LynxCentraal compatible to access additional internal settings

Description

The OTX 1742-2 is a compact analog sync or NTSC/PAL composite video to fiber optic transmitter (CWDM compatible). This device is specifically designed to combat the restrictions involved with the distribution of broadcast quality analog reference and composite video signals over long distances.

When paired with the fiber optic receiver ORX 1702-1 you have a cost-effective optical transmission system for analog sync reference signals or NTSC/PAL composite video. This device is particularly useful for reference sync distribution between remote installations to maintain correct synchronization.

Unlike other very basic analog to fiber conversion

solutions, the OTX 1742-2 incorporates technology to maintain a very high degree of sync and burst phase stability during the conversion and fiber transmission.

The module converts the NTSC/PAL video signal to an SDI signal (including reference and other relevant information) before it is converted to fiber. Therefore, when the OTX 1742-2 is used for NTSC or PAL video sources it is possible to convert the fiber signal directly to SDI if required using an SDI receiver (e.g. ORX 1802).

Note: This yellobrik **DOES NOT INCLUDE** the fiber SFP module. Please specify the required SFP option from the option list.

Technical Specifications

Analog Input	1 x SDI Input (Sync or Video) 1 x passive loop output (terminate if not used) NTSC SMPTE 170M, PAL CCIR624 Analog tri-level sync SMPTE ST 274, ST 296 720p 50/59.94/60 1080i 50/59.94/60 1080p 23.97/24/25 1080psF 23.97/24 Multi-standard operation, auto-detect Return loss: 31dB to 10MHz
Fiber Out Singlemode	1 x fiber optic singlemode output - LC/PC connection SMPTE 297M - 2006 18 Wavelength selections per ITU-T G.694.2 (see table) TX active LED on side of module Max. distance approx. 40km (24.8 miles)
Power	+12V DC @ 3.5W nominal (supports 8 - 24V DC input range)
Physical	Size (incl. connectors): 140 x 42 x 22mm (5.51" x 1.65" x 0.86") Weight: 125g (4.4oz)
Ambient	5 - 40°C (41 - 104°F) 90% Humidity (non condensing)
Model #	OTX 1742-2 - (EAN# 4250479324183)
Includes	Module, 12V DC power supply, mini USB cable

SFP Module Options

Option #	Wavelength (20nm increments)	TX Power	Max. Transmission	Max. Distance
OH-TX-4-XXXX-LC	1270 - 1610 nm	-4...+2dBm	3Gbit/s	10km*
OH-TX-8-XXXX-LC	1270 - 1610 nm	+1...+5dBm	3Gbit/s	40km*

*Distance is an approximation. Actual distances achieved can be longer or shorter depending on the type of cable. Determine link losses and perform optical budget calculations to ensure correct operation.

ORX 1702-1 Analog Sync/Video Fiber Optic Receiver



ORX 1702-1 LC Version Shown

Visit the product page:



Features

- Supports analog black burst, bi-level, tri-level sync signals
- Supports NTSC and PAL composite video
- Two outputs
- Versions for LC, ST or SC fiber connections
- Multimode version available
- Input range 1260nm to 1620nm (singlemode) (supports CWDM)
- yelloGUI and LynxCentra compatible to access additional internal settings

Description

The ORX 1702-1 is a compact analog sync or NTSC/PAL composite video to fiber optic receiver. This device is specifically designed to combat the restrictions involved with the distribution of broadcast quality analog reference and composite video signals over long distances.

When paired with the fiber optic transmitter OTX 1712-2 you have a very cost-effective optical transmission system for analog sync reference signals or NTSC/PAL composite video. This device is particularly useful for reference sync distribution between remote installations to maintain correct synchronization.

Unlike other very basic analog to fiber conversion solutions, the ORX 1702-1 incorporates technology to maintain a very high degree of sync and burst phase stability during the fiber reception and analog conversion.

The module receives an SDI signal (including reference and other relevant information) before it is converted to an analog signal. Therefore, when the ORX 1702-1 is used for 525 or 625 SDI video sources it is possible to convert the signal to an analog NTSC or PAL composite output directly. For example: if the 525 or 625 signal is received from an SDI video transmitter OTX 1812.

The ORX 1702-1 provides two analog outputs and support for LC, ST or SC singlemode fiber connections. An LC version suitable for multimode fiber is also available.

Technical Specifications

Fiber Input Singlemode	1 x fiber optic Input - LC/PC, ST/PC or SC/PC connection SMPTE 297M - 2006 Input range (wavelength): 1260nm to 1620nm RX sensitivity: -3dBm to -19dBm RX active LED on side of module
Fiber Input Multimode	1 x fiber optic input - LC/PC connection SMPTE 297M - 2006 Input range (wavelength) 780nm to 880nm RX sensitivity: 0dBm to -15dBm RX active LED on side of module
Analog Output	2 x 75 Ohm BNC for Sync or Video NTSC SMPTE 170M, PAL CCIR624 Analog tri-level sync SMPTE ST 274, ST 296 720p 50/59.94/60 1080i 50/59.94/60 1080p 23.97/24/25 1080psF 23.97/24 Return loss: 46.5dB to 10MHz
Power	+12V DC @ 3.5W nominal - (supports 8 - 24V DC input range)
Physical	Size: 140mm x 42mm x 22mm (5.51" x 1.65" x 0.86") incl connectors Weight: 125g (4.4oz)
Ambient	5 - 40°C (41 - 104°F) 90% Humidity (non condensing)
Model #	ORX 1702-1 LC - (EAN# 4250479320383) ORX 1702-1 ST - (EAN# 4250479320390) ORX 1702-1 SC - (EAN# 4250479320406) ORX 1702-1 MM (multimode) - (EAN# 4250479320413)
Includes	Module, 12V DC power supply, SFP, mini USB cable

Fiber Adapter Options

These adapter kits allow the use of ST or SC fiber connections on the module. SMF 0.5m (19.6") tail introduces less than 0.25dB attenuation.

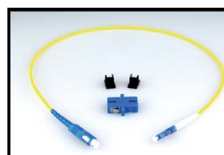

Model# **LC/SC SIM**
LC/PC to SC/PC Adapter

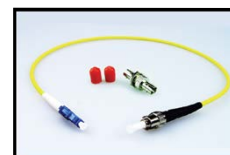

Model# **LC/ST SIM**
LC/PC to ST/SC Adapter

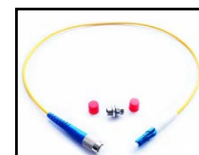

Model# **LC/FC SIM**
LC/PC to FC/PC Adapter

*Distance is an approximation. Actual distances achieved can be longer or shorter depending on the type of cable. Determine link losses and perform optical budget calculations to ensure correct operation.

OET 1910

10Gbit/s Ethernet/Fiber Optic Transceiver



Features

- Supports standard Ethernet/Optical signals of 10Gbit/s or 1Gbit/s
- Allows Fiber to Copper and Copper to Fiber conversion
- 2x 10Gbit/s transceiver ports (Electrical/Optical) per module
- Maximum throughput of 20Gbit/s (full duplex)
- Distances up to 20km (12.4 miles) over singlemode fiber*
- Power and signal present LED indication

Description

The OET 1910 is a compact electrical ethernet to fiber optic converter, designed to extend the reach of 1Gbit/s or 10Gbit/s electrical ethernet networks over long distances.

When paired with another OET 1910 (using two fiber links) you have a simple cost-effective ethernet extender solution for distances up to 20km* providing a stable, high-speed optical ethernet connection between locations.

Technical Specifications

SFP Slots	2 x 10 Gigabit SFP+ slots (Port 1 & 2) Supports 10GBase-T SFP, 10GBase-X, 1000Base-T IEEE 802.3ae
Port 1	10Gbit/s Base Optical Long Reach+ Transceiver SFP 1310nm wavelength - singlemode Duplex LC connector TX Optical Power: -3 to +1dBm / RX Sensitivity: -14.4dBm Max. distance up to 20km (~12.4 ml)*
	10Gbit/s Base Optical Multimode Transceiver SFP 850nm wavelength - multimode Duplex LC connector TX Optical Power: -6 to -1dBm / RX Sensitivity: -11dBm Max. distance up to 300m (~984.2 ft)* - 50/125µ OM3
	10Gbit/s Base Electrical I/O SFP 10 Gigabit Ethernet via Cat6a/Cat7 cable RJ-45 connector Max. distance up to 30m (~98.4ft)*
LED	3 x LED (1x Power LED) (2x Signal present LED)
Power	+12V DC @ 4W with SFPs (supports 7 - 15V DC input range)
Physical	Size: 120mm x 42mm x 22mm (4.73" x 1.65" x 0.86") including connectors Weight: 125g (4.4oz)
Ambient	5 - 40°C (41 - 104°F) 90% humidity (non condensing)
Model #	OET 1910 (EAN# 4250479328358) OET 1910 MM (EAN# 4250479328365)
Includes	Module, Power Supply, Quick Reference Guide

OBD 1910

10Gbit/s Ethernet/Bidirectional Fiber Optic Transceiver



Features

- Supports standard Ethernet/Optical signals of 10Gbit/s or 1Gbit/s
- Maximum throughput of 20Gbit/s (full-duplex)
- Includes 2 modules and 2 power supplies
- Power and signal present LED indication
- Simple plug and play operation
- Extend 10Gbit/s Ethernet up to 30km* (18.6 miles) via single bidirectional fiber

Description

The OBD 1910 kit is a simple, easy to use, plug and play solution to extend a 10Gbit/s or 1Gbit/s electrical Ethernet network up to 30km* over a single fiber link. Usually 2 fiber links are needed between locations (TX and RX) but the OBD 1910 uses WDM multiplexing to use a single, bidirectional fiber link (singlemode fiber)

The kit includes 2 Modules and 2 power supplies, just make the network connections and connect the fiber and you are all set. The modules supports 10Gbit/s and 1Gbit/s Ethernet networks

with a maximum throughput of 20Gbit/s (full duplex)

If your current network infrastructure is using multimode fiber the OBD 1910 MM kit is required. It converts duplex LC multimode RX and TX connections into a single bidirectional link using singlemode fiber for long distances.

Technical Specifications

SFP Slots	2 x 10 Gigabit SFP+ slots (Port 1 & 2) Supports 10GBase-T SFP, 10GBase-X, 1000Base-T IEEE 802.3ae
Port 1	10Gbit/s Base Optical Bidirectional Transceiver SFP 1270nm and 1330nm wavelength - bidirectional (WDM) Simplex LC connector TX Optical Power: max. 0 to 5dBm / RX Sensitivity: -15dBm Max. distance up to 30km (~18.6ml)*
	10Gbit/s Base Optical Multimode Transceiver SFP 850nm wavelength - multimode Duplex LC connector TX Optical Power: -6 to -1dBm / RX Sensitivity: -11dBm Max. distance up to 300m (~984.2 ft)* - 50/125µ OM3
Port 2	10Gbit/s Base Electrical I/O SFP 10 Gigabit Ethernet RJ-45 connector via Cat6a/Cat7 cable Max. distance up to 30m (~98.4ft)*
	LED
Power (per module)	+12V DC @ 4W with SFPs (supports 7 - 15V DC input range)
Physical (per module)	Size: 120mm x 42mm x 22mm (4.73" x 1.65" x 0.86") including connectors Weight: 125g (4.4oz)
Ambient	5 - 40°C (41 - 104°F) 90% humidity (non condensing)
Model #	OBD 1910 E (EAN# 4250479328334) OBD 1910 MM (EAN# 4250479328341)
Includes	2x Modules, 2x Power Supplies, Quick Reference Guide

*Distance is an approximation. Actual distances achieved can be longer or shorter depending on the type of cable. Determine link losses and perform optical budget calculations to ensure correct operation.

OET 1940 (MS/MC) 10Gbit/s Ethernet to Fiber Transceiver



Video

Audio

Data

Optical

Racks

Optional

Features

- Supports standard Ethernet/Optical signals of 10Gbit/s or 1Gbit/s
- Solutions provided for:
 - » *Electrical to CWDM fiber conversion*
 - » *Multimode Fiber to singlemode Fiber conversion*
 - » *Multimode to CWDM Fiber conversion*
- 2x 10Gbit/s transceiver ports (Electrical/Optical)
- Maximum throughput of 20Gbit/s (full duplex)
- Supports distances up to 25km (15.5 miles) over singlemode fiber*
- Power and signal present LED indication
- Supports hot swapping and hot plugging

Description

The OET 1940 are a range of variants to convert CWDM and MM fiber optic ethernet signals and extend the reach of 1Gbit/s or 10Gbit/s electrical ethernet signals over long distances.

The following variations are available:

OET 1940 (Copper ◀▶ CWDM)

This basic variant is an electrical RJ-45 to CWDM multiplexed fiber optic converter. The module includes a 10Gbit/s RJ45 electrical SFP.

The CWDM SFP has to be purchased separately. Please refer to the table below to find a suitable model.

OET 1940 MC (Multimode ◀▶ CWDM)

The optical multimode to optical CWDM converter. The module includes a multimode SFP.

The CWDM SFP has to be purchased separately. Please refer to the table below to find a suitable model.

OET 1940 MS (Multimode ◀▶ Singlemode)

The optical multimode to optical single mode converter variant. The module includes the multimode and single mode SFPs, each with two fiber connections, one for TX and one for RX (LC connections)

Ordering Info:

The **OET 1940** and its variant prices **DO NOT INCLUDE** the fiber transmitter SFP module unless it is specified when ordered.

When ordering please specify the required wavelength by replacing the XXXX in the Option #

SFP Module Options

Option #	Wavelength (20nm increments)	TX Power	RX Sensitivity	Data Rates
OH-TR-10G-XXXX-LC	1270 - 1610 nm	0 ... 4dBm	-23dBm	10Gbit/s, 1Gbit/s

Technical Specifications

SFP Slots	2 x 10 Gigabit SFP+ slots (Port 1 & 2)
	Supports 10GBase-T SFP, 10GBase-X, 1000Base-T
	IEEE 802.3ae
Port 1	10Gbit/s Base Optical Long Reach+ Transceiver SFP (OET 1940 MS)
	1310nm wavelength - singlemode
	Duplex LC connector
	TX Optical Power: -3 to +1dBm / RX Sensitivity: -14.4dBm
	Max. distance up to 20km (~12.4 ml)*
Port 2	10Gbit/s Base Optical CWDM Transceiver SFP (OET 1940 MC)
	1470/1490/1510/1530/1550/1570/1590/1610nm wavelength
	Duplex LC connector
	TX Optical Power: max. 0 to 4dB / RX Sensitivity: -23 dBm
	Max. distance up to 25km (~15.5ml)*
Port 2	10Gbit/s Base Electrical I/O SFP (OET 1940)
	10 Gigabit Ethernet via Cat6a/Cat7 cable
	RJ-45 connector
	Max. distance up to 30m (~98.4ft)*
Port 2	10Gbit/s Base Optical Multimode Transceiver SFP (OET 1940 MC)
	850nm wavelength - multimode
	Duplex LC connector
	TX Optical Power: -6 to -1dBm / RX Sensitivity: -11dBm
	Max. distance up to 300m (~984.2 ft)* - 50/125µ OM3
LED	3 x LED (1x Power LED) (2x Signal present LED)
Power	+12V DC @ 4.6W with SFPs (supports 7 - 15V DC input range)
Physical	Size: 120mm x 42mm x 22mm (4.73" x 1.65" x 0.86") including connectors Weight: 125g (4.4oz)
Ambient	5 - 40°C (41 - 104°F) 90% humidity (non condensing)
Model #	OET 1940 (EAN# 4250479328372) OET 1940 MC (EAN# 4250479328396) OET 1940 MS (EAN# 4250479328389)
Includes	Module, Power Supply, SFP(s) as per module description

Fiber Adapter Options

These adapter kits allow the use of ST or SC fiber connections on the module. SMF 0.5m (19.6") tail introduces less than 0.25dB attenuation.

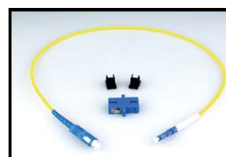

Model# **LC/SC SIM**
LC/PC to SC/PC Adapter

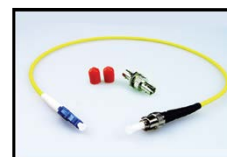

Model# **LC/ST SIM**
LC/PC to ST/SC Adapter



Model# **LC/FC SIM**
LC/PC to FC/PC Adapter

*Distance is an approximation. Actual distances achieved can be longer or shorter depending on the type of cable. Determine link losses and perform optical budget calculations to ensure correct operation.

OET 1514

1Gbit/s Ethernet/Fiber Optic Transceiver



Features

- Supports standard ethernet inputs up to 1 Gbit/s
- 3 port ethernet switch (1 fiber, 2 electrical)
- Auto (10/100/1000) port speed detection
- Manually force 10Mbit/s electrical speed (if needed)
- Fiber transceiver speed always 1 Gbit/s
- Auto or manual electrical crossover selection
- Distances up to 10km(6.2 miles)* over fiber
- 2 SFP selections (Singlemode and Multimode)
- Status monitoring via USB and LynxCentraal

Description

The OET 1514 is a compact 3 port ethernet switch, designed to extend the reach of electrical ethernet signals over long distances using a constant (fixed) high speed 1 Gbit/s optical transceiver speed.

When paired with another OET 1510 at the receiving end (using two fiber links) you have a cost effective Ethernet extender system for distances up to 10km providing a stable, high speed 1Gbit/s error free optical connection between locations.

The OET 1514 has two standard RJ45 electrical

ethernet ports plus fiber I/O and functions as a 3 port ethernet switch. For legacy system use: each electrical ethernet port can be set for automatic speed detection (10/100/1000) or forced to 10Mbit/s, and each port can use auto crossover detection or be forced manually if needed. These functions are available using the dip switch.

Note: This yellobrik **DOES NOT INCLUDE** the fiber SFP module. Please specify the required SFP option from the option list.

Technical Specifications

Ethernet	2 x Ethernet ports, RJ 45 Connectors. 10 BaseTUTP category 3,4 or 5 cable up to 328ft/100m (2 pairs) 100 BaseTXUTP category 5 cable up to 328ft/100m (2 pairs) 1000 BaseTXUTP category 5 cable up to 328ft/100m (4 pairs) Auto detect bit rate (10/100/1000), or force to 10Mbit/s for each port Auto crossover detection or force manually for each port (selectable) Port speed / activity LED indication (next to Ethernet port)
Fiber Optic	1 x fiber optic input (RX), 1 x fiber optic output (TX) Duplex using LC/PC Connections IEEE 802.3z (1000BASE-X Gbit/s Ethernet over Fiber at 1Gbit/s (125MB/s)) Singlemode Version TX wavelength 1310nm, power -3dBm RX input range 1260nm to 1620nm, sensitivity -3dBm to -21dBm Max distance 10km (6.2miles) Multimode Version TX wavelength 850nm, power -2dBm to -7dBm RX input 850nm sensitivity 0dBm to -15dBm Max distance approx 550m (1804 feet) Fiber TX active and RX active LEDs on side of module
Power	+12V DC @ 1.7W nominal without SFP (supports 7 - 22V DC input range)
Physical	Size (incl. connectors): 120mm x 42mm x 22mm (4.73" x 1.65" x 0.86") Weight: 125g (4.4oz)
Ambient	5 - 40°C (41 - 104°F) 90% Humidity (non condensing)
Model #	OET 1514 (EAN# 4250479329447)
Includes	Module, AC power supply, SFP, mini USB cable

SFP Module Options

Base price **DOES NOT INCLUDE** the fiber transmitter SFP. Please specify the required SFP from the option list.

Option #	Wavelength	TX Power	RX Sensitivity	Distance*
OH-TR-51-LC	1310nm	-3 dBm	-23dBm	10km* (6.2mi)
OH-TR-50-850-MM	850nm	-2 ... -7dBm	-15dBm	550m* (1800ft)

*Distance is an approximation. Actual distances achieved can be longer or shorter depending on the type of cable. Determine link losses and perform optical budget calculations to ensure correct operation.

OET 1510

1Gbit/s Ethernet/Fiber Optic Transceiver

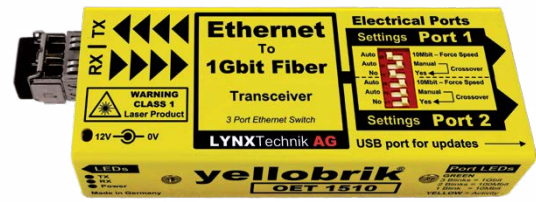

Features

- Supports standard Ethernet inputs up to 1Gbit/s
- 3 port Ethernet switch (1 fiber, 2 electrical)
- Auto (10/100/1000) electrical port speed detection
- Manually force 10Mbit/s electrical speed (if needed)
- Fiber transceiver speed always 1Gbit/s
- Auto or manual electrical crossover selection
- Singlemode fiber 1310nm up to 10km (6.2 miles)
- Multimode fiber 850nm up to 550m (1,804 feet)
- Duplex LC optical connections

Description

The OET 1510 is a compact 3 port Ethernet switch, designed to extend the reach of electrical Ethernet signals over long distances using a constant (fixed) high speed 1Gbit/s optical transceiver speed.

When paired with another OET 1510 at the receiving end (using two fiber links) you have a cost-effective Ethernet extender system for distances up to 10km providing a stable, high speed 1Gbit/s error free optical connection between locations.

The OET 1510 has two standard RJ45 electrical

ethernet ports plus fiber I/O and functions as a 3 port Ethernet switch. For legacy system use; each electrical Ethernet port can be set for automatic speed detection (10/100/1000) or forced to 10Mbit/s, and each port can use auto crossover detection or be forced manually if needed. These functions are available using the dip switch.

Note: This yellobrik **DOES NOT INCLUDE** the fiber SFP module. Please specify the required SFP option from the option list.

Technical Specifications

Ethernet	2 x Ethernet ports, RJ 45 Connectors. 10 BaseTUTP category 3,4 or 5 cable up to 328ft/100m (2 pairs) 100 BaseTXUTP category 5 cable up to 328ft/100m (2 pairs) 1000 BaseTXUTP category 5 cable up to 328ft/100m (4 pairs) Auto detect bit rate (10/100/1000), or force to 10Mbit/s for each port Auto crossover detection or force manually for each port (selectable) Port speed / activity LED indication (next to Ethernet port)
Fiber Optic	1 x fiber optic input (RX), 1 x fiber optic output (TX) Duplex using LC/PC Connections IEEE 802.3z (1000BASE-X Gbit/s Ethernet over Fiber at 1Gbit/s (125MB/s)) Singlemode Version TX wavelength 1310nm, power -3dBm RX input range 1260nm to 1620nm, sensitivity -3dBm to -21dBm Max distance 10km (6.2miles) Multimode Version TX wavelength 850nm, power -2dBm to -7dBm RX input 850nm sensitivity 0dBm to -15dBm Max distance approx 550m (1804 feet) Fiber TX active and RX active LEDs on side of module
Power	+12V DC @ 2.2W nominal - (supports 7 - 15V DC input range)
Physical	Size (incl. connectors): 120mm x 42mm x 22mm (4.73" x 1.65" x 0.86") Weight: 125g (4.4oz)
Ambient	5 - 40°C (41 - 104°F) 90% Humidity (non condensing)
Model #	OET 1510 (singlemode) - (EAN# 4250479315129) OET 1510 MM (multimode) - (EAN # 4250479321144)
Includes	Module, AC power supply, SFP, mini USB cable

OET 1544

1Gbit/s Ethernet/Fiber Optic Transceiver - Switch [CWDM]



Features

- Supports standard Ethernet inputs up to 1Gbit/s
- 3 port Ethernet switch (1 fiber, 2 electrical)
- Auto (10/100/1000) port speed detection
- Manually force 10Mbit electrical speed (if needed)
- Fiber transceiver speed always 1Gbit/s
- Auto or manual electrical crossover selection
- Distances up to 40km* (24.8 miles) over fiber
- Status monitoring via USB and LynxCentraal

Description

The OET 1544 is a compact CWDM compatible ethernet 3 port switch, designed to extend the reach of electrical ethernet signals over long distances using a constant (fixed) high speed 1 Gbit/s optical transceiver speed.

18 selectable CWDM wavelengths are provided to enable the module to be used in a multiplexed CWDM environment. When paired with another OET 1544 at the receiving end (using two fiber links) you have a cost-effective Ethernet extender system for distances up to 40km* - providing a stable, high speed 1Gbit/s error free optical con-

nection between locations.

The OET 1544 has two standard RJ45 electrical ethernet ports plus fiber I/O and functions as a 3 port ethernet switch. For legacy system use; each electrical ethernet port can be set for automatic speed detection (10/100/1000) or forced to 10 Mbit/s, and each port can use auto crossover detection or be forced manually if needed. These functions are available using the dip switch.

Note: This yellobrik **DOES NOT INCLUDE** the fiber SFP module. Please specify the required SFP option from the option list.

Technical Specifications

Ethernet	2 x Ethernet ports, RJ 45 Connectors. 10 BaseTUTP category 3,4 or 5 cable up to 328ft/100m (2 pairs) 100 BaseTXUTP category 5 cable up to 328ft/100m (2 pairs) 1000 BaseTXUTP category 5 cable up to 328ft/100m (4 pairs) Auto detect bit rate (10/100/1000), or force to 10Mbit/s for each port (selectable) Auto crossover detection or force manually for each port (selectable) Port speed / activity LED indication (next to Ethernet port)
Fiber Optic (optional)	1 x fiber optic input (Range 1270-1610nm, Sensitivity -3dBm to -23dBm) 1 x fiber optic output CWDM (ITU-T G.694.2) 18 selectable wavelengths Duplex (Single mode) using LC/PC Connections IEEE 802.3z (1000BASE-X Gbit/s Ethernet over Fiber at 1 Gbit/s (125 MB/s) Fiber TX active and RX active LEDs on side of module Max. distance approx. 40km* (24.8 miles - Singlemode)
Power	+12V DC @ 1.7W nominal without SFP (supports 7 - 22V DC input range)
Physical	Size (incl. connectors) : 120mm x 42mm x 22mm (4.73" x 1.65" x 0.86") Weight: 125g (4.4oz)
Ambient	5 - 40°C (41 - 104°F) 90% Humidity (non condensing)
Model #	OET 1544 (EAN# 4250479329454)
Includes	Module, AC power supply, mini USB cable

SFP Module Options

Base price **DOES NOT INCLUDE** the fiber transmitter SFP. Please specify the required SFP from the option list.

Option #	Wavelength	TX Power	RX Sensitivity	Distance*
OH-TR-58-XXXX-LC	1270 - 1610nm	0 to +5dBm	-23dBm	80km* (49.7 miles)
OH-TR-54-XXXX-LC	1270 - 1610nm	-5 to 0dBm	-23dBm	40km* (24.6 miles)

*Distance is an approximation. Actual distances achieved can be longer or shorter depending on the type of cable. Determine link losses and perform optical budget calculations to ensure correct operation.

OET 1540

1Gbit/s Ethernet/Fiber Optic Transceiver - Switch [CWDM]

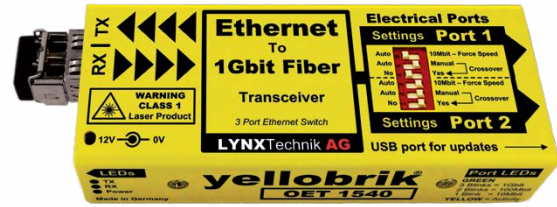

Features

- Supports standard Ethernet inputs up to 1Gbit/s
- 3 port Ethernet switch (1 fiber, 2 electrical)
- Auto (10/100/1000) port speed detection
- Manually force 10Mbit electrical speed (if needed)
- Fiber transceiver speed always 1Gbit/s
- Auto or manual electrical crossover selection
- Distances up to 40km* (24.8 miles) over fiber

Description

The OET 1540 is a compact CWDM compatible Ethernet 3 port switch, designed to extend the reach of electrical Ethernet signals over long distances using a constant (fixed) high speed 1Gbit/s optical transceiver speed.

When paired with another OET 1540 at the receiving end you have a cost-effective ethernet extender system for distances up to 40km providing a stable, high speed 1Gbit/s optical connection between locations.

This yellobrik has two standard RJ45 electrical

ethernet ports plus fiber I/O and functions as a 3 port ethernet switch. For legacy system use; each electrical Ethernet port can be set for automatic speed detection (10/100/1000) or forced to 10Mbit/s, and each port can use auto crossover detection or be forced manually if needed. These functions are available using the dip switch.

Note: This yellobrik **DOES NOT INCLUDE** the fiber SFP module. Please specify the required SFP option from the option list.

Technical Specifications

Ethernet	2 x Ethernet ports, RJ 45 Connectors. 10 BaseTUTP category 3,4 or 5 cable up to 328ft/100m (2 pairs) 100 BaseTXUTP category 5 cable up to 328ft/100m (2 pairs) 1000 BaseTXUTP category 5 cable up to 328ft/100m (4 pairs) Auto detect bit rate (10/100/1000), or force to 10Mbit/s for each port (selectable) Auto crossover detection or force manually for each port (selectable) Port speed / activity LED indication (next to Ethernet port)
Fiber Optic (optional)	1 x fiber optic input (Range 1270-1610nm, Sensitivity -3dBm to -23dBm) 1 x fiber optic output CWDM (ITU-T G.694.2) 18 selectable wavelengths Duplex (Single mode) using LC/PC Connections IEEE 802.3z (1000BASE-X Gbit/s Ethernet over Fiber at 1 Gbit/s (125 MB/s) Fiber TX active and RX active LEDs on side of module Max. distance approx. 40km* (24.8 miles - Singlemode)
Power	+12V DC @ 1.5W nominal without SFP +12V DC @ 2.3W nominal with SFP (supports 7 - 15V DC input range)
Physical	Size (incl. connectors) : 120mm x 42mm x 22mm (4.73" x 1.65" x 0.86") Weight: 125g (4.4oz)
Ambient	5 - 40°C (41 - 104°F) 90% Humidity (non condensing)
Model #	OET 1540 - (EAN# 4250479315426)
Includes	Module, AC power supply, mini USB cable

OBID 1514 E

1Gbit/s Ethernet/Bidirectional Fiber Optic Transceiver

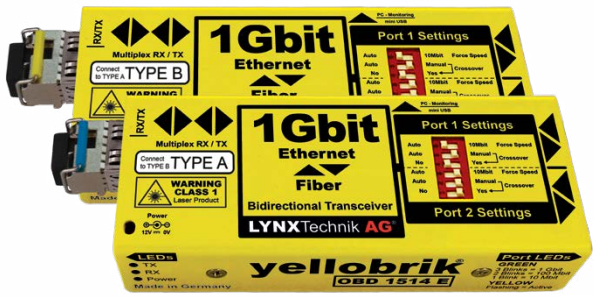

Features

- Bidirectional send and receive over single fiber link
- Supports standard ethernet inputs up to 1 Gbit/s
- Closed loop WDM fiber system
- 3 port ethernet switch (1 fiber, 2 electrical)
- Auto (10/100/1000) port speed detection
- Manually force 10Mbit/s electrical speed (if needed)
- Fiber transceiver speed always 1 Gbit/s
- Auto or manual electrical crossover selection
- Distances up to 10km(6.2 miles)* over singlemode fiber
- Status monitoring via USB and LynxCentraal

Description

The OBID 1514 E is a matched pair of compact ethernet switches designed to extend the reach of electrical ethernet signals over long distances. The two switches are linked via single bidirectional fiber link which operates at a constant 1Gbit/s speed.

This pair of modules uses WDM (Wavelength-division Multiplexing) fiber technology in a closed loop arrangement and essentially functions as an Ethernet extender solution. The fiber link supports distances up to 10km* and provides a single, high speed 1Gbit/s error-free optical connection between the two locations.

Each OBID 1514 E module has two standard RJ45

electrical Ethernet ports and the complete system functions as a 4 port ethernet switch, providing two standard RJ45 ethernet ports at each location bridged with fiber. For legacy systems, each electrical ethernet port can be set for automatic speed detection (10/100/1000) or forced to 10Mbit/s. Each port uses auto crossover detection or can be forced manually if needed. These functions are available using the dip switch.

Note: This system used WDM optical multiplexing and should only be used in point to point applications. This solution cannot be integrated into a CWDM multiplexed system.

Technical Specifications

Ethernet	2 x Ethernet ports, RJ45 Connectors. 10 BaseT UTP category 3,4 or 5 cable up to 328ft/100m (2 pairs) 100 BaseT XUTP category 5 cable up to 328ft/100m (2 pairs) 1000 BaseT XUTP category 5 cable up to 328ft/100m (4 pairs) Auto detect bit rate (10/100/1000), or force to 10Mbit/s for each port (selectable) Auto crossover detection or force manually for each port (selectable) Port speed / activity LED indication (next to Ethernet port)
Fiber Optic	1 x fiber optic I/O port (bidirectional) Simplex (single mode) using LC/PC connection WDM using 1310nm and 1550nm wavelengths Optical budget = 18dB Fiber TX active and RX active LEDs on side of module Maximum distance approx. 10km (6.2 miles - Singlemode)
Power (per module)	+12V DC @ 1.7W nominal without SFP (supports 7 - 22V DC input range)
Physical (per module)	Size (incl connectors): 120 x 42 x 22mm (4.73" x 1.65" x 0.86") Weight: 125g (4.4oz)
Ambient	5 - 40°C (41 - 104°F) 90% Humidity (non condensing)
Model #	OBID 1514-E (EAN# 4250479329416)
Includes	2 x modules (Type A and Type B), 2 x AC power supplies, 2x SFP, 2x mini USB cable

OBID 1510 E

1Gbit/s Ethernet/Bidirectional Fiber Optic Transceiver

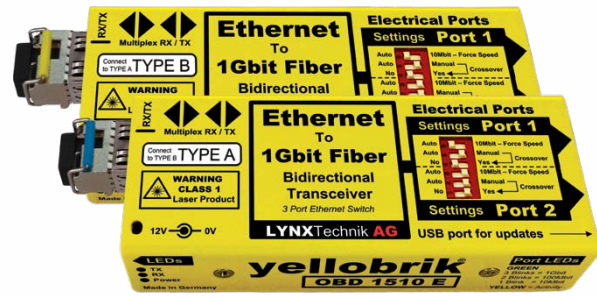

Features

- Bidirectional send and receive over single fiber link
- Supports standard Ethernet inputs up to 1Gbit/s
- Closed loop WDM fiber system
- Auto (10/100/1000) electrical port speed detection
- Manually force 10Mbit electrical speed
- Fiber connection speed always 1Gbit/s
- Auto or manual electrical crossover selection
- Distances up to 10km (6.2 miles)* over SMF fiber
- Supplied as matched pair (A and B version)

Description

The OBID 1510 E is a matched pair of compact ethernet switches designed to extend the reach of electrical ethernet signals over long distances. The two switches are linked via single bidirectional fiber link which operates at a constant 1Gbit/s speed.

This pair of modules uses WDM fiber technology in a closed loop arrangement and essentially functions as an ethernet extender solution. The fiber link supports distances up to 10km and provides a single, high speed 1Gbit/s, optical connection between the two locations.

Each OBID 1510 E module has two standard RJ45 electrical ethernet ports and the complete sys-

tem functions as a 4 port ethernet switch, providing two standard RJ45 ethernet ports at each location bridged with fiber. For legacy systems, each electrical ethernet port can be set for automatic speed detection (10/100/1000) or forced to 10Mbit/s. Each port uses auto crossover detection or can be forced manually if needed. These functions are available using the dip switch.

Note: This system used WDM optical multiplexing and should only be used in point to point applications. This solution cannot be integrated into a CWDM multiplexed system.

Technical Specifications

Ethernet	2 x Ethernet ports, RJ45 Connectors. 10 BaseT UTP category 3,4 or 5 cable up to 328ft/100m (2 pairs) 100 BaseT XUTP category 5 cable up to 328ft/100m (2 pairs) 1000 BaseT XUTP category 5 cable up to 328ft/100m (4 pairs) Auto detect bit rate (10/100/1000), or force to 10Mbit/s for each port (selectable) Auto crossover detection or force manually for each port (selectable) Port speed / activity LED indication (next to Ethernet port)
Fiber Optic	1 x fiber optic I/O port (bidirectional) Simplex (single mode) using LC/PC connection WDM using 1310nm and 1550nm wavelengths Optical budget = 18dB Fiber TX active and RX active LEDs on side of module Maximum distance approx. 10km (6.2 miles - Singlemode)
Power (per module)	+12V DC @ 1.9W nominal - (supports 7 - 15V DC input range)
Physical (per module)	Size (incl connectors): 120 x 42 x 22mm (4.73" x 1.65" x 0.86") Weight: 125g (4.4oz)
Ambient	5 - 40°C (41 - 104°F) 90% Humidity (non condensing)
Model #	OBID 1510 E - (EAN# 4250479319110)
Includes	2 x modules (Type A and Type B), 2 x AC power supplies, 2x SFP, 2x mini USB cable

*Distance is an approximation. Actual distances achieved can be longer or shorter depending on the type of cable. Determine link losses and perform optical budget calculations to ensure correct operation.

Video
Audio
Data
Optical
Racks
Optional



Visit the
product page:



Features

- Extend serial and GPI connections up to 10km*
- Supports serial RS232 or RS422 or RS485
- 2 x GPI connections
- Singlemode fiber 1310nm up to 10km* (6.2 miles)
- Multimode fiber 850nm up to 550m* (1,804 feet)
- LC/PC duplex fiber connections
- Switchable RX/TX crossover
- Automatic or manual data direction
- Switchable end of line termination
- 'Plug and Play' - No PC software drivers needed
- Supports all serial protocols (standard or proprietary)

Description

The ODT 1510 is a multi-function module which (when used with another ODT 1510 in the remote location) will extend the reach of serial RS232, RS422 or RS485 as well as two GPI (general purpose I/O) up to 10km (6.2 miles) over fiber.

A single RJ45 electrical serial connection can be configured for RS232, RS422 or RS485 serial standards. A separate RJ45 connector is provided for two electrical GPI inputs and outputs. Serial communications and GPI are transmitted and extended over the same fiber link.

The ODT 1510 is completely agnostic to the serial protocol used, and supports all standard protocols and proprietary protocols at data rates from 300 to 460K Baud (*auto sensing and auto adjusting*).

The integrated dip switch provides precise control over the serial mode of operation with selections for the *serial standard*, *serial termination*, *RX/TX crossover* and *RS422/485 data direction (automatic or manual)*. Data activity LEDs are provided for the serial port and the GPI port under the respective RJ45 connectors.

The ODT 1510 also supports mixing and matching of serial standards. For example: the transmitting module can have a RS232 input, and the receiving module can be set for RS422 output.

Technical Specifications

Serial I/O	EIA/ETA RS232C / RS422 / RS485 (selectable) - RJ-45 Connector
	Baud rate - Auto sense and auto adjust from 300 to 460k
Settings	<ul style="list-style-type: none"> • Select RS232 / RS422 / RS485 modes • Select serial termination (for end of line) • RX/TX crossover to flip the RX and TX if needed • Set RS422/485 data direction to automatic or manual if needed
	LED status indicators (under RJ45 connector) Serial TX activity + Serial RX activity
	RS422/485 max. number of electrical nodes = 25
	ESD protection for up to 26kV
GPI I/O	2x inputs, 2x outputs - RJ45 Connector
Inputs	<ul style="list-style-type: none"> • External passive closure between pins (short) to trigger • Max switching frequency 25Hz (50 operations / second) • Input insulation 3.75kV
Outputs	<ul style="list-style-type: none"> • Internal contact closure (relay) • Max switching frequency 25Hz (50 operations / second) • Max switching power 220V DC / 0.25A or 250V AC / 0.25A • Output insulation 3.75kV
	LED status indicators (under RJ45 connector) GPI Input 1 activity / GPI Input 2 activity GPI Output 1 activity / GPI Output 2 activity
Fiber Optic	1 x Fiber output (TX) and 1x Fiber input (RX) - LC/PC Connector
	Singlemode Version: ODT 1510 TX wavelength 1310nm, power -3dBm RX input range 1260nm to 1620nm, sensitivity -3dBm to -21dBm Max. Distance 10km* (6.2 miles)
	Multimode Version: ODT 1510 MM TX wavelength 850nm, power -2dBm to -7dBm RX input 850nm, sensitivity 0dBm to -15dBm Max. Distance 550m* (1804 feet)
	RX and TX activity LEDs on side of module next to fiber I/O
Power	+12V DC @ 2.0W nominal - (supports 7 - 15V DC input range)
Physical	Size (incl. connectors): 120mm x 42mm x 22mm (4.73" x 1.65" x 0.86") Weight: 125g (4.4oz)
Ambient	5 - 40°C (41 - 104°F) 90% Humidity (non condensing)
Model #	ODT 1510 (Singlemode) EAN# 4250479315136 ODT 1510 MM (Multimode) EAN# 4250479321137
Includes	Module, AC power supply, SFP, mini USB cable, Ethernet cable

*Distance is an approximation. Actual distances achieved can be longer or shorter depending on the type of cable. Determine link losses and perform optical budget calculations to ensure correct operation.

OBD 1510 D

RS232/422/485 Serial and GPI Bidirectional Fiber Transceiver

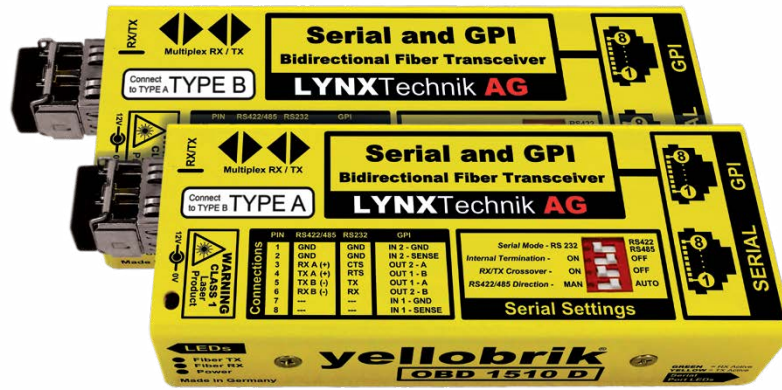

Visit the product page:



Features

- Bidirectional send and receive serial and GPI connections up to 10km
- Supports serial RS232, RS422 or RS485 @ 300 - 460K Baud
- Auto sensing and auto adjusting
- 2 x GPI connections
- Singlemode duplex LC/PC fiber up to 10km (6.2 miles)
- Switchable RX/TX crossover
- Automatic or manual data direction
- Switchable end of line termination
- Supports all serial protocols (standard or proprietary)

Description

The OBD 1510 D is a pair of modules that helps extend the reach of serial RS232, RS422 or RS485 connections to up 10km* (6.2 miles) over a single bidirectional fiber link (WDM).

Serial connection is made with a single RJ45 electrical cable. A separate RJ45 connector is provided for electrical GPI inputs and outputs. Serial communications and GPI are transmitted and extended over the same fiber link. The OBD 1510 D supports all standard and proprietary protocols at data rates from 300 to 460K Baud (auto sensing and auto adjusting). Mixing and matching of serial standards is also supported.

The integrated dip switch provides control over the serial mode of operation with selections for the serial standard, serial termination, RX/TX crossover and RS422/485 data direction (automatic or manual).

Note: This system used WDM optical multiplexing and should only be used in point to point applications. This solution cannot be integrated into a CWDM multiplexed system.

Technical Specifications

Serial I/O	EIA/ETA RS232C / RS422 / RS485 (selectable) - RJ45 connector Baud rate - Auto sense and auto adjust from 300 to 460k Serial setting dip switch provides settings for: <ul style="list-style-type: none"> • Select RS232 / RS422 / RS485 modes • Select serial termination (for end of line) • RX/TX crossover to flip the RX and TX if needed • Set RS422/485 data direction to automatic or manual if needed LED status indicators (under RJ45 connector) Serial TX activity + Serial RX activity RS422/485 Max number of electrical nodes = 25 ESD protection for up to 26kV
GPI I/O	2x inputs + 2x outputs - RJ45 connector GPI Inputs: <ul style="list-style-type: none"> • External passive closure between pins (short) to trigger • Max input switching frequency 25Hz (50 operations / second) • Input insulation 3.75kV GPI Outputs: <ul style="list-style-type: none"> • Internal contact closure (relay) • Max switching frequency 25Hz (50 operations / second) • Max switching power 220V DC / 0.25A or 250VAC / 0.25A • Output insulation 3.75kV LED status indicators (below RJ45 connector) GPI Input 1 activity / GPI Input 2 activity GPI Output 1 activity / GPI Output 2 activity
Fiber Optic	1 x Fiber optic I/O port (bidirection) Simplex (singlemode) using LC/PC connection WDM using 1310nm and 1550nm wavelengths (Optical budget: 18dB) Max* distance approx. 10km (6.2 miles) RX and TX activity LEDs on side of module next to fiber I/O
Power (per module)	+12V DC @ 2.0W nominal - (supports 7 - 15V DC input range)
Physical (per module)	Size (incl. connectors): 120mm x 42mm x 22mm (4.73" x 1.65" x 0.86") Weight: 125g (4.4oz)
Ambient	5 - 40°C (41 - 104°F) 90% Humidity (non condensing)
Model #	OBD 1510 D - (EAN# 4250479319103)
Includes	2x modules (Type A and B), 2x power supplies, 2x SFP, 2x USB cable

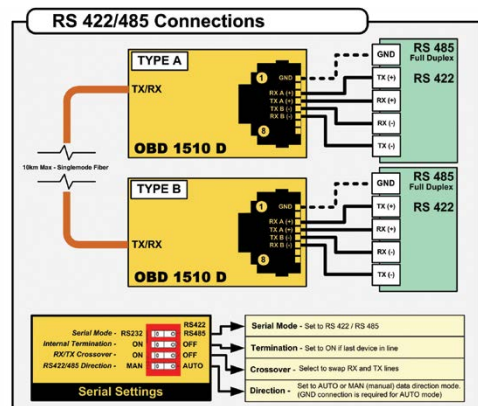
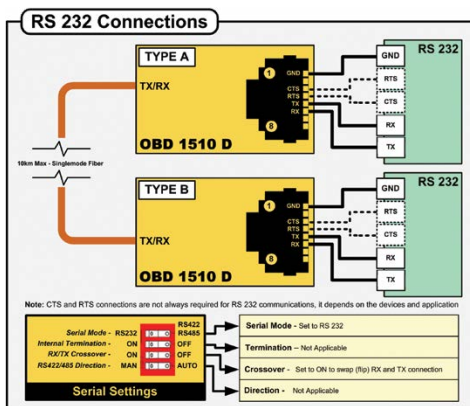

*Distance is an approximation. Actual distances achieved can be longer or shorter depending on the type of cable. Determine link losses and perform optical budget calculations to ensure correct operation.

ODT 1540

Serial and GPI Fiber Transceiver [CWDM]



Visit the product page:



Installed optional SFP shown is not included

Features

- Extend serial and GPI connections up to 40km*
- Supports serial RS232, RS422, and RS485
- 2 x GPI connections
- Select from 18 fiber wavelengths (CWDM)
- LC/PC duplex fiber connections
- Switchable RX/TX crossover
- Automatic or manual data direction
- Switchable end of line termination
- 'Plug and Play' - No PC software drivers needed
- Supports all serial protocols (standard or proprietary)
- 300 - 460K Baud (auto sensing and auto adjusting)

Description

The ODT 1540 is a multi-function CWDM compatible module which (when used with another ODT 1540 in the remote location) will extend the reach of serial RS232, RS422 or RS485 as well as two GPI (general purpose I/O) up to 40km* over fiber. 18 wavelength sections are provided for CWDM use.

A single RJ45 electrical serial connection can be configured for RS232, RS422 or RS485 serial standards. A separate RJ45 connector is provided for two electrical GPI inputs and outputs. Serial communications and GPI are transmitted and extended over the same fiber link.

The ODT 1540 is completely agnostic to the serial protocol used, and supports all standard protocols and proprietary protocols at data rates from 300 to 460K Baud (auto sensing and auto adjusting).

The integrated dip switch provides precise control over the serial mode of operation with selections for the serial standard, serial termination, RX/TX crossover and RS422/485 data direction (automatic or manual). Data activity LEDs are provided for the serial port and the GPI port under the respective RJ45 connectors.

The ODT 1540 also supports mixing and matching of serial standards. For example: the transmitting module can have a RS232 input, and the receiving module can be set for RS422 output.

SFP Module Options

Base price **DOES NOT INCLUDE** the fiber transmitter SFP. Please specify the required SFP from the option list.

Option #	Wavelength	TX Power	RX Sensitivity	Distance*
OH-TR-58-XXXX-LC	1270 - 1610nm	0 to +5dBm	-23dBm	80km* (49.7 miles)
OH-TR-54-XXXX-LC	1270 - 1610nm	-5 to 0dBm	-23dBm	40km* (24.6 miles)

Technical Specifications

Serial I/O	EIA/ETA RS232C / RS422 / RS485 (selectable) - RJ45 Connector Baud rate - Auto sense and auto adjust from 300 to 460k
Settings	Serial setting dip switch provides settings for: <ul style="list-style-type: none"> • Select RS232 / RS422 / RS485 modes • Select serial termination (for end of line) • RX/TX crossover to flip the RX and TX if needed • Set RS422/485 data direction to automatic or manual if needed LED status indicators (under RJ45 connector) Serial TX activity + Serial RX activity RS422/485 Max number of electrical nodes = 25 ESD protection for up to 26kV
GPI I/O	2x inputs + 2x outputs - RJ 45 connector
Inputs	GPI Inputs: <ul style="list-style-type: none"> • External passive closure between pins (short) to trigger • Max input switching frequency 25Hz (50 operations / second) • Input insulation 3.75kV
Outputs	GPI Outputs: <ul style="list-style-type: none"> • Internal contact closure (relay) • Max switching frequency 25Hz (50 operations / second) • Max switching power 220V DC / 0.25A or 250V AC / 0.25A • Output insulation 3.75kV LED status indicators (under RJ45 connector) GPI Input 1 activity / GPI Input 2 activity GPI Output 1 activity / GPI Output 2 activity
Fiber Optic	1x input, 1x output - Duplex (Singlemode) LC/PC connector RX and TX activity LEDs on side of module next to fiber I/O Max. distance approx. 40km* (24.8 miles - Singlemode)
Power	+12V DC @ 1.6W nominal without SFP +12V DC @ 2.1W nominal with SFP (supports 7 - 15V DC input range)
Physical	Size: 120mm x 42mm x 22mm (4.73" x 1.65" x 0.86") including connectors Weight: 125g (4.4oz)
Ambient	5 - 40°C (41 - 104°F) 90% Humidity (non condensing)
Model #	ODT 1540 EAN# 4250479315433
Includes	Module, AC power supply

*Distance is an approximation. Actual distances achieved can be longer or shorter depending on the type of cable. Determine link losses and perform optical budget calculations to ensure correct operation.

OTR 1210

MADI Fiber Transceiver



Features

- MADI Optical to MADI Coaxial converter
- Supports up to 64 channels of audio (IN and OUT)
- Real time conversion with no degradation of signal quality
- Distance up to 10km* (6.2 miles) using Singlemode fiber
- Distance up to 550m* (1804 feet) using Multimode fiber
- Duplex LC single- or multimode optical connections



Description

The OTR 1210 is a MADI fiber transmitter and receiver combined in a single package. The module is designed to convert up to 64 audio channels bidirectionally (64 IN & 64 OUT) between MADI Optical and MADI Coaxial (electrical) formats. Conversion is real time [no latency] and does not degrade the signal quality.

distances. When paired with another OTR 1210 at the receiving end (using two fiber links) you have a cost-effective, zero latency MADI extender system. Two versions are available. The singlemode fiber version will transport MADI over distances up to 10km*, and the multimode version up to 550m*.

The OTR 1210 is compact and cost-effective solution to extend the reach of MADI audio over long

Technical Specifications

Coax Input	1 x 75 Ohm BNC connector			
	Supported standards: AES10-2008			
	Automatic Cable EQ*:	250m	Belden 1694A	
Coax Output	1 x 75 Ohm BNC connector			
	Amplitude:	750mV (Peak to Peak)		
	Automatic Cable EQ*:	250m	Belden 1694A	
Fiber Optic	1 x fiber optic input 1 x fiber optic output			
	Duplex connection using LC/PC Connections			
	TX active and RX active LEDs on side of module			
Singlemode OTR 1210	Transmitter	Wavelength	1310nm	
		Optical Power	-9dBm to -3dBm	
	Receiver	Wavelength	1260nm to 1620nm	
		Sensitivity	-23 dBm (max)	
		Max. Distance*	10km (6.2 miles)	
Multimode MM-850	Transmitter	Wavelength	850nm	
		Optical Power	-7dBm to -2dBm	
	Receiver	Wavelength	850nm	
		Sensitivity	-15dBm (min)	
		Max. Distance*	2km (1.2 miles)	
Multimode MM-1310	Transmitter	Wavelength	1310nm	
		Optical Power	-20dBm to -14dBm	
	Receiver	Wavelength	1270nm to 1620nm	
		Sensitivity	-30dBm	
		Max. Distance*	2km (1.2 miles)	
Power	+12V DC @ 1.7W nominal - (supports 7 - 24V DC input range)			
	Power LED on side of module			
Physical	Size (incl. connectors): 140mm x 42mm x 22mm (5.51" x 1.65" x 0.86")			
	Weight	125g (4.4oz)		
Ambient	5 - 40°C (41 - 104°F) 90% Humidity (non condensing)			
Model #	OTR 1210	EAN# 4250479324671		
	OTR 1210 MM-850	EAN# 4250479324688		
	OTR 1210 MM-1310	EAN# 4250479326224		
Includes	Module, SFP Module, AC power supply			

OBD 1210

MADI Bidirectional Fiber Transceiver



Features

- Bidirectional MADI send and receive over single fiber link
- MADI Optical to MADI Coaxial converters
- Supports up to 64 channels of audio (IN and OUT)
- Closed loop WDM fiber system
- Distances up to 10km* (6.2 miles) over SMF fiber
- Simplex LC singlemode optical connection

Description

The OBD 1210 is a matched pair of compact MADI fiber transceivers designed to extend the reach of MADI signals over long distances (up to 10km)

bidirectional fiber link between the modules. (singlemode fiber)

The modules are designed to convert up to 64 audio channels bidirectionally (64 IN & 64 OUT) between MADI Optical and MADI Coaxial (electrical) formats.

The OBD 1210 solution is supplied as a complete kit which includes two matched modules, two power supplies and a transport case.

Conversion is real time [no latency], does not degrade the signal quality and only requires a single

Note: This system used WDM optical multiplexing and should only be used in point to point applications. This solution cannot be integrated into a CWDM multiplexed system.

Technical Specifications

Coax Input	1 x 75 Ohm BNC connector		
	Supported standards: AES10-2008		
	Automatic Cable EQ*:	250m	Belden 1694A
Coax Output	1 x 75 Ohm BNC connector		
	Amplitude	750mV (Peak to Peak)	
	Automatic Cable EQ*:	250m	Belden 1694A
Fiber Optics	1 x Bidirectional fiber connection (LC/PC Connection)		
	Wavelength:	Type A	TX: 1310nm / RX: 1550nm (WDM)
		Type B	TX: 1550nm / RX: 1310nm (WDM)
	Optical power:	Type A / B	-8dBm to -3dBm
	RX Sensitivity	Type A / B	-16dBm
	TX & RX active LED on side of module		
	Max. distance*	max. 10km* (6.2 miles)	
Power (per module)	+12V DC @ 2.7W nominal - (supports 7 - 24V DC input range)		
	Power LED on side of module		
Physical (per module)	Size	140mm x 42mm x 22mm	
	(incl. connectors)	(5.51" x 1.65" x 0.86")	
	Weight	125g (4.4oz)	
Ambient	5 - 40°C (41 - 104°F) 90% Humidity (non condensing)		
Model #	OBD 1210	EAN# 4250479324640	
Includes	2x Modules, 2x SFP Modules, 2x AC power supply		

*Distance is an approximation. Actual distances achieved can be longer or shorter depending on the type of cable. Determine link losses and perform optical budget calculations to ensure correct operation.

OTR 1240

MADI/Fiber Transceiver [CWDM]



Visit the product page:



Video

Audio

Data

Optical

Racks

Optional

Features

- MADI Optical to MADI Coaxial converter
- Supports up to 64 channels of audio (IN and OUT)
- Real time conversion with no degradation of signal quality
- Distance up to 40km* (24.8 miles) over fiber
- 18 CWDM wavelength selections (ITU-T G.694.2)
- Duplex LC singlemode optical connections

Description

The OTR 1240 is a MADI fiber transmitter and receiver combined in a single package. The module is designed to convert up to 64 audio channels bidirectionally (64 IN & 64 OUT) between MADI Optical and MADI Coaxial (electrical) formats. Conversion is real time [no latency] and does not degrade the signal quality.

The OTR 1240 is compact and cost-effective solution to extend the reach of MADI audio over long distances. When paired with another OTR 1240 at the receiving end (using two fiber links) you have a cost-effective, zero latency MADI extender system for distances up to 40km*.

18 selectable CWDM wavelengths are provided to enable the module to be used in a multiplexed CWDM environment.

Note: This yellobrik **DOES NOT INCLUDE** the fiber SFP module. Please specify the required SFP option from the option list.

Technical Specifications

Coax Input	1 x 75 Ohm BNC connector		
	Supported standards: AES10-2008		
	Cable length	250m (Belden 1694A)	
Coax Output	1 x 75 Ohm BNC connector		
	Amplitude:	750mV P/P	
	Cable length	250m (Belden 1694A)	
Fiber Optic	1 x fiber optic input 1 x fiber optic output		
	Duplex (singlemode) connection using LC/PC Connections		
	Transmitter:	Wavelength	See CWDM Wavelength Options
		Optical Power	See CWDM Wavelength Options
	Receiver	Wavelength	1260nm to 1620nm
		Sensitivity	See CWDM Wavelength Options
	Max. Distance*	40km (24.8 miles)	
TX & RX active LEDs on side of module			
Power	+12V DC @ 2.6W nominal - (supports 7 - 24V DC input range)		
Power LED on side of module			
Physical	Size (incl. connectors)	140mm x 42mm x 22mm (5.51" x 1.65" x 0.86")	
	Weight	125g (4.4oz)	
	Ambient	5 - 40°C (41 - 104°F) 90% Humidity (non condensing)	
Model #	OTR 1240	EAN# 4250479324695	
Includes	Module, AC power supply		

SFP Module Options

Base price **DOES NOT INCLUDE** the fiber transmitter SFP. Please specify the required SFP from the option list.

Option #	Wavelength	TX Power	RX Sensitivity	Distance*
OH-TR-58-XXXX-LC	1270 - 1610nm	0 to +5dBm	-23dBm	80km* (49.7 miles)
OH-TR-54-XXXX-LC	1270 - 1610nm	-5 to 0dBm	-23dBm	40km* (24.6 miles)

DVD 1417

12G 1►7 SDI Reclocking Distribution Amplifier



Features

- 1 input and 7 outputs
- Suitable for SDI video up to 12Gbit/s (4k/UHD)
- Supports SD SDI, HD SDI, 3G SDI, 6G SDI and 12G SDI
- Reclocking
- Auto-detect input format

Description

The DVD 1417 is a compact SDI distribution amplifier, which is suitable for all SMPTE standard SDI signals from 270Mbit/s to 4k UHD (12 Gbit/s). The SDI input format is auto-detected and all outputs are reclocked.

Supported Standards: SMPTE 259M (270Mbit/s), SMPTE 292M (1.5Gbit/s), SMPTE 424M (3Gbit/s), SMPTE 2081 (6Gbit/s) and SMPTE 2082 (12Gbit/s)

Technical Specifications

Input	1 x SDI; 75 Ohm BNC connector SMPTE 424M, SMPTE 292M, SMPTE 259M, SMPTE 2081, SMPTE 2082 Multi-standard operation from 270Mbit/s to 12Gbit/s; reclocking Input present LED indication Electrical Return Loss: >15dB from 5MHz to 1.5GHz, >10dB from 1.5GHz to 3GHz, >7dB from 3GHz to 6GHz; >4dB from 6GHz to 12GHz Automatic Cable EQ* 400m @ 270Mbit/s, 200m @ 1.5Gbit/s, 150m @ 3Gbit/s (Belden 1694A cable) 90m @ 6Gbit/s; 80m @ 12Gbit/s (Belden 4794R cable)
Outputs	7 x multi-rate reclocked SDI outputs ; 75 Ohm BNC connectors SMPTE 424M, SMPTE 292M, SMPTE 259M, SMPTE 2081, SMPTE 2082 Electrical Return Loss: >15dB from 5MHz to 1.5GHz, >10dB from 1.5GHz to 3GHz, >7dB from 3GHz to 6GHz; >4dB from 6GHz to 12GHz Alignment Jitter < 0.2 UI @ 270Mbit/s, < 0.2 UI @ 1.5Gbit/s, < 0.3 UI @ 3Gbit/s, 6Gbit/s, 12Gbit/s Timing Jitter < 0.2 UI @ 270Mbit/s, < 1.0 UI @ 1.5Gbit/s, < 2.0 UI @ 3Gbit/s, 6Gbit/s, 12Gbit/s
Power	+12V DC @ 2.7W nominal - (supports 7 - 16V DC input range)
Physical	Size (incl. connectors): 138 x 90 x 22mm (5.43" x 3.54" x 0.86") Weight: 240g (8.46oz)
Ambient	5 - 40°C (41 - 104°F) 90% Humidity (non condensing)
Model #	DVD 1417 - (EAN# 4250479325210)
Includes	Module, AC power supply

DVD 1423

12G Dual 1►3 SDI Reclocking Distribution Amplifier



Features

- Two independent inputs
- Three outputs per channel
- Suitable for SDI video up to 12Gbit/s (4k/UHD)
- Supports SD SDI, HD SDI, 3G SDI, 6G SDI and 12G SDI
- Reclocking
- Auto-detect input format

Description

The DVD 1423 is a compact SDI distribution amplifier, which is suitable for all SMPTE standard SDI signals from 270Mbit/s to 4k UHD (12 Gbit/s). The SDI input formats are auto-detected and all outputs are reclocked.

SMPTE 259M (270Mbit/s), SMPTE 292M (1.5Gbit/s), SMPTE 424M (3Gbit/s), SMPTE 2081 (6Gbit/s) and SMPTE 2082 (12Gbit/s)

Each channel is 100% independent and can process different SDI formats if required.

Supported Standards:

Technical Specifications

Input	2 x SDI; 75 Ohm BNC connector SMPTE 424M, SMPTE 292M, SMPTE 259M, SMPTE 2081, SMPTE 2082 Multi-standard operation from 270Mbit/s to 12Gbit/s; reclocking Input present LED indication Electrical Return Loss: >15dB from 5MHz to 1.5GHz, >10dB from 1.5GHz to 3GHz, >7dB from 3GHz to 6GHz; >4dB from 6GHz to 12GHz Automatic Cable EQ* 400m @ 270Mbit/s, 200m @ 1.5Gbit/s, 150m @ 3Gbit/s (Belden 1694 cable) 90m @ 6Gbit/s; 80m @ 12Gbit/s (Belden 4794R cable)
Outputs	3 x multi-rate reclocked SDI outputs per channel ; 75 Ohm BNC connectors SMPTE 424M, SMPTE 292M, SMPTE 259M, SMPTE 2081, SMPTE 2082 Electrical Return Loss: >15dB from 5MHz to 1.5GHz, >10dB from 1.5GHz to 3GHz, >7dB from 3GHz to 6GHz; >4dB from 6GHz to 12GHz Alignment Jitter < 0.2 UI @ 270Mbit/s, < 0.2 UI @ 1.5Gbit/s, < 0.3 UI @ 3Gbit/s, 6Gbit/s; 12Gbit/s Timing Jitter < 0.2 UI @ 270Mbit/s, < 1.0 UI @ 1.5Gbit/s, < 2.0 UI @ 3Gbit/s, 6Gbit/s; 12Gbit/s
Power	+12V DC @ 3.3W nominal - (supports 7 - 16V DC input range)
Physical	Size (incl. connectors): 138 x 90 x 22mm (5.43" x 3.54" x 0.86") Weight: 240g (8.46oz)
Ambient	5 - 40°C (41 - 104°F) 90% Humidity (non condensing)
Model #	DVD 1423 - (EAN# 4250479325227)
Includes	Module, AC power supply

*Distance is an approximation. Actual distances achieved can be longer or shorter depending on the type of cable. Determine link losses and perform optical budget calculations to ensure correct operation.

DVD 1817

3G 1►7 SDI Reclocking Distribution Amplifier



Features

- 1 input and 7 outputs
- Suitable for SDI video up to 3Gbit/s (1080p60)
- Level A and Level B support (all formats) and DVB-ASI
- Reclocking
- Auto-detect input format
- Input present LED indication

Description

The DVD 1817 is a compact general purpose reclocking SDI distribution amplifier suitable for any level A or Level B SDI video signal up to 3Gbit (1080p60) including DVB-ASI signals.

Supported Standards: SMPTE 424M (3Gbit/s), SMPTE 292M (1.5Gbit/s) and SMPTE 259M (270Mbit/s) standards are supported.

Technical Specifications

Input	1 x SDI 75 Ohm BNC connector SMPTE 424M, SMPTE 292M, SMPTE 259M, DVB-ASI Multi-standard operation from 270Mbit/s to 3Gbit/s Multi-rate reclocking Input present LED indication Electrical Return Loss: >15dB from 5MHz to 1.5GHz, >10dB from 1.5GHz to 3GHz Automatic Cable EQ* (Belden 1694A cable) 320m @ 270Mbit/s, 160m @ 1.5Gbit/s, 120m @ 3Gbit/s
Outputs	7 x multi-rate reclocked SDI outputs SMPTE 424M, SMPTE 292M, SMPTE 259M, DVB-ASI 75 Ohm BNC connectors Electrical Return Loss: >15dB from 5MHz to 1.5GHz, >10dB from 1.5GHz to 3GHz Alignment Jitter < 0.2 UI @ 270Mbit/s, < 0.2 UI @ 1.5Gbit/s, < 0.3 UI @ 3Gbit/s Timing Jitter < 0.2 UI @ 270Mbit/s, < 1.0 UI @ 1.5Gbit/s, < 2.0 UI @ 3Gbit/s
Power	+12V DC @ 1.3W nominal - (supports 7 - 16V DC input range)
Physical	Size (incl. connectors): 138mm x 90mm x 22mm (5.43" x 3.54" x 0.86") Weight: 240g (8.46oz)
Ambient	5 - 40°C (41 - 104°F) 90% Humidity (non condensing)
Model #	DVD 1817 - (EAN# 4250479359628)
Includes	Module, AC power supply

DVD 1823

3G Dual 1►3 SDI Reclocking Distribution Amplifier



Features

- Dual channel
- 1 input and 3 outputs per channel
- Suitable for SDI video up to 3Gbit/s (1080p60)
- Level A and Level B support (all formats) and DVB-ASI
- Reclocking
- Auto-detect input format

Description

The DVD 1823 is a compact general purpose, dual channel reclocking SDI distribution amplifier suitable for any level A or Level B SDI video signal up to 3Gbit/s (1080p60) including DVB-ASI signals.

Each channel is 100% independent and can process different SDI formats if required.

Supported Standards:
SMPTE 424M (3Gbit/s), SMPTE 292M (1.5Gbit/s)

and SMPTE 259M (270Mbit/s)

Technical Specifications

Inputs	2 x SDI - 75 Ohm BNC connector SMPTE 424M, SMPTE 292M, SMPTE 259M, DVB-ASI Multi-standard operation from 270Mbit/s to 3Gbit/s Multi-rate reclocking Input present LED indication for each channel Electrical Return Loss: >15dB from 5MHz to 1.5GHz, >10dB from 1.5GHz to 3GHz Automatic Cable EQ* (Belden 1694A cable) 320m @ 270Mbit/s, 160m @ 1.5Gbit/s, 120m @ 3Gbit/s
Outputs	3 x multi-rate reclocked SDI outputs per channel SMPTE 424M, SMPTE 292M, SMPTE 259M, DVB-ASI 75 Ohm BNC connectors Electrical Return Loss: >15dB from 5MHz to 1.5GHz, >10dB from 1.5GHz to 3GHz Alignment Jitter < 0.2 UI @ 270Mbit/s, < 0.2 UI @ 1.5Gbit/s, < 0.3 UI @ 3Gbit/s Timing Jitter < 0.2 UI @ 270Mbit/s, < 1.0 UI @ 1.5Gbit/s, < 2.0 UI @ 3Gbit/s
Power	+12V DC @ 2.1W nominal (supports 7 - 16V DC input range)
Physical	Size (incl. connectors): 138 x 90 x 22mm (5.4" x 3.5" x 0.8") Weight: 240g (8.46oz)
Ambient	5 - 40°C (41 - 104°F) 90% Humidity (non condensing)
Model #	DVD 1823 - (EAN# 4250479359635)
Includes	Module, AC power supply

*Distance is an approximation. Actual distances achieved can be longer or shorter depending on the type of cable. Determine link losses and perform optical budget calculations to ensure correct operation.

DVA 1714**Wide Band 1►4 Analog Video/Sync Distribution Amplifier**

Visit the
product page:

**Features**

- 1 input and 4 outputs
- Wide band - 30MHz
- Adjustable gain and EQ
- Input Clamp
- Input present LED indication
- Suitable for analog SDTV/HDTV video or Sync signals

Description

The DVA 1714 is a compact general purpose wide band analog distribution amplifier suitable for analog SDTV and HDTV video signals.

The module can also be used for analog SDTV Bi-level sync pulses, black reference and analog HDTV Tri-level sync pulses.

Features include an Input clamp with user adjustable gain and cable EQ ualization.

LED indicators are provided for signal presence and power.

Technical Specifications

Input	1 x 75 Ohm BNC connector
	Compatible Input Sources SDTV Composite video (NTSC/PAL) SDTV Component Analog Video HDTV Component Analog Video SDTV Bi-level sync (or black burst) HDTV Tri-Level Sync
	Return loss > 31dB to 30MHz
	Input Gain adjustment range +/- 2.5dB
	Input Cable EQ*ualization Adjustment 0 - 8dB
	Input clamp
	Input presence detection (LED)
Outputs	4 x Analog Video / Sync Outputs
	75 Ohm BNC connectors
	Return loss >22dB to 30MHz
Performance	Frequency Response: -3dB @ 30MHz (EQ min) -3dB @ 37MHz (EQ max) +/- 0.1dB to 10MHz
	Signal to noise >60dB (RMS)
Power	+12V DC @ 1.3W nominal - (supports 8 - 24V DC input range)
Physical	Size (incl. connectors): 138mm x 90mm x 22mm (5.43" x 3.54" x 0.86") Weight: 220g (7.8oz)
Ambient	5 - 40°C (41 - 104°F) 90% Humidity (non condensing)
Model#	DVA 1714 - (EAN# 4250479321182)
Includes	Module, AC Power supply

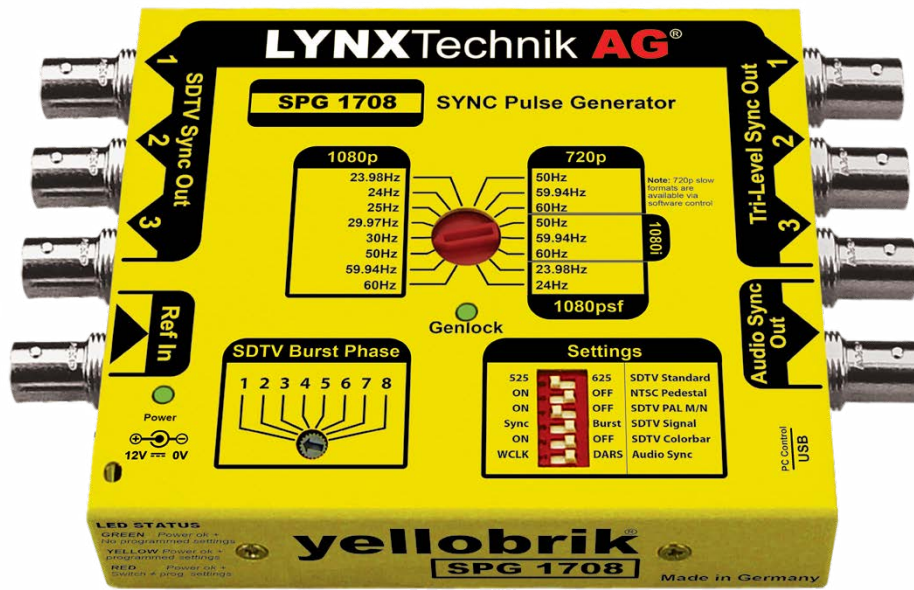

Visit the product page:



Features

- Supports all regular analog Tri- and Bi-Level Sync standards
- Simultaneous HD/Tri-Level and SD/Bi-Level sync outputs
- 3 x HD/Tri-Level and 3 x SD/Bi-Level sync outputs
- Genlock with cross lock to any sync standard
- "Color Bars", "Black Burst" or "Sync Only" for SD
- NTSC, PAL or PAL M/N for Bi-Level sync outputs
- Burst phase adjustment for NTSC and PAL sync
- Audio Sync output 48kHz Word Clock or DARS
- yelloGUI and LynxCentraal compatible to access additional internal settings

Description

The SPG 1708 is a compact, versatile analog sync pulse generator with genlock providing Tri-/ Bi-Level video sync and audio signals. The module offers three Tri-Level sync outputs, three Bi-Level sync outputs, and a separate Audio Sync output, with 48kHz Word Clock or Digital Audio Sync Signal (DARS) capabilities.

The sync generator has an accuracy of 2ppm, is robust and temperature stabilized. The flexible genlock capability allows the module to genlock to any SD, HD, and 3G reference input, with full cross-lock functionality and timing lock, even across unmatched standards.

Bi-Level and Tri-Level sync outputs and audio sync signals are all **frequency locked** to the reference, regardless of the selected sync standard for the outputs. Output signals are **timing locked** if they are in the same frame rate group as the reference. Additionally, a delay in units of output **line and pixel** can be applied when remote controlling the SPG 1708 via yelloGUI or LynxCentraal.

Frame Rate Groups

23.98Hz	24Hz	25Hz & 50Hz	29.97Hz & 59.94Hz	30Hz & 60Hz
---------	------	-------------	-------------------	-------------

Available sync formats for Bi-Level Sync are NTSC, PAL, or PAL M/N. In addition it can output Color Bars, Black Burst, or just the Sync signal with selectable 7.5 IRE pedestal for NTSC standards with adjustable burst phase in 8 increments. The Tri-level sync outputs can be set to any of the available HD/3G standards.

User controls are located on the top side of the module, clearly labeled, and easily accessible. When remote controlling the device via USB, more options and settings are available with yelloGUI and LynxCentraal.

Technical Specifications

HD Sync	3 x Tri-level Sync outputs
	1080i 50Hz /59.94Hz /60Hz
	1080p 23.98Hz /24Hz /25Hz /29.97Hz /30Hz /50Hz /59.94Hz /60Hz
	720p 23.98Hz /24Hz /25Hz /29.97Hz /30Hz /50Hz /59.94Hz /60Hz
	1080psf 23.98Hz /24Hz
	SMPTE 274M, SMPTE 296M
	Selectable via integrated 16 position rotary switch
	Return Loss: >40dB up to 5MHz
	SNR > 75dB
SD Sync	3 x Bi-level Sync outputs
	NTSC, PAL, PAL M/N
	SMPTE 170M, ITU-R BT 470.6
	Selectable: 75% color bars / black burst / sync only
	NTSC 7.5 IRE pedestal ON/OFF
	Adjustable burst phase in 8 increments
	Return Loss: >40dB up to 5MHz
	SNR > 75dB
Ref Input	Bi-level or tri-level analog sync
	Cross lock compatible to 525 and 625 SD sync and all HD sync standards
	SMPTE 274M, SMPTE 296M
Audio Sync	48kHz Word Clock or DARS
	48kHz Word Clock: 0 - 5.0V
	DARS: SMPTE 276M unbalanced AES (24-bits) - Grade 2
Accuracy	2 ppm
Power	+12V DC @ 2.4W nominal - (supports 7 - 17V DC input range)
USB	Mini "Type B" connection for firmware upgrades and remote control
Physical	Size (incl. connectors): 140mm x 90mm x 22mm (5.51" x 3.34" x 0.86") Weight: 300g (10.6oz)
Ambience	5 - 40°C (41 - 104°F) 90% Humidity (non condensing)
Model #	SPG 1708 - (EAN# 4250479328655)
Includes	Module, AC power supply

OSW 1022

2x2 Optical Switch

compatible with

LYNX | Centraal™

yelloGUI



Visit the product page:



Features

- Compact 1 slot yellobrik module
- Two optical connection paths: State 1 and State 2
- Non-latching and latching mode
- 2 x GPI for path selections
- 2 x GPO for connection path monitoring
- 4 x dip switches for local control
- 2 x LEDs to display connection path status
- 1 x LED to display power status
- 1 x mini USB for PC control and configuration via yelloGUI and LynxCentraal
- Singlemode fiber connection with LC connector

Description

The OSW 1022 is an optical 2x2 switch that provides connection paths between two pairs of fiber optic. The compact OSW 1022 switch is suitable for a wide range of applications such as fibre line emergency switchover, route diversity, optical networking system protection, and reconfiguration.

It allows the selection of passive optical paths via GPI control, or local dip switches, or PC/Mac. The GPIs and GPOs provide selection and monitoring of connection paths State 1 & State 2.

It also provides latching and non-latching mode. In the latching mode, the optical switch maintains the current optical connection path (state) and does not change on power failure. In the non-latching mode, the optical switch switches to State 1 connection path upon power failure. When the power is restored, the switch will revert to the connection path set by the dip switch or to the state set by the GUI.

Technical Specifications

Fiber Optic Cable Type	Singlemode																		
Fiber Connector	LC/PC																		
Optical Wavelength	1240 ~ 1640nm																		
Insertion loss	≤1.0 (Typ 0.4) dB																		
Return Loss	≥ 50 (Typ 55) dB																		
Switch Speed	≤1, (Typ 0.5) ms																		
Repeatability	≤0.002 dB																		
USB	1x mini USB Type B																		
GPI	Connector: RJ45 with 2x GPI and 2x GPO																		
	<table border="1"> <tr> <th>Pin</th> <th>1</th> <th>2</th> <th>3</th> <th>4</th> <th>5</th> <th>6</th> <th>7</th> <th>8</th> </tr> <tr> <th>GPIO</th> <td>GPO 2A</td> <td>GPO 2B</td> <td>GND</td> <td>GPI 1</td> <td>GND</td> <td>GPI 2</td> <td>GPO 1A</td> <td>GPO 1B</td> </tr> </table>	Pin	1	2	3	4	5	6	7	8	GPIO	GPO 2A	GPO 2B	GND	GPI 1	GND	GPI 2	GPO 1A	GPO 1B
Pin	1	2	3	4	5	6	7	8											
GPIO	GPO 2A	GPO 2B	GND	GPI 1	GND	GPI 2	GPO 1A	GPO 1B											
Power	+12V DC @ 1 W nominal - (supports 7 - 24V DC input range)																		
Physical	Size: 108mm x 90mm x 22mm (4.25" x 3.54" x 0.86") incl. connectors Weight: 125g (4.4oz)																		
Ambient	5 - 40°C (41 - 104°F) 90% Humidity (non condensing)																		
Model #	OSW 1022- (EAN# 4250479327443)																		
Includes	Module, AC power supply																		

Application Examples

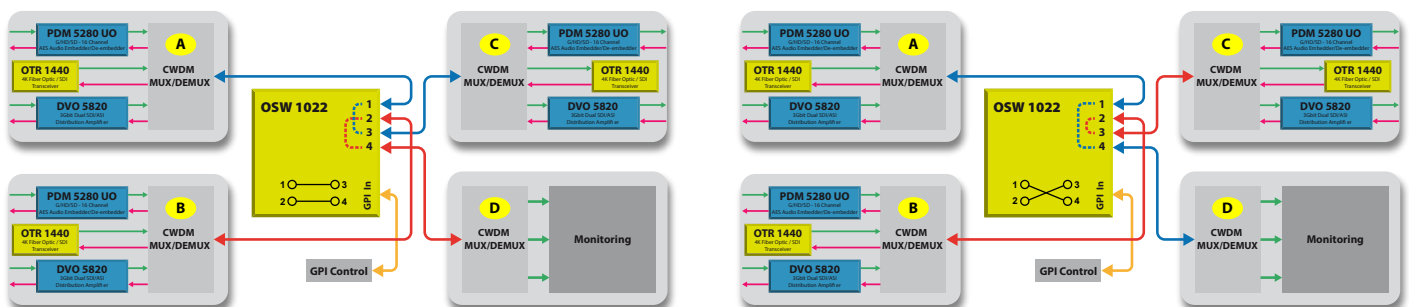

Type A: Straight Connection (GPI Triggered)

Type B: Cross Connection (GPI Triggered)

OCM 1891

9 Channel CWDM Mux/Demux [1270nm-1430nm]

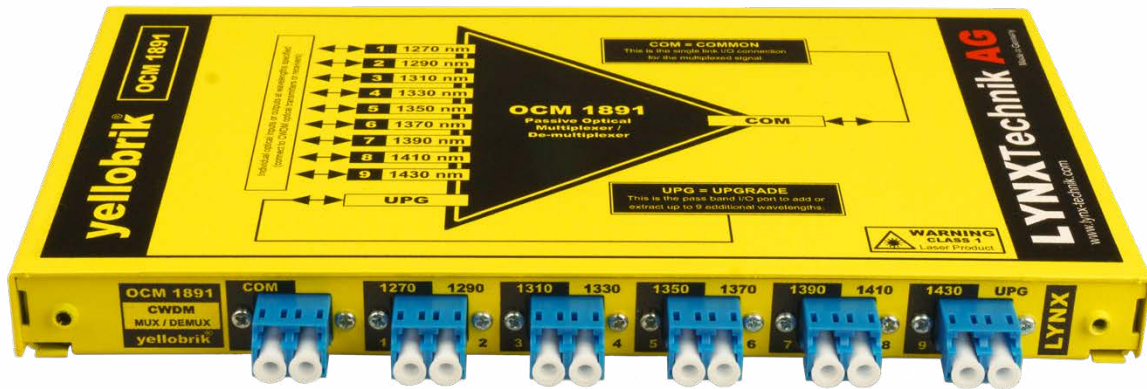

Visit the product page:



Features

- Send / receive up to 9 channels over a single fiber
- 1270nm to 1430nm (ITU-T G.694.2)
- Passive operation (no power required)
- Combine with OCM 1892 for 18 channels
- LC/PC single mode optical connections
- Optional 1/2 RU 19" rack frame

Description

The OCM 1891 is a compact CWDM passive 9 channel optical multiplexer / demultiplexer designed to send or receive up to 9 individual signals over a single fiber link. The module has an UPG (Upgrade) port to connect to the OCM 1892, which expands the capability of the modules to 18 CWDM channels

The modules can be used standalone or integrated into the optional RFR 1018 1/2 RU 19" rack frame, ideal for system installations.

Ideally suited for use with the CWDM yellobrik fiber modules (all 18 wavelengths available).

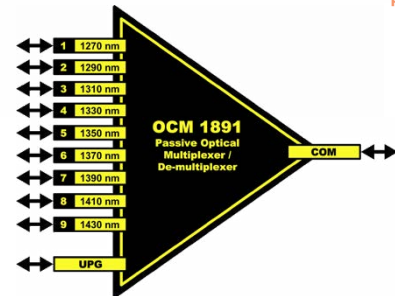

Technical Specifications

Optical I/O	9 x Fiber Optic I/O channels (1 through 9) Center frequencies taken from ITU-T G.694.2 1270,1290,1310,1330,1350,1370,1390,1410,1430 nm
	1 x COM (common) connection = multiplexed I/O
	1 x UPG (Upgrade) I/O connection (pass band connection to OCM 1892 module)
	LC/PC connectors SMF (single mode)
	Channel Insertion loss: 2.7dB UPG Insertion loss: 2.7dB
	Polarization dependant loss: max 0.2dB
	Return Loss: > 45dB
	Isolation (to adjacent channel): > 30dB
	Directivity > 55dB
	Temp. dependant loss: < 0.005dB/°C
	Temp. dependant change of wavelength: < 0.003nm/°C
	Max. input power: 500mw
	Single or full duplex operation
Power	None required (passive operation)
Physical	Size: L: 108mm x W: 198mm x H:19mm (4.25" x 7.79" x 0.75") Weight: 230g (8.1oz)
Model #	OCM 1891 - (EAN# 4250479318915)
Includes	Module

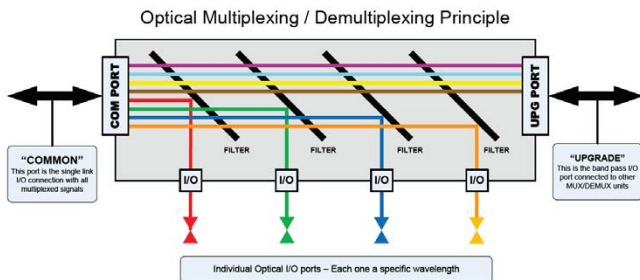

Example shown above has been arranged this way to show nomenclature typically used for optical multiplexer/ de-multiplexer port descriptions.

OCM 1892

9 Channel CWDM Mux/Demux [1450nm-1610nm]

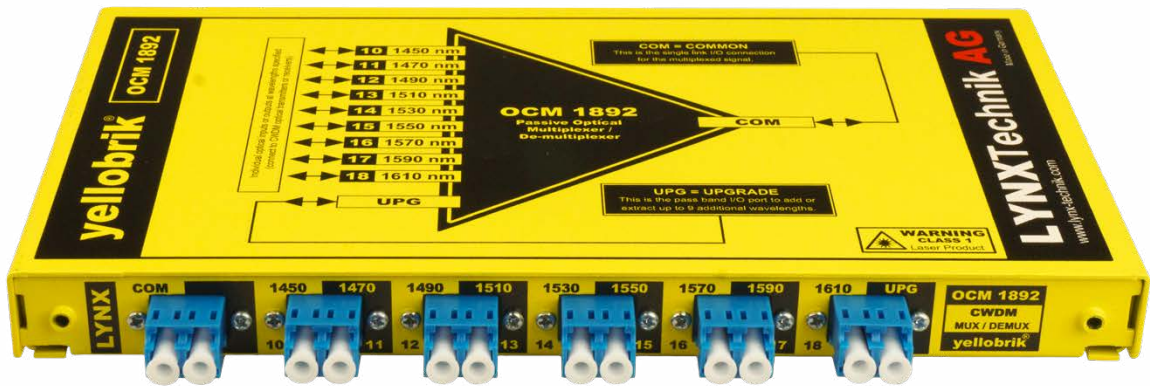

Features

- Send / receive up to 9 channels over a single fiber
- 1450nm to 1610nm (ITU-T G.694.2)
- Passive operation (no power required)
- Combine with OCM 1891 for 18 channels
- LC/PC single mode optical connections
- Optional 1/2 RU 19" rack frame

Description

The OCM 1892 is a compact CWDM passive 9 channel optical multiplexer / demultiplexer designed to send or receive up to 9 individual signals over a single fiber link. The module has an UPG (Upgrade) port to connect to the OCM 1891, which expands the capability of the modules to 18 CWDM channels

The modules can be used standalone or integrated into the optional RFR 1018 1/2 RU 19" rack frame, ideal for system installations.

Ideally suited for use with the CWDM yellobrik fiber modules (all 18 wavelengths available).

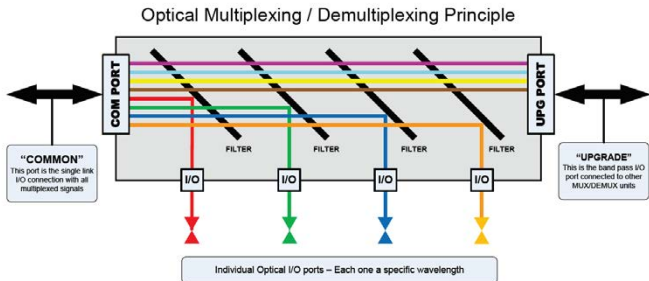

Example shown above has been arranged this way to show nomenclature typically used for optical multiplexer/ de-multiplexer port descriptions.

Visit the product page:

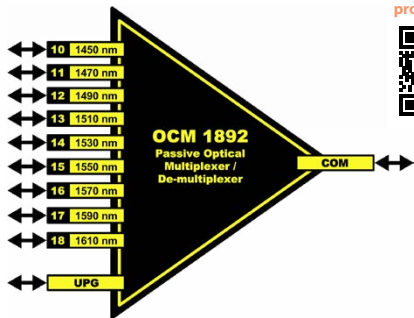

Technical Specifications

Optical I/O	9 x Fiber Optic I/O channels (10 through 18) Center frequencies taken from ITU-T G.694.2 1450,1470,1490,1510,1530,1550,1570,1590,1610 nm
	1 x COM (common) connection = multiplexed I/O
	1 x UPG (Upgrade) I/O connection (pass band connection to OCM 1892 module)
	LC/PC connectors SMF (single mode)
	Channel Insertion loss: 2.7dB UPG Insertion loss: 2.7dB
	Polarization dependant loss: max 0.2dB
	Return Loss: > 45dB
	Isolation (to adjacent channel): > 30dB
	Directivity > 55dB
	Temp. dependant loss: < 0.005dB/°C
	Temp. dependant change of wavelength: < 0.003nm/°C
	Max. input power: 500mw
	Single or full duplex operation
Power	None required (passive operation)
Physical	Size: L: 108mm x W: 198mm x H:19mm (4.25" x 7.79" x 0.75") Weight: 230g (8.1oz)
Model #	OCM 1892 - (EAN# 4250479318922)
Includes	Module

Video
Audio
Data
Optical
Racks
Optional

**OCM 1841, OCM 1842,
OCM 1843, OCM 1844**

4 Channel CWDM Mux/Demux

Video

Audio

Data

Optical

Racks

Optional

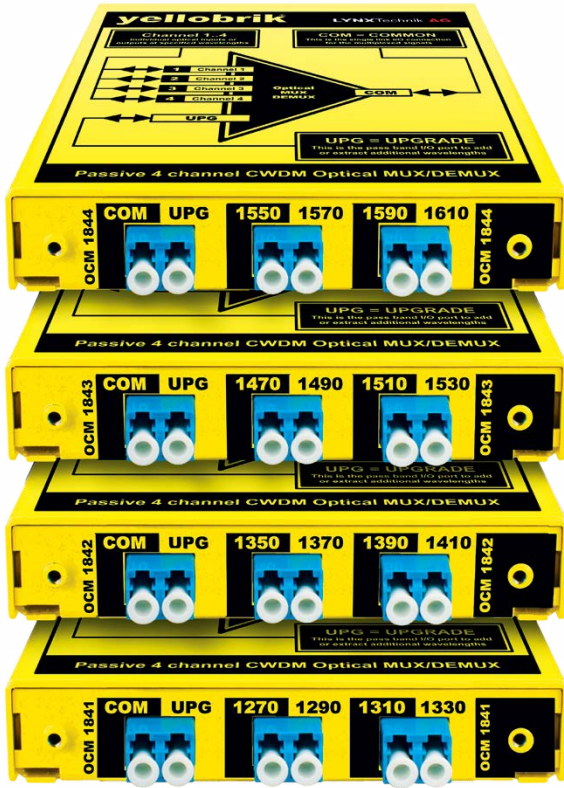

Visit the product pages:



OCM 1844



OCM 1843



OCM 1842



OCM 1841

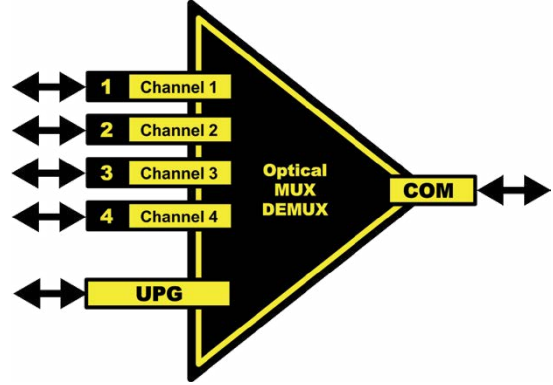

Model	Channel 1	Channel 2	Channel 3	Channel 4
OCM 1841	1270nm	1290nm	1310nm	1330nm
OCM 1842	1350nm	1370nm	1390nm	1410nm
OCM 1843	1470nm	1490nm	1510nm	1530nm
OCM 1844	1550nm	1570nm	1590nm	1610nm

Features

- Send / receive up to 4 channels over a single fiber link
- Passive operation (no power required)
- Combine all four modules for up to 16 channels
- LC/PC single mode optical connections
- Optional ½ RU 19" rack frame (RFR 1018)

Description

The OCM 1841, OCM 1842, OCM 1843, OCM 1844 are compact CWDM passive 4 channel optical multiplexers / demultiplexers designed to send and receive up to 4 individual signals over a single fiber link. Each module has an UPG (Upgrade) port to cascade into the other 4 channel modules, expanding the capability of the system to a maximum of 16 channels.

The modules can be used standalone or integrated into the optional RFR 1018 1/2 RU 19" rack frame, which can accommodate all four modules. Ideal for system installations.

Ideally suited for use with the CWDM yellobrik fiber modules (all 16 wavelengths are available).

Technical Specifications

Optical I/O	4 x Fiber Optic I/O channels Center frequencies taken from ITU-T G.694.2 OCM 1841 = 1270,1290,1310,1330nm OCM 1842 = 1350,1370,1390,1410nm OCM 1843 = 1470,1490,1510,1530nm OCM 1844 = 1550,1570,1590,1610nm 1 x COM (common) connection = multiplexed I/O 1 x UPG (Upgrade) I/O connection (pass band connection to other OCM 189x modules) LC/PC connectors SMF (single mode) Channel Insertion loss: 2.7dB , UPG Insertion loss: 1dB Polarization dependant loss: max 0.2dB Return Loss: > 45dB Isolation (to adjacent channel): > 30dB Directivity > 55dB Temp. dependant loss: < 0.005dB/°C Temp. dependant change of wavelength: < 0.003nm/°C Max. input power: 500mw Single or full duplex operation
Power	None required (passive operation)
Physical	Size: 120mm x 100mm x 19mm (4.72" x 3.93" x 0.75") Weight: 140g (4.9oz)
Model #	OCM 1841 - (EAN# 4250479319417) OCM 1842 - (EAN# 4250479319424) OCM 1843 - (EAN# 4250479319431) OCM 1844 - (EAN# 4250479319448)
Includes	Module

**OSP 1812,
OSP 1812M, OSP 1814**

Passive Optical Splitters



Visit the product pages:



OSP 1812



OSP 1812M



OSP 1814

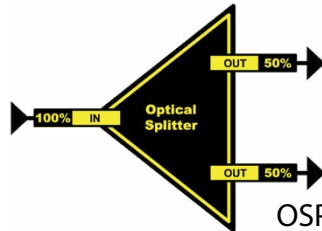

OSP 1812

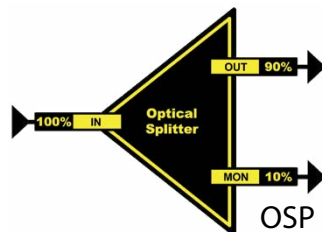

OSP 1812 M

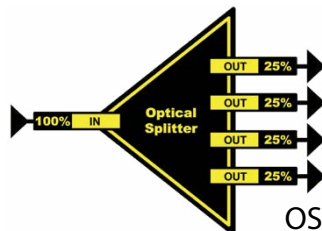

OSP 1814

Features

- Send / receive up to 4 channels over a single fiber link
- Passive operation (no power required)
- Combine all four modules for up to 16 channels
- LC/PC single mode optical connections
- Optional 1/2 RU 19" rack frame (RFR 1018)

Description

The OSP 1812, OSP 1812 M and OSP 1814 are compact optical splitters that are used to split or combine a fiber optic signal.

Three versions are available:

OSP 1812

One input (100%) and two outputs (each 50%)

OSP 1812 M

One input (100%) and two outputs, one at 90% power and a second at 10% power. Typically used as a monitoring output.

OSP 1814

One input (100%) and four outputs (each 25%)

These yellobriks are passive in operation, which means they require no power. They can be used as standalone modules or mounted into the yellobrik RFR 1018 19" rack frame.

Technical Specifications

OSP 1812 Optical I/O	1 x Fiber input 2 x Fiber outputs Split Ratio: 50% / 50%
OSP 1812 M Optical I/O	1 x Fiber input 2 x Fiber outputs Split Ratio: 90% / 10%
OSP 1814 Optical I/O	1 x Fiber input 4 x Fiber outputs Split Ratio: 25% / 25% / 25% / 25%
Optical Connections	LC/PC (singlemode) Operating wavelength 1260nm - 1650nm
Performance	Insertion loss (including connector) OSP 1812 and OSP 1812M = 4.0 dB OSP 1814 = 7.6dB Polarization dependant loss: max 0.3dB Return loss: > 55dB Directivity: > 55dB Max input power: 500mW
Power	None required (passive operation)
Physical	Size: L: 125mm x W: 100mm x H:19mm (4.92" x 3.93" x 0.75") Weight: 120g (4.3oz)
Ambient	-40°C to +70°C (-41 to 185°F) 90% Humidity (non condensing)
Model #	OSP 1812 - (EAN# 4250479359796) OSP 1812 M - (EAN# 4250479359802) OSP 1814 - (EAN# 4250479359819)
Includes	Module

Video
Audio
Data
Optical
Racks
Optional

Fiber Adapter Options

LYNXTechnik offers wide support of varying optical connections with yellobriks that support the usage of SFP modules. Whether you're using LC/PC, ST/PC, or SC/PC Connections, we've got you covered.

Sometimes though certain modules are just available as one type of optical connector. For this, we're offering broadcast-quality optical adapter kits. These

adapter kits allow the use of ST, SC, and FC fiber connections on the module. These are SMF, have a length of 0.5m (19.6"), and introduce less than 0.25dB attenuation. Each kit is measured and has the precise attenuation printed on the packaging it comes with.

All kits are available as Simplex (SIM) and Duplex (DUP) variants.

LC/SC DUP

Duplex LC/PC to SC/PC Adapter

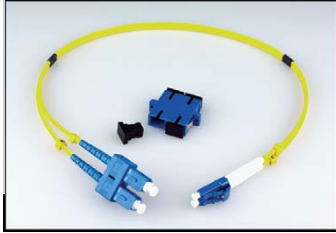

Technical Specifications

Attenuation	<0.25dB
Physical	Length: 0.5m (19")
Connectors	LC/PC, SC/PC (Duplex)
Model #	LC/SC DUP

LC/SC SIM

Simplex LC/PC to SC/PC Adapter

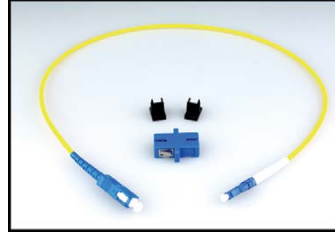

Technical Specifications

Attenuation	<0.25dB
Physical	Length: 0.5m (19")
Connectors	LC/PC, SC/PC (Simplex)
Model #	LC/SC SIM

LC/ST DUP

Duplex LC/PC to ST/PC Adapter

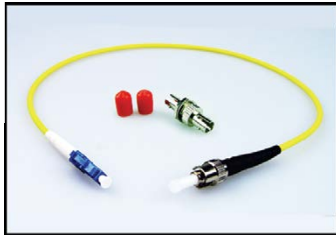

Technical Specifications

Attenuation	<0.25dB
Physical	Length: 0.5m (19")
Connectors	LC/PC, ST/PC (Duplex)
Model #	LC/ST DUP

LC/ST SIM

Simplex LC/PC to ST/PC Adapter

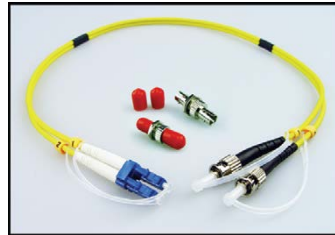

Technical Specifications

Attenuation	<0.25dB
Physical	Length: 0.5m (19")
Connectors	LC/PC, ST/PC (Simplex)
Model #	LC/ST SIM

LC/FC DUP

Duplex LC/PC to FC/PC Adapter



Technical Specifications

Attenuation	<0.25dB
Physical	Length: 0.5m (19")
Connectors	LC/PC, FC/PC (Duplex)
Model #	LC/FC DUP

LC/FC SIM

Simplex LC/PC to FC/PC Adapter

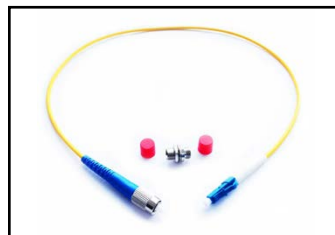

Technical Specifications

Attenuation	<0.25dB
Physical	Length: 0.5m (19")
Connectors	LC/PC, FC/PC (Simplex)
Model #	LC/FC SIM

LC/LC DUP

Duplex LC/PC Patch Cable



Technical Specifications

Attenuation	<0.25dB
Physical	Length: 0.5m (19")
Connectors	LC/PC (Duplex)
Model #	LC/LC DUP

LC/LC SIM

Simplex LC/PC Patch Cable

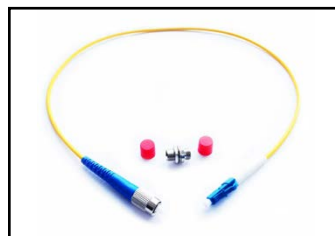

Technical Specifications

Attenuation	<0.25dB
Physical	Length: 0.5m (19")
Connectors	LC/PC (Simplex)
Model #	LC/FC SIM

*Distance is an approximation. Actual distances achieved can be longer or shorter depending on the type of cable. Determine link losses and perform optical budget calculations to ensure correct operation.

RPS 1001

12V/15W AC to DC Power Supply for Single yellobrick



Visit the product page:



Features

- Wide Operating Voltage 90-264V AC, 47 to 63 Hz
- Interchangeable Plug
- Single Output
- Class II
- Energy Star 2.0, Efficiency level V

Description

The RPS 1001 AC/DC switching mode external wall plug power supply unit provides 15 watts of continuous output power. This power supply unit is meant to be used with a single yellobrick module.

Electrical Characteristics

Safety Approvals	Input Voltage Range	100~240 V AC
Operate Voltage Range	90~264 V AC	
Input Frequency	47~63 Hz	
Output Power Range	15 W (max.)	
Output Voltage Range	11 ~ 13 V DC	
Output Current Range	1.15 ~ 1.36 A	
Input Current (Low Line)	Io=Full load, Vin=100V AC	0.4A (max.)
Input Current (High Line)	Io=Full load, Vin=240V AC	0.16A (max.)
Low Line Inrush Current	Io=Full load, 25°C, Cool start, in=100V AC	35~45A
High Line Inrush Current	Io=Full load, 25°C, Cool start, Vin=240V AC	70~90A
Efficiency	Io=Full Load, Vin=230V AC	84.2%
Line Regulation	Io=Full Load	0.5~1 %
Load Regulation	Vin=230V AC	4~5 %
Over Voltage Protection		Nil
Over Current Protection		Nil, But, Output protected to short circuit conditions
Time of Transient Response	Io=Full Load to Half Load, Vin=100VAC	4 ms (max.)
Hold-Up Time	Io=Full Load, Vin=110V AC	8 ms (min.)
Start Up Time	Io=Full Load, Vin=100~240V AC	3 s (max.)
Ripple & Noise	Full Load, Vin=90V AC	200mV _{p-p}
Leakage Current	Vin=240VAC/60Hz	0.25 mA (max.)
Temperature Coefficient	All output	±0.04 %/ °C
No-Load Power Consumption	No load, Vin=230V AC	0.1 W
Dielectric Withstanding Voltage for Primary to secondary		4242V DC (min.)

Environmental

Operating Temperature	See derating curve
Storage Temperature	-40~85°C
Operating Humidity	0~95%
Storage Humidity	0~95%
Operating Temperature at 25 C Calculated per MIL-HDBK-217F	0.1M Hrs (min.)
Derate linearly from 100% load at 40°C to 50% load at 70°C	

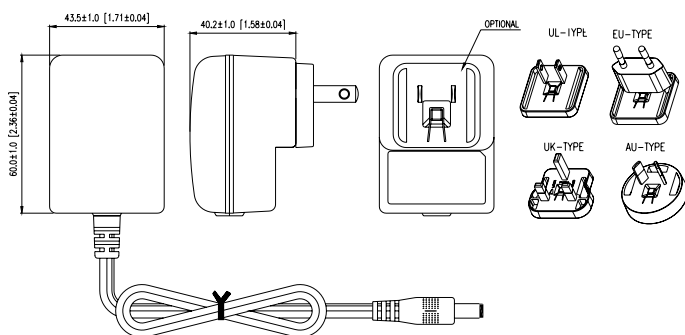

Note: Dimensions are shown in mm

Ordering Information

EAN	Model	Description
4250479310018	RPS 1001	External wall plug power supply for single yellobrick

RPS A100

12V/100W AC to DC Desktop Power Supply



Visit the product page:



Description

The RPS A100 AC to DC Desktop power supply unit provides 100 watts of continuous output power. The power supply is equipped with IEC320-C14 AC inlet. This power supply can be used with yellowbrik rack frames.

Features

- Wide Operating Voltage 100 to 240 VAC, 50 to 60 Hz
- 100W Output Power
- Active Power Factor Correction (PFC) function
- Energy efficiency level VI or CoC Tier II
- LED indicator for Power on

Technical Specifications

Output	DC Voltage	12V
	Rated Current	8.33A
	Current Range	0~8.33A
	Rated Power (max.)	100 W
	Ripple & Noise (max)	240mVp-p
	Line Regulation	±1.0%
	Load Regulation	±5.0%
Input	Voltage Range	100~240VAC
	Frequency Range	50~60Hz
	Input Current	≤2.0A
	Inrush Current (max.)	60A/100V AC - 120A/230V AC
	Hold Up Time	≥8.3ms
	Turn On Time	≤3s
Protection	Short Circuit Protection	Auto Recovery
	Over Voltage Protection	Latch-Off
	Over Current Protection	Auto Recovery
	Over Temperature Protection	Latch-Off
Physical	Case Size (L/W/H)	137mm x 59mm x 34mm
	Weight	450g
Ambient	Operating Temperature	0 to 40°C
	Storage Temperature	-20 to 85°C
	Operating Humidity	10% to 90%
	Storage Humidity	5% to 95%
Safety	Safety Standards	UL/cUL 62368-1, TUV EN 62368-1, CB IEC 62368-1, FCC, CE, BSMI, PSE, RCM, IRAM

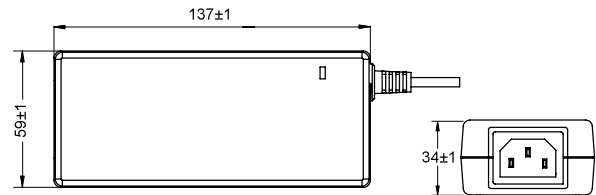

Note:
1. Measurements are in mm
2. Net weight: approx. 450g

Connector	Pin Assignment	
	1	GND
	2	NC
	3	NC
	4	+12V

Ordering Information

EAN	Model	Description
4250479327955	RPS A100	AC to DC Desktop Power Supply Module 12V/8A

Ordering Code

RPS A100 N
RPS A100 EU
RPS A100 UK
RPS A100 US

Description

Power Supply without Power Cord
Power Supply with EU Power Cord
Power Supply with UK Power Cord
Power Supply with US Power Cord



Power Adapter Options

P-TAP 1000



Use with a standard battery P-TAP power source.

Technical Specifications

Physical	Length(incl. connectors): 2m (6.5 feet)
Connectors	P-Tap Male / Barrel Con.(ø 5.5mm/L:7mm)
Model #	P-Tap 1000

XLR 1000



Use with standard 4 pin XLR camera battery power source.

Technical Specifications

Physical	Length(incl. connectors): 1.9m (6.2 feet)
Connectors	4 Pin XLR / Barrel Con.(ø 5.5mm/L:7mm)
Model #	XLR 1000

Knowledge Base

We have lots of articles, tips, and tutorial videos which should answer most of your questions. Just visit the LYNXTechnik knowledge base.



support.lynx-technik.com

Get in Touch

Can't find the information you need? Feel like something is missing on our websites? Looking for oem prices? Get in touch and contact us via or contact form or open a support ticket here:

Need assistance with a product?



ticket.lynx-technik.com

Need help finding the right product?



salescontact.lynx-technik.com

European Headquarters
LYNX Technik AG

Phone: + 49 (0) 6150 1817 0
Fax: + 49 (0) 6150 1817 100



info@lynx-technik.com

USA Headquarters
LYNX Technik USA

Phone: (661) 251 8600
Fax: (661) 251 8088



info@lynx-usa.com

APAC Headquarters
LYNX Technik Pte Ltd

Phone: + 65 6702 5277
Fax: + 65 6385 5221



infoasia@lynx-technik.com



*Distance is an approximation. Actual distances achieved can be longer or shorter depending on the type of cable. Determine link losses and perform optical budget calculations to ensure correct operation.

Notes

The page contains a large grid of dotted lines for taking notes. A solid yellow horizontal line is positioned at the top of the grid, just below the 'Notes' header.

LYNX Technik AG [EMEA]

Phone: +49 (0) 6150 1817 0
Fax: +49 (0) 6150 1817 100
Email: info@lynx-technik.com

LYNX Technik Pte Ltd [APAC]

Phone: +65 6702 5277
Fax: +65 6385 5221
Email: infoasia@lynx-technik.com

LYNX Technik USA [AMER]

Phone: (661) 251 8600
Fax: (661) 251 8088
Email: info@lynx-usa.com

WARRANTY INFORMATION

LYNX Technik AG warrants that the product will be free from defects in materials and workmanship for a period of three (3) years from the date of shipment or online activation if applicable. If this product proves defective during the warranty period, **LYNX Technik AG**, at its option, will either repair the defective product without charge for parts and labor, or will provide a replacement in exchange for the defective product.

In order to obtain service under this warranty, customer must notify **LYNX Technik AG** of the defect before expiration of the warranty period and make suitable arrangements for the performance of service. Customer shall be responsible for packaging and shipping the defective product to the service center designated by **LYNX Technik AG**, with shipping charges prepaid. **LYNX Technik AG** shall pay for the return of the product to the customer if the shipment is within the country which the **LYNX Technik AG** service center is located. Customer shall be responsible for payment of all shipping charges, duties, taxes and any other charges for products returned to any other locations.

This warranty shall not apply to any defect, failure, or damage caused by improper use or improper or inadequate maintenance and care. **LYNX Technik AG** shall not be obligated to furnish service under this warranty

a) to repair damage resulting from attempts by personnel other than **LYNX Technik AG** representatives to install, repair or service the product;

b) to repair damage resulting from improper use or connection to incompatible equipment;

c) to repair any damage or malfunction caused by the use of non **LYNX Technik AG** supplies; or d) to service a product which has been modified or integrated with other products when the effect of such modification or integration increases the time or difficulty servicing the product.

THIS WARRANTY IS GIVEN BY LYNX TECHNIK AG WITH RESPECT TO THIS PRODUCT IN LIEU OF ANY OTHER WARRANTIES, EXPRESS OR IMPLIED. LYNX TECHNIK AG AND ITS VENDORS DISCLAIM ANY IMPLIED WARRANTIES OF MERCHANTABILITY OR FITNESS FOR A PARTICULAR PURPOSE. LYNX TECHNIK'S RESPONSIBILITY TO REPAIR AND REPLACE DEFECTIVE PRODUCTS IS THE SOLE AND EXCLUSIVE REMEDY PROVIDED TO THE CUSTOMER FOR BREACH OF THIS WARRANTY. LYNX TECHNIK AG AND ITS VENDORS WILL NOT BE LIABLE FOR ANY INDIRECT, SPECIAL, INCIDENTAL, OR CONSEQUENTIAL DAMAGES IRRESPECTIVE OF WHETHER LYNX TECHNIK AG OR THE VENDOR HAS ADVANCE NOTICE OF THE POSSIBILITY OF SUCH DAMAGES.



yellobrik.lynx-technik.com

European Headquarters

LYNX Technik AG

Brunnenweg 3
D-64331 Weiterstadt
Germany

Phone: + 49 (0) 6150 1817 0
Fax: + 49 (0) 6150 1817 100
Email: info@lynx-technik.com

APAC Headquarters

LYNX Technik Pte Ltd

114 Lavender Street
#05-92 CTHub2
Singapore 338729

Phone: + 65 6702 5277
Fax: + 65 6385 5221
Email: infoasia@lynx-technik.com

USA Headquarters

LYNX Technik USA

26366 Ruether Ave
Santa Clarita, CA 91350
USA

Phone: (661) 251 8600
Fax: (661) 251 8088
Email: info@lynx-usa.com

www.lynx-technik.com



lynxtechnik



lynxtechnik



lynx-technik-ag



lynxtechnikag