

greenMachine®



Quick Reference Guide



Introduction

This Quick Reference Guide provides information related to greenMachine HDR Evie+ initial setup and configuration. greenMachine HDR Evie+ (Enhanced Video Image Engine plus), 1 RU half 19" rackmount, is a real-time segmented frame-by-frame broadcast-quality High Dynamic Range (HDR) to Standard Dynamic Range (SDR) converter, with frame sync supporting formats up to 4K UHD (3840x2160). It is the world's first system that uses the advanced algorithm for sectional dynamic tone mapping which automatically analyses different sections of an image in HDR stream and applies optimal corrections on a frame by frame basis in real-time. This unique capability is unlike any other solution today. It is the perfect real-time production tool for sports or any live broadcast event needing high-quality real-time HDR to SDR conversions. HDR EVIE+ fits best in the single native HDR workflow reducing cost on equipment and manual operations.

This quick reference guide is designed to help you setup greenMachine HDR Evie+ and provides the step-by-step instructions to configure your HDR Evie+ to achieve the best possible down-conversion from HDR to SDR for your operations. For additional information, please refer to the "HDR Evie+ Reference Manual."

Unpacking greenMachine HDR Evie+

The greenMachine HDR Evie+ comes with the following items:

- 1x Segmented Dynamic HDR to SDR Converter Constellation: GMC-HDR-EVIE+-titan
- 1x Static HDR Conversion Constellation: GMC-HDR-STATIC-titan
- 1x greenMachine Titan: GM6840
- 1x external power supply (RPS 6120)
- 1x power cord (EU, UK, or US)
- 1x SubD 25 audio adapter PCB
- 1x quick reference guide
- 1x warranty card

Quick-Setup Guide

The following sections will guide you in setting up a new greenMachine segmented dynamic HDR to SDR converter (HDR Evie+). The quick setup is divided into two sections:

Section 1: This section will demonstrate the initial preparation of hardware and software setup

Section 2: This section will demonstrate the HDR Evie+ configuration and settings for Segmented Dynamic HDR to SDR conversion.

Section 1: greenGUI (Software) and greenMachine (Hardware) setup

This section will demonstrate how to setup greenGUI software on a PC or MAC and will also demonstrate how to set up the greenMachine hardware.

1. greenGUI Installation

If you do not already have the greenGUI software installed on your PC or MAC, then download and install the greenGUI software from Lynx Technik AG website from the link below:

<https://www.lynx-technik.com/downloads/greengui/>

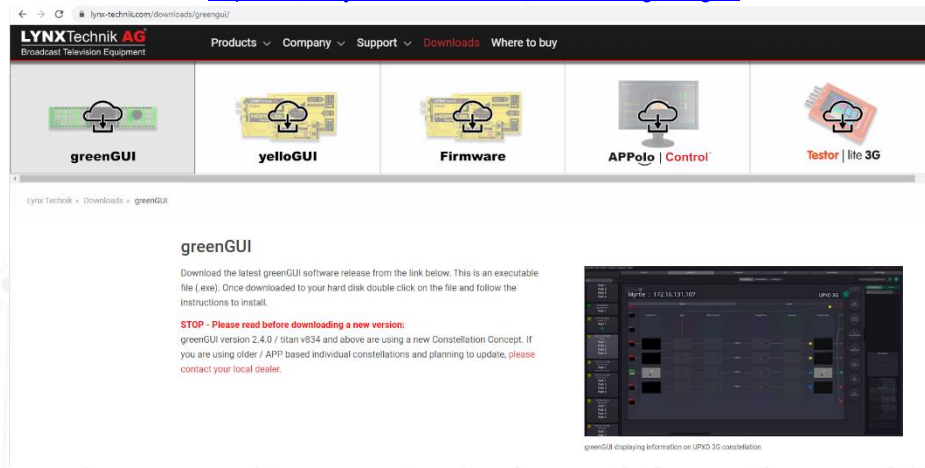

Install and start the greenGUI software on your PC or MAC.

2. greenMachine Network Connection

Connect the greenMachine via LAN Port to the same network with your PC or MAC on which the greenGUI is installed.

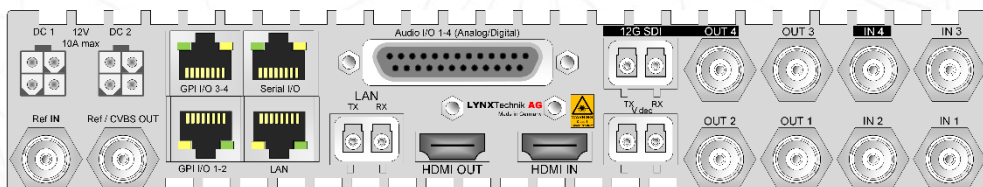

Power up the greenMachine and wait for it to finish booting.

3. IP Network Settings

The greenMachine is a networked device and may require network settings for it to be connected to the network. By default, the IP setting of the greenMachine is set to DHCP. If the network to which greenMachine is connected uses a

DHCP server, then the greenMachine will automatically capture the IP address and other settings. The greenMachine will appear on the greenGUI.



greenMachine Evie+

If the network to which greenMachine is connected to does not have a DHCP server, then configure the IP settings manually from the front panel of the greenMachine as shown in the steps as below:

	<p>1 Press the “System” button to access the Menu</p>
	<p>2 Using the rotary knob, highlight “IP settings” and press to enter</p>
	<p>3 Highlight IP mode and rotate the knob to select “static” in the middle of the screen and press to enter (default is DHCP mode).</p>
	<p>4 Using the menu system and rotary control, make the required manual numeric entries for the IP address, Gateway, and Netmask. Please ask your network/IP support for the settings if needed.</p>
<p>Note: The values given in the pictures above are for demonstration purposes only. Once IP settings are completed, exit the IP setting menu. The greenMachine will now be visible on the greenGUI running on your PC or MAC.</p>	

4. Video/Audio Connection

Connect your HDR Video Signal to the input port/s provided at the back panel of the greenMachine. A user can either select to use four 3G SDI inputs or one 12G SDI/fiber input depending on the requirement. greenMachine provides

four 3G SDI outputs or one 12G SDI/fiber output*. (*HDR Evie+ constellation supports only one 4K/UHD processing channel)

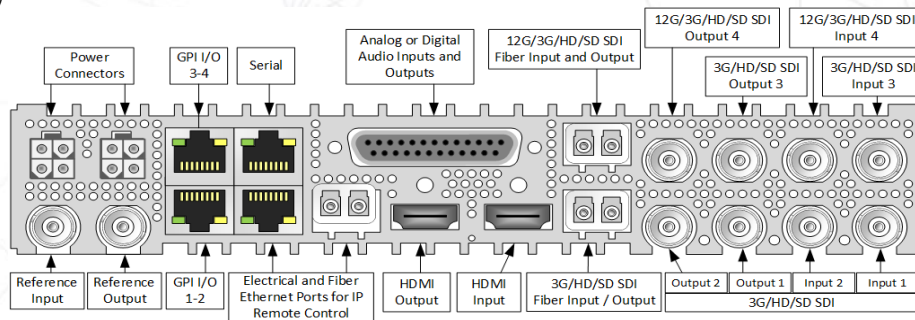

For example, if the input video signal from the Camera or any other video source is connected to SDI input 1, on the greenMachine, on greenGUI Control> Main would display a similar page as shown below:

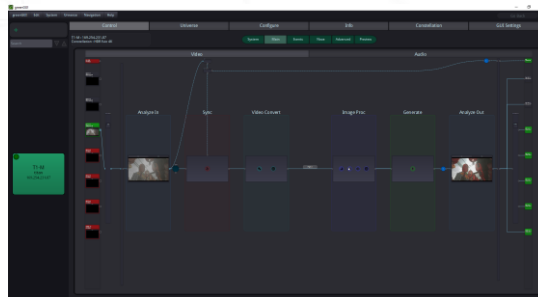

greenMachine Evie+

Connect the input ports on the greenMachine as required, considering the limitation of each input and output port. Check greenMachine ports detail in the back-panel picture, as shown above.

5. Reference input connection

Connect the video reference input port on the greenMachine to a reference source. In case no external input reference source is available, the user can take the input video signal as the reference source as shown in the picture below:

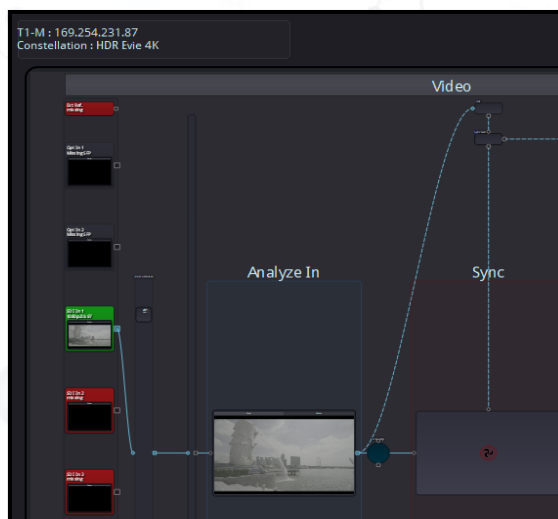

greenMachine Evie in 4K mode Config.

6. Deploying HDR Evie+ constellation (Optional*)

Note: To enable zoom in or zoom out, users can use the mouse scroller or can double click.

* A new greenMachine HDR Evie+ comes with the pre-deployed HDR Evie+ constellation. In case the constellation needs to be re-deployed, follow the below steps:

	<p>1 On the greenGUI software, click on the Universe page</p>
	<p>2 Zoom in to the greenMachine. Verify the name or the IP address of the greenMachine for which the constellation type needs to be changed. (Reconfirm if the correct greenMachine is selected). In case there are many greenMachines connected on the network, double click on the greenMachine box on the left of the UI on the Rolodex, as shown in the picture below in blue color, and the system will zoom on to the correct machine.</p>
	<p>3 On the right pane under the Constellation tab, use the mouse to scroll down to HDR Evie+. Press the left mouse button on the HDR Evie+ box and drag and drop it on the left inside the window, as shown in the image. The user will see the gear icon if done correctly, and the window shown in next will appear.</p>
	<p>4 Click on the Deploy button to deploy the HDR Evie+ constellation</p>

Section 2: HDR Evie+ Configuration

This section will guide you in setting up a new greenMachine HDR Evie+ constellation.

Note: The settings shown in this Quick Reference Guide is for demonstration purpose only. The user should set the values and parameters depending on the actual operational requirements and preferences. Use mouse scroller to Zoom in/out on the page **Control > Main** on greenGUI.

1. HDR Evie+ Video Parameters

Perform the following steps to set up your greenMachine HDREvie+ video Settings.

Note: To enable zoom in or zoom out, users can use the mouse scroller or can double click.

	<p>1 Go to Control > Main and click on the Video tab as shown in the picture</p>
	<p>2 The window shown in the picture will appear.</p>
	<p>3 Zoom in to Video Convert processing block as shown in the picture</p> <p>4 The window shown in the picture will appear. The page displays the input characteristics and gives an option of selecting the parameters for the output. The option provided for the MetaData are <i>Closed Captions, Time Code, Teletext, and Misc.</i> The Global Settings provides three options to the user to select what output to be shown in case there is no input signal. The options are <i>Test Pattern, Black, or Freeze.</i></p>
	<p>5 Zoom out and zoom in to Image Proc as shown in the picture</p> <p>6 The window shown in the picture will appear. The options provided to the user are: 1. Video Adjust 2. Color Correction 3. HDR Evie+</p>



7 Click on the **Video Adjust** tab
 In the Video Adjust settings, the user is provided with the options for *clipping YCrCb headroom*, *Horiz Flip*, *Blanking (H/V Blanking)*, and video settings like *Gain*, *Sat*, *Black*, *Hue*, and *Aperture*. Set the parameters as required.

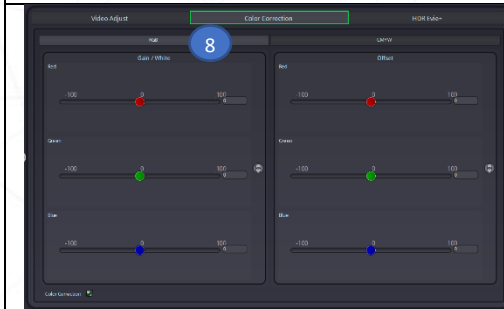

8 Click on the **Color Correction** tab
 In the Color Correction settings, the user is provided with the options of changing Gain and Offset in *RGB* and *CMYK*. Click on the tab as shown below and adjust the corresponding parameter in the settings as required

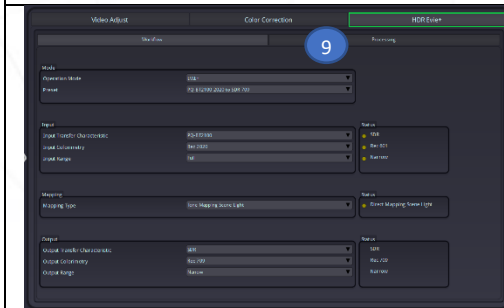
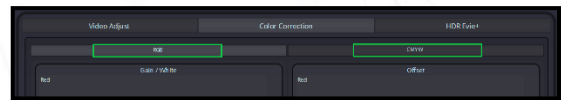

9 Click on HDR Evie+ tab
 The HDR Evie+ Panel presents *Workflow* and *Processing* options

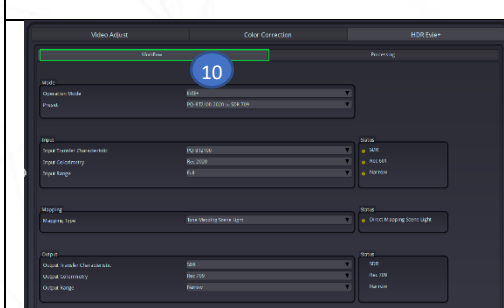

10 Select Workflow and adjust the parameters as required.
 (Check description of each parameter below)

10 Check the description of each parameter in the HDR Evie+ > Workflow page
 For detailed information on processing parameters, refer to the HDR Evie+ reference manual "Operations Mode."

Setting		Description
Mode	Operation Mode	<p>There are two options provided in Operation Mode which are <i>bypass HDR/SDR</i> and <i>EVIE+</i></p> <p>Bypass HDR/SDR: Selecting this option will bypass the HDR conversion functions such as transfer characteristics, colorimetry, and ranges. It means the incoming signal is transparently passed through the system.</p> <p>Note: In this mode, only "colorimetry" and "range" conversion of SDR signals can be performed.</p> <p>EVIE+: Selecting this option activates the actual operation of HDR EVIE+ constellation. It allows the user to perform HDR-to-SDR down-conversion.</p> <p><i>For more information on the Operation mode, refer to HDR Evie+ Reference manual "Operations Mode."</i></p>

	Presets	<p>There are several useful presets provided for quick operations. The following presets are available to the user for selection:</p> <div style="background-color: #333; color: #fff; padding: 5px; font-family: monospace; font-size: 0.8em;"> <p>Custom PQ-ST2084 2020 to SDR 709 PQ-BT2100 2020 to SDR 709 SLog3 2020 to SDR 709 HLG 2020 to SDR 709 Auto to Auto Auto to SDR 709</p> </div>
Input	Input Transfer Characteristics	<p>The following input transfer characteristics are provided: SDR, HLG, PQ-ST2084, PQ-BT2100, Slog3, Panasonic V-log, Arri LogC, RED Log3G10, Canon C-Log2, BMD Film</p> <p><i>For more information on Transfer characteristics, refer to HDR Evie+ reference manual "Transfer characteristics."</i></p>
	Input Colorimetry	<p>The following Colorimetry is provided: BT.2020, BT.709, Sony S-Gamut, ACES, DCI-P3, Panasonic V-Gamut, BMD Film, Canon Cinema Gamut, Arri Alexa, Red Wide Gamut</p> <p><i>For more information on Colorimetry, refer to HDR Evie+ reference manual "Colorimetry / Gamut."</i></p>
	Input Range	<p>The following input ranges are provided: Full, Narrow, and Auto</p> <p>Full: Full Range is the complete range of bits used for representing blacks and whites. For example, in a 10-bit signal, 0 bit represents the black, and 1023 bit represents the White.</p> <p>Narrow: Narrow Range is the limited range of bits used for representing black and whites. For example, in a 10-bit signal, 64 bit represents the Black, and 940 bit represents the White.</p> <p>Auto: In this mode, the system reads the VPID information on the signal to determine the "Narrow" or "Full" range.</p> <p><i>For more information on range, refer to HDR Evie+ Reference manual "Signal Range."</i></p>
Mapping	Mapping Type	<p>The tone mapping operation can be performed with two possible approaches depending on the user cases:</p> <ol style="list-style-type: none"> 1. Tone Mapping Scene light 2. Tone Mapping display light <p>Select Tone Mapping Scene light when the goal is to match the colors and relative tones of HDR and SDR cameras.</p> <p>Select Tone Mapping Display light when the goal is to preserve the colors and relative tones seen on a reference display.</p> <p><i>For more information on Mapping, refer to HDR Evie+ Reference manual "Mapping."</i></p>
Output	Output Transfer Characteristics	<p>The output transfer characteristics provided is SDR</p> <p><i>For more information on Transfer characteristics, refer to HDR Evie+ reference manual "Transfer characteristics."</i></p>
	Output Colorimetry	<p>The following output colorimetry is provided: Rec 709, Rec 2020, and Auto</p> <p>Note: In Auto mode, the output follows the input, and no conversion takes place</p> <p><i>For more information on Colorimetry, refer to the HDR Evie+ reference manual "Colorimetry / Gamut."</i></p>
	Output Range	<p>The following output range are provided: Full, Narrow, and Auto</p> <p>Full: Full Range is the complete range of bits used for representing blacks and whites. For example, in a 10-bit signal, 0 bit represents the black, and 1023 bit represents the White.</p>

		<p>Narrow: Narrow Range is the limited range of bits used for representing black and whites. For example, in a 10-bit signal, 64 bit represents the black, and 940 bit represents the white.</p> <p>Auto: In this mode, the output follows the input, and no conversion takes place. For example, if the input range is “Narrow,” then the output range will be “Narrow.”</p> <p><i>For more information on range, refer to HDR Evie+ Reference manual “Signal Range.”</i></p>
--	--	--





11 Select **Processing** in the HDR Evie+ tab and adjust the parameters as required
(Check description of each parameter below)

11 **Check the description of each parameter in the HDR Evie+ > processing page**
 For detailed information on processing parameters, refer to HDR Evie+ reference manual “Processing Parameters.”

Setting	Description
<i>Brightness</i>	<p>This parameter is used for adjusting the target brightness of the overall image. The target brightness is determined by the value of the mean gray. The default value is set to 1.0, which corresponds to 18% gray.</p> <p><i>Note: Higher value can lead to flattening of the image impression.</i></p> <p>2.0: gray = 36% 1.0: gray = 18% 0.5: gray = 9% Default Value: 1.00</p>
<i>Contrast</i>	<p>This determines the slope of the s-curve applied to the image. The default value is set to 1.10, and it slightly increases the contrast.</p> <p>2.0: extremely high contrast 1.0: contrast unchanged 0.0: extremely low contrast Default Value: 1.10</p>
<i>Saturation</i>	<p>Due to contrast compression by the Tone Mapping operation and possible adjustment of the “Target Brightness” and “Contrast,” an adjustment in the brightness component is performed, which influences the color impression such as saturation. If the saturation impression does not match the expectation, then the “saturation” parameter offers the possibility in adjustment. The default value is set to 0.9, which slightly reduces the saturation.</p> <p>2.0: Extremely increased saturation 1.0: Saturation unchanged 0.0: Extremely reduced saturation Default Value: 0.9</p>
<i>Adaptation speed</i>	<p>To get a consistent viewing impression, the values during the calculation of Tone Mapping are temporarily smoothed out. The duration of this interpolation can be selected by this parameter. The default value is 0.05 and is the recommended value.</p>

	<p>1.00: No smoothing at all (Caution!) 0.05: Normal adaption speed (recommended) 0.00: Extremely slow adaptation speed Default Value: 0.050</p> <p><i>Caution: This adjustment should only be made by experienced users since a higher adaptation speed can lead to a “pumping” effect.</i></p>
<i>Scene Change %</i>	<p>A scene change detection processing automatically detects the change of the scene. The detection of scene change allows the Tone mapping algorithm to automatically adjust its values and application relevant to the new scene. The adjustment of brightness can, therefore, be fast and more relevant to the new scene.</p> <p>This parameter determines the percentage at which a change in the image is detected as a scene change. If the change in brightness between two frames exceeds this percentage, that frame is classified as a scene change, and the image brightness is quickly adjusted. The lower the value of this parameter, the more likely a change between two frames is classified as a scene change. The default value is 55%.</p> <p>100%: No scene change detectable 55%: Normal scene change detection (Recommended-but depends on the material) 0%: Extremely fast (reckless*) scene change detection Default Value: 55%</p> <p><i>*Caution: If the “scene change %” is set too low, scene changes might be detected wrongly and may generate unwanted effects such as light/dark flickering. If the threshold is set too high, then the actual scene changes may not be detected at all, and brightness adaptation may happen too slowly.</i></p> <p><i>Note: If EVIE+ is not operated behind a program output but directly behind a camera, the “Scene Change” (%) can principally be deactivated by setting it to 100%. However, if large (and rapid) jumps in brightness are to be expected, it may be beneficial to use the “Scene Change” to counteract these (unless this behavior is not desired).</i></p>
<i>Clipping Intensity</i>	<p>Clipping intensity influences the automatic result of image analysis by controlling the strength of the clipping. Higher values will lead to stronger clipping which may cause burn out earlier and stronger. The default value is set 1.0</p> <p>2.0: Extremely strong clipping 1.0: Normal clipping 0.0: Almost no clipping Default Value: 1.0</p>
<i>Dynamic Ratio</i>	<p>It is possible to combine sectional dynamic tone mapping with a static tone mapping. The parameter “Dynamic Ratio” allows both techniques to be combined or mixed proportionally. A default value of 0.6 means the system offers 60% of the dynamic processing and 40% of the static processing.</p> <p>1.0: Dynamic tone mapping only 0.6: 60% dynamic tone mapping, 40% static tone mapping 0.5: 50% dynamic tone mapping, 50% static tone mapping 0.0: Static tone mapping only Default Value: 0.60</p>
<i>Homogenization</i>	<p>It is possible to combine sectional dynamic tone mapping with a global dynamic tone mapping, which corresponds to the operation of HDR Evie. The parameter “Homogenization” allows both techniques to be combined or mixed proportionally. A default value of 0.45 means the system offers 45% of the sectional dynamic processing and 55% of global dynamic processing.</p> <p>1.00: Sectional dynamic tone mapping only 0.50: 50% sectional dynamic tone mapping, 50% global dynamic tone mapping</p>

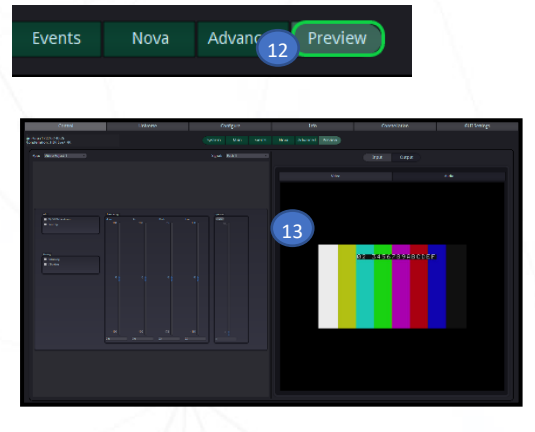
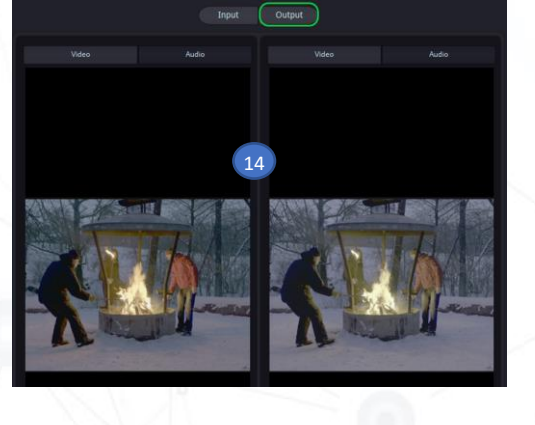
	<p>0.45: Default (45% sectional dynamic tone mapping, 55% global dynamic tone mapping) 0.0: Global dynamic tone mapping only</p> <p>CAUTION: If the “Homogenization” parameter is set too high and if only sectional dynamic processing is active, unwanted effects or artifacts such as unwanted brightening and darkening or halo artifacts may occur.</p>
<i>Black Lift</i>	<p>The “Black Lift” parameter allows the adjustment of dark areas of the image separately. If a high value for homogenization is selected, the shadows may be increased to an undesirable degree. The black lift parameter can be used to counteract this effect. A higher value of this parameter leads to higher brightness of the shadows, and lower value leads to lesser brightness of the shadows. The default value is set to 0.5.</p> <p>1.0: No limitation (Shadows are brightened to the maximum) 0.5: Slight limitation (shadows are slightly brightened) 0.0: Extreme limitation (shadows are not brightened)</p> <p>Note: Black lift parameter has no effect on the image impression if the Homogenization parameter is set 0.0</p>

	<p>12 When the required configuration and settings are achieved, choose Preview from the top bar as shown in the picture, to compare the input video signal to the output</p>
	<p>13 The following page will be displayed</p>
	<p>14 Click on the Output button to view the output video signal next to the input video signal for comparison.</p> <p>Note: The user can select a group of parameters from the drop-down menu located at the left corner of the window called App, as shown below:</p> 

2. HDR Evie+ Audio settings

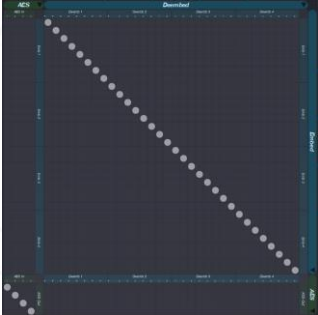

Perform the following steps to set up your greenMachine HDREvie audio Settings.

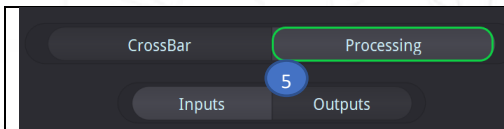
 	<p>1 Click on the Audio button</p> <p>2 The audio page is displayed on the screen</p>
 	<p>3 Click on crossbar</p> <p>4 The following options are displayed to the users. Click on the icon  if the audio is de-embedded from the input video signal or  if an AES input source is connected to the external audio interface female Sub-D 25 connector of greenMachine titan. The following picture shows the crossbar:</p> 



5 Click on **Processing** to change input and output audio settings



6 Select **Inputs** and click on the icon  if the audio is de-embedded from the video or  if the AES input is connected, to display the input settings. Adjust the audio parameters as required.

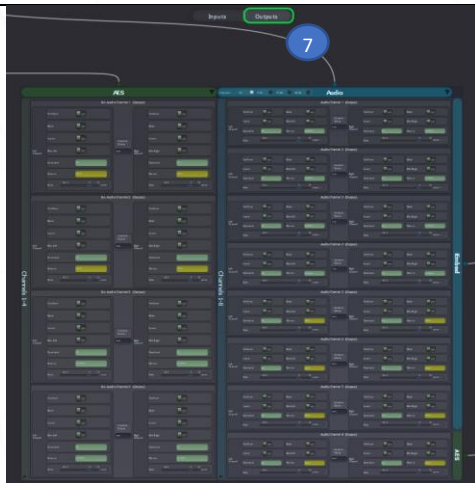

7 Select **Outputs** and adjust the audio parameters as required.

LYNXTechnik **AG**[®]
Broadcast Television Equipment