



Reference Manual

PEC 1864

3Gbit SDI/HDMI H.264 Streamer and Recorder

Revision 1.3 – Aug 2019

This manual supports PEC 1864 Version 1049 or higher

LYNXTechnik AG[®]
Broadcast Television Equipment

Information in this document is subject to change without notice. No part of this document may be reproduced or transmitted in any form or by any means, electronic or mechanical for any purpose, without express written permission of LYNX Technik AG.

LYNX Technik AG may have patents, patent applications, trademarks, copyrights or other intellectual property rights covering the subject matter in this document. Except as expressly written by LYNX Technik AG, the furnishing of this document does not give you any license to patents, trademarks, copyrights or other intellectual property of LYNX Technik AG or any of its affiliates.

Contents

Warranty	3
Regulatory information	4
Europe: Declaration of Conformity	4
USA: FCC 47 Part 15	4
Product Overview	5
Product Description	5
Functional Diagram	6
Connections and Local Controls	7
LED Description	8
Push Buttons	9
Micro SD Card	10
USB Interface	10
Supported Video Input Standards	11
SDI Input	11
HDMI Input	11
Audio Input	11
Power Specifications	12
Default IP Settings & Web UI Access	12
Web User Interface (Web UI)	13
Login Page	13
Main Page	14
System Settings	15
General Device Settings	15
Date / Time Settings	16
Factory Reset	16
Firmware Update	17
Network and Server Settings	18
Initial Setting of IP Address	19
Video Input Page	23
Analog Audio Input	24
Audio Input Settings	24
Audio Encoder Settings	24
Audio Deembedder	25
Video Processing	26
"Missing Input" Image	27
Encoder Page	29
Converter Settings	29
Encoder Settings	31
Text Overlay	31
Stream Page	32
Stream Settings	32
Streaming on YouTube	37
Recorder	38
Specifications	39
Technical Support	40
Contact Information	40

Warranty

LYNX Technik AG warrants that the product will be free from defects in materials and workmanship for a period of three (3) years from the date of shipment. If this product proves defective during the warranty period, LYNX Technik AG at its option will either repair the defective product without charge for parts and labor, or will provide a replacement in exchange for the defective product.

In order to obtain service under this warranty, customer must notify LYNX Technik AG of the defect before expiration of the warranty period and make suitable arrangements for the performance of service. Customer shall be responsible for packaging and shipping the defective product to the service center designated by LYNX Technik AG, with shipping charges prepaid. LYNX Technik AG shall pay for the return of the product to the customer if the shipment is within the country which the LYNX Technik AG service center is located. Customer shall be responsible for payment of all shipping charges, duties, taxes and any other charges for products returned to any other locations.

This warranty shall not apply to any defect, failure, or damage caused by improper use or improper or inadequate maintenance and care. LYNX Technik AG shall not be obligated to furnish service under this warranty a) to repair damage resulting from attempts by personnel other than LYNX Technik AG representatives to install, repair or service the product; b) to repair damage resulting from improper use or connection to incompatible equipment; c) to repair any damage or malfunction caused by the use of non-LYNX Technik AG supplies; or d) to service a product which has been modified or integrated with other products when the effect of such modification or integration increases the time or difficulty servicing the product.

THIS WARRANTY IS GIVEN BY LYNX TECHNIK AG WITH RESPECT TO THIS PRODUCT IN LIEU OF ANY OTHER WARRANTIES, EXPRESS OR IMPLIED. LYNX TECHNIK AG AND ITS VENDORS DISCLAIM ANY IMPLIED WARRANTIES OF MERCHANTABILITY OR FITNESS FOR A PARTICULAR PURPOSE. LYNX TECHNIK'S RESPONSIBILITY TO REPAIR AND REPLACE DEFECTIVE PRODUCTS IS THE SOLE AND EXCLUSIVE REMEDY PROVIDED TO THE CUSTOMER FOR BREACH OF THIS WARRANTY. LYNX TECHNIK AG AND ITS VENDORS WILL NOT BE LIABLE FOR ANY INDIRECT, SPECIAL, INCIDENTAL, OR CONSEQUENTIAL DAMAGES IRRESPECTIVE OF WHETHER LYNX TECHNIK AG OR THE VENDOR HAS ADVANCE NOTICE OF THE POSSIBILITY OF SUCH DAMAGES.

Regulatory information

Europe: Declaration of Conformity

We	LYNX Technik AG Brunnenweg 3 D-64331 Weiterstadt Germany
<i>Declare under our sole responsibility that the product</i>	
TYPE: PEC 1864	
<i>To which this declaration relates is in conformity with the following standards (environments E1-E3):</i>	
EN 55103-1 /1996	
EN 55103-2 /1996	
EN 60950-1 /2006	
<i>Following the provisions of 2014/30/EU and 2014/35/EU directives.</i>	
	Winfried Deckelmann
Weiterstadt, May 2017	
<i>Place and date of issue</i>	<i>Legal Signature</i>

USA: FCC 47 Part 15

This device complies with part 15 of the FCC Rules. Operation is subject to the following two conditions: (1) This device may not cause harmful interference, and (2) this device must accept any interference received, including interference that may cause undesired operation.

Note: This equipment has been tested and found to comply with the limits for a Class A digital device, pursuant to the part 15 of the FCC Rules. These limits are designed to provide reasonable protection against harmful interference when the equipment is operated in a commercial environment. This equipment generates, uses, and can radiate radio frequency energy and, if not installed and used in accordance with the instruction manual, may cause harmful interference to radio communications. Operation of this equipment in a residential area is likely to cause harmful interference in which case the users will be required to correct the interference at their own expense.

Product Overview

Product Description

The PEC 1864 is a versatile, compact SDI/HDMI H.264 streamer and recorder designed for a wide range of applications in the broadcast, film and pro AV industry.

The module can be configured to stream, record or to do both simultaneously. The streamer and recorder have independent encoders allowing for separate configuration of streaming and recording. Each encoder includes an up/down/cross converter, region of interest scaler and a text overlay feature.

Two channels of audio are de-embedded from the video input. In addition, the PEC 1864 has a line audio input and either one of these audio sources can be used for the streamer and/or recorder.

Users can insert a logo into the video signal stream, which can be positioned anywhere in the image. Also, in the event of an input failure a user defined image can be used.

The PEC 1864 supports a wide range of streaming standards as well as unicast and multicast modes of operation. Whether you are streaming live to a Content Delivery Network using RTMP, viewing the stream on one or more computers using RTP/RTSP unicast or multicast, or streaming to a dedicated decoder or multicast address using TS over UDP or RTP, the PEC 1864 is a powerful device ideal for a diverse range of applications.

The PEC 1864 is ideal for live event streaming, webcasts, corporate or enterprise streaming, presentation and conferencing, AV system monitoring, house of worship proceedings streaming and many more applications.

The module has an intuitive Web-based user interface used for control, set up and configuration from a PC, Mac, tablet or smartphone.

Functional Diagram

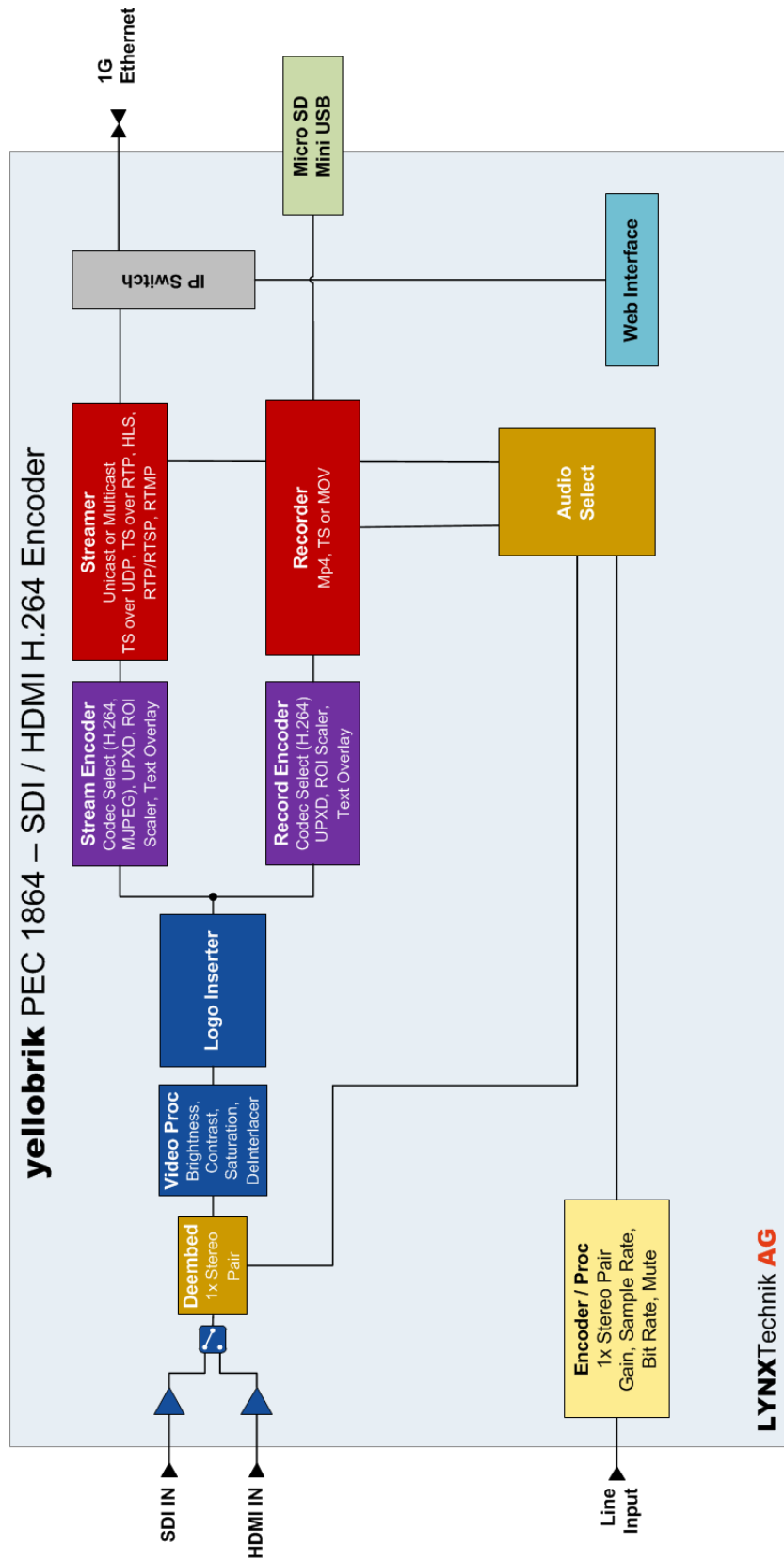

Connections and Local Controls

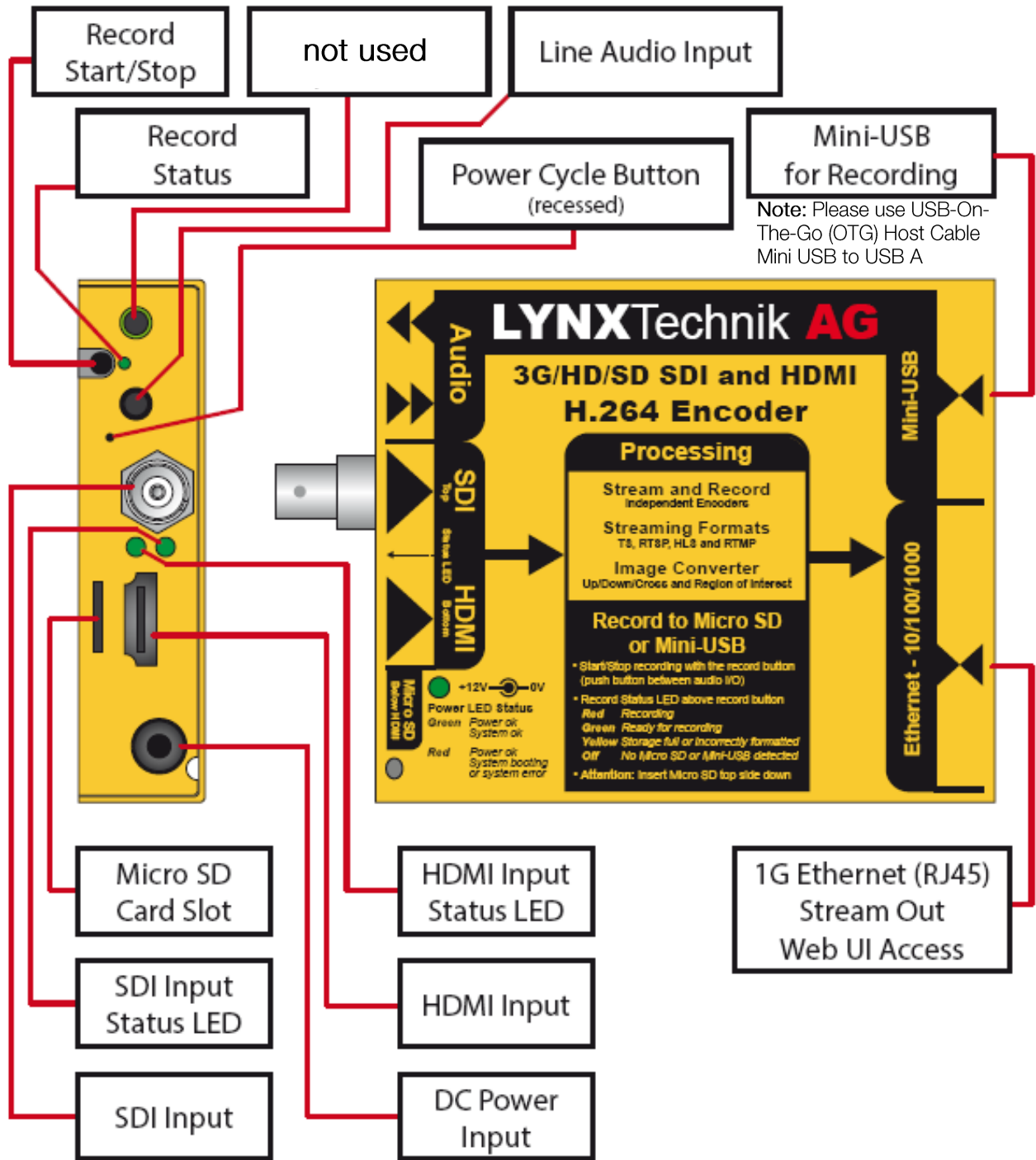

LED Description

Record LED

- LED OFF = No Micro SD card or USB device detected
- LED green = Micro SD card or USB device detected and ready for recording
- LED yellow = Micro SD card or USB device detected but incorrect formatting or full
- LED red = Recording in progress

SDI and HDMI LED

The input detection for SDI and HDMI works independently from each other i.e. the LED status for SDI (top) and HDMI (bottom) will work regardless if the respective input is being used for encoding:

- LED OFF = No signal detected
- LED green = Valid video input detected

Power LED

- LED OFF = Module not powered
- LED green = Module powered and system okay
- LED red = Reboot or system failure

LAN LED

- Yellow LED flashing = 100Mbit; flashing => activity
- Green LED On = 1Gbit; flashing => activity

Push Buttons

Record Button

- Pressing the record button will start the recording if the record LED is green (i.e. Micro SD card or USB device detected and ready for recording).
- Pressing the record button will stop the recording if the record LED is red (i.e. recording in progress).
- Pressing the record button if the record LED is OFF (no Micro SD card or USB device detected) or yellow (Micro SD card or USB device detected but incorrect formatting or full) will result in no action.

Note: For MOV and MP4 recording type the record time is limited to 4 hours

Recessed Power Cycle Button

- Pressing the recessed power cycle button will result in a power cycle of the module.

Factory Reset

There are three ways to reset the module back to its factory defaults.

Note. This will reset ALL settings including the IP address

1. Factory Reset: Using the Record Button

- The record push button can be used to reset the module to factory defaults
 - Press the record button and the LED will flash GREEN once
 - Continue to keep the record button depressed for about 10 seconds and the LED will flash GREEN a second time
 - Release the record button

The module is now reset to factory defaults

2. Factory Reset: Record Button + Power Cycle

- Power cycling the module while pressing and holding the record push button will result in a reset to factory defaults
 - Press and hold the RECORD button
 - Power Cycle the module (while holding the record button)
 - Keep record button depressed until record LED turns RED

The module is now reset to factory defaults

3. Factory Reset: Using the Web UI

- The module can also be reset to factory defaults using the “factory Reset” command in the Web UI

Micro SD Card

Recommended Micro SD card

- Micro SDHC (SD 2.0)
- Maximum size: 32GB
- We recommend Speed class 10 (for 3G high quality recording)

Supported Formats

- FAT32
- NTFS 3.1
- exFAT

USB Interface

USB Specifications

- Mini A/B USB
- USB 2.0
- Maximum size: 32GB

Supported Formats

- FAT32
- NTFS 3.1
- exFAT

Note: Please use USB-On-The-Go (OTG) Host Cable Mini USB to USB A

Supported Video Input Standards

SDI Input

SMPTE 259M (SDTV)

- 525
- 625

SMPTE 292M (1.5G HDTV)

- 720p 23/24/25/29/30/50/59/60Hz
- 1080i 50/59/60Hz
- 1080p 23/24/25/29/30Hz
- 1080psF 23/24/25Hz

SMPTE 424M (3G HDTV)

- 1080p 50/59/60Hz (Level A)

HDMI Input

The HDMI input of the PEC 1864 can accept video signals according to EIA/CEA-861-D.

- 525
- 625
- 480p 59.94Hz
- 576p 50Hz
- 720p 23/24/25/29/30/50/59/60Hz
- 1080i 50/59/60Hz
- 1080p 23/24/25/29/30Hz
- 1080p 50/59/60Hz

- VGA (640x480)
- SVGA (800x600)
- XGA (1024x768)
- WXGA (1280x768)
- WUXGA (1920x1200)

Audio Input

1x 3.5mm stereo jack

- Unbalanced
- AC-coupled
- 10kOhm

Power Specifications

- Power Input: 12VDC
- Power Consumption: 3.2W @ 12V nominal
- Power Input Range: 5V - 14V

Default IP Settings & Web UI Access

- IP Address: 192.168.1.161
- Netmask: 255.255.255.0
- Broadcast: 192.168.1.255
- Gateway: 192.168.1.1
- **Web-UI access**
Password: yellobrik\$admin

Web User Interface (Web UI)

The Web User Interface (Web UI) is an easy and intuitive way to configure the PEC 1864. The Web UI was specifically designed as a mobile friendly application. Therefore, it can also be displayed and used with a tablet or smartphone.

Note: There is no yelloGUI application available

Supported browsers:

- Firefox Version 45 (v44 and older are not supported)
- Chrome Version 57
- Safari Version 10
- Microsoft Edge 13

Note: Microsoft browser Internet Explorer is not supported

Login Page

The Login Page requests the user to enter a password and offers the possibility to remember the password in a cookie stored in the browser cache. The login is executed when the user presses the Login button.



Main Page

The main page of the Web UI shows the basic functional signal diagram of the module. To access more detailed settings, the user simply clicks on the respective functional block.



To get back to the Main Page there is a return button at the left upper corner of all pages.

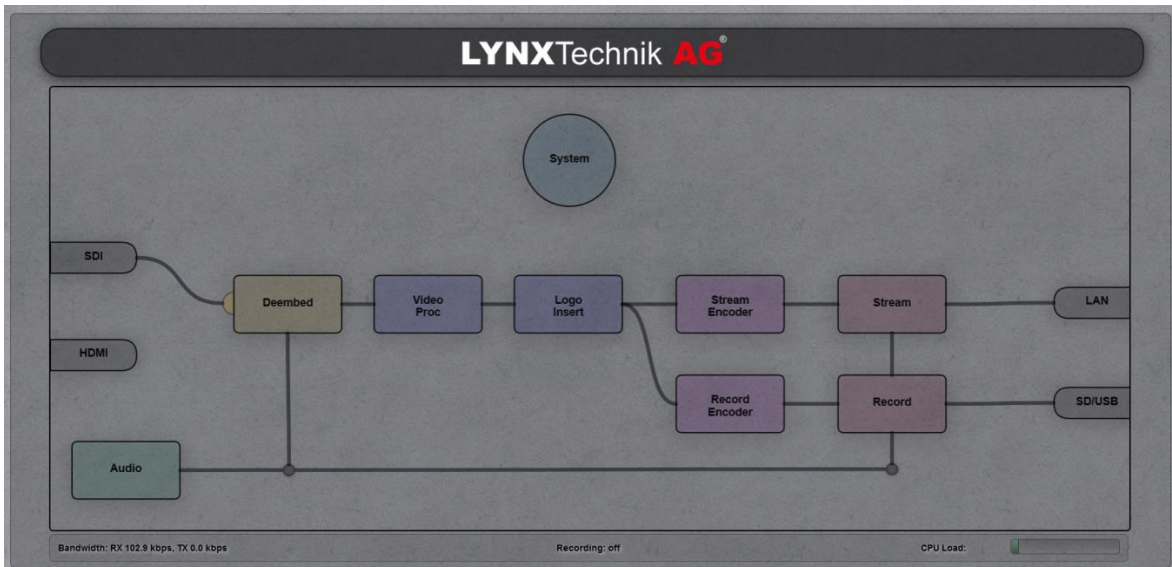

The main page also has the following system status information at the bottom of this page:

- RX Bandwidth
- TX Bandwidth
- Recording Status
- CPU Load

This system status information provides an indication whether the configuration will result in a working output.

System Settings

On this page the system settings of the PEC 1864 including the IP address and date / time can be modified. Information about the SW version can also be found and a module update can be executed.

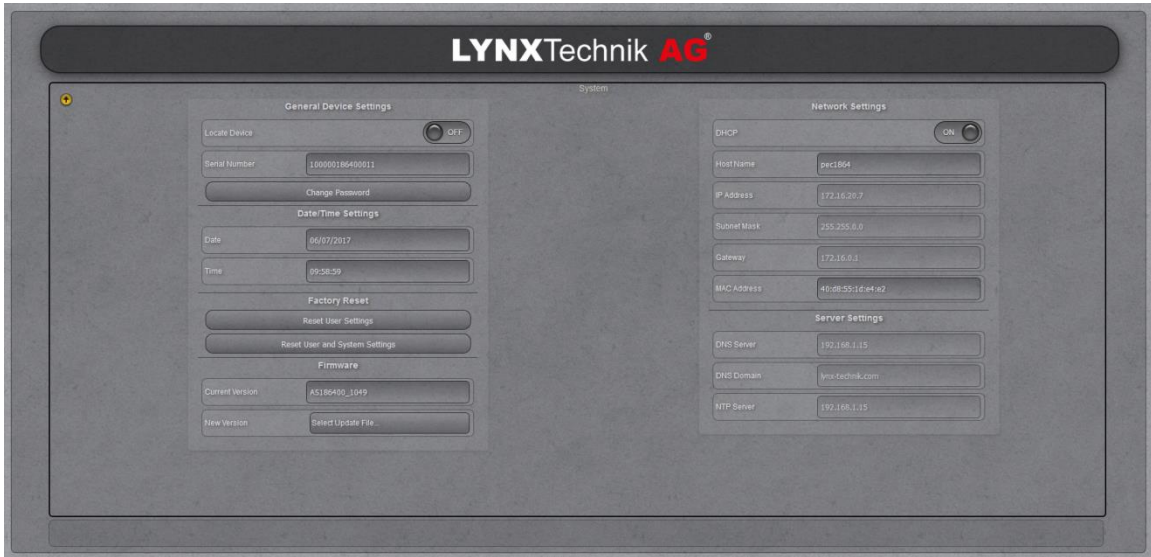

General Device Settings



- Locate device: If ON the LEDs on the PEC 1864 will flash.
- Change password: Clicking this button will open a pop-up menu requesting a double entry of a new password.

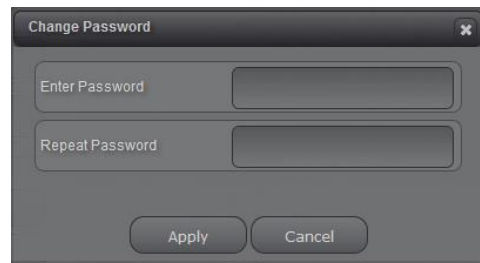

Date / Time Settings

The user can define a Date and Time. This information can be inserted as text into the video stream.

Note: The PEC 1864 does not have a battery; this information survives a short power cycle only

The Date and Time information can also be taken from an NTP server. The NTP server mode is activated as soon as a NTP server address is typed into the respective field in the Web UI (see page 18).

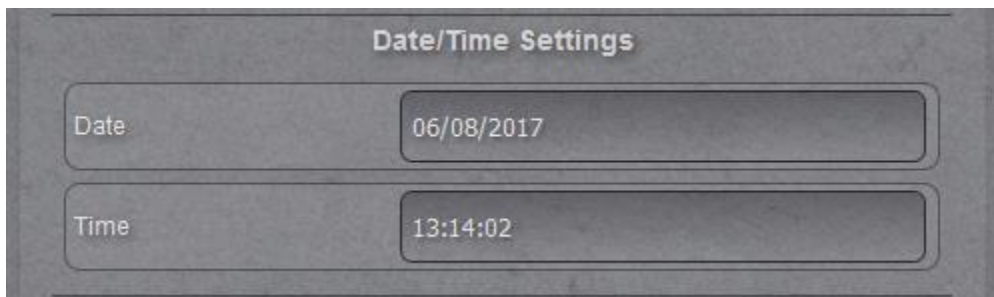

The screenshot shows a web interface titled "Date/Time Settings". It contains two input fields. The first field is labeled "Date" and contains the text "06/08/2017". The second field is labeled "Time" and contains the text "13:14:02".

- Date: MM/DD/YYYY (Default = empty) – read only if NTP mode is activated
- Time: HH:MM:SS (Default = empty) - read only if NTP mode is activated

Factory Reset



The screenshot shows a web interface titled "Factory Reset". It contains two buttons. The first button is labeled "Reset User Settings". The second button is labeled "Reset User and System Settings".

Reset User Settings: Only the Signal Processing Parameters are set back to factory default

Reset User and System Settings: In addition, all IP-related parameters incl. the Web UI password will be set back to factory default

Note: You can execute the reset to factory defaults (reset User and System Settings) also on the PEC 1864 itself

Firmware Update

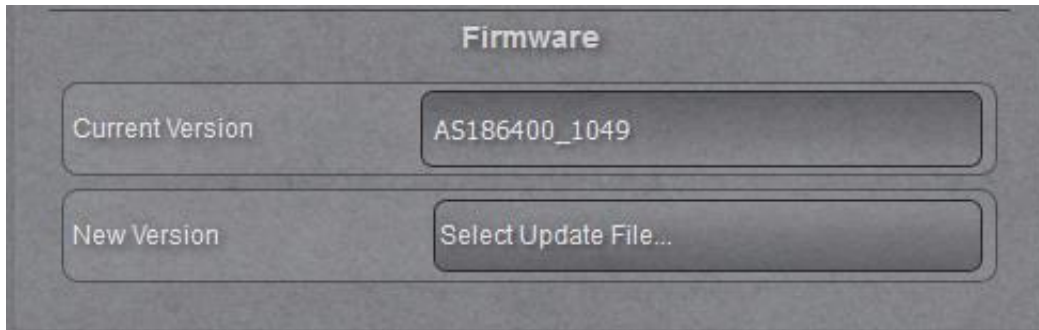

Current Version: Displays the SW version that the PEC 1864 is running.

New Version: Clicking this button will open a file browser, allowing you to select an LXZ file.

To update the module to a new version the Update file must be on the computer of the user. The update file can be downloaded from the LYNX website:

www.lynx-technik.com > Support > Download Area > yellobrik Firmware

As soon as an update file is selected an update button will appear.

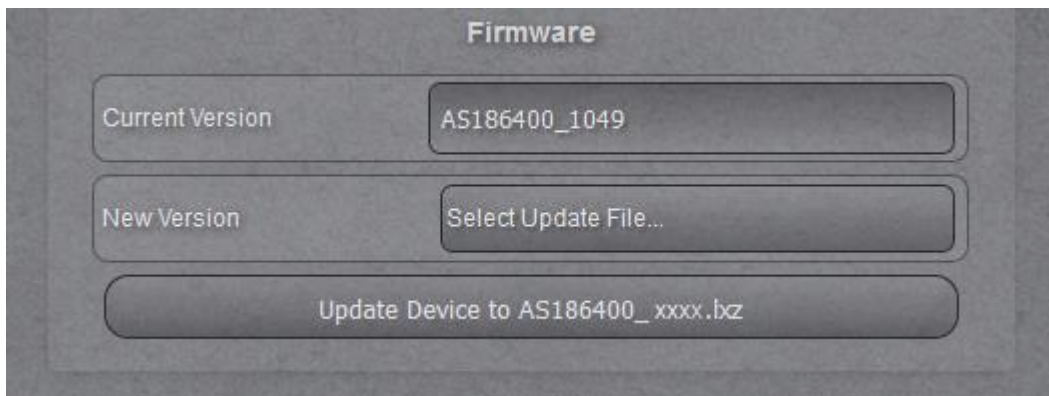

Clicking on this update button will start the update process.

Network and Server Settings

In this section the user can modify the network and Server settings.

Setting	Default
• DHCP: ON, OFF	OFF
• Host Name: Text	PEC1864
• IP Address	192.168.1.161 - read only if DHCP is activated
• Subnet Mask	255.255.255.0 - read only if DHCP is activated
• Gateway	192.168.1.1 - read only if DHCP is activated
• MAC Address	(xx:xx:xx:xx:xx) - read only
• DNS Server	0.0.0.0 - read only if DHCP is activated
• DNS Domain	empty - read only if DHCP is activated
• NTP Server IP	0.0.0.0 - read only if DHCP is activated

Note: For RTMP streaming to a server in the public internet a correct DNS configuration is necessary.

Initial Setting of IP Address

The PEC 1864 is delivered with a fixed IP address (192.168.1.161).

To use the PEC 1864 in your network you need to change the IP address to fit your local requirements. To get direct access from your computer to the PEC 1864, i.e. a cable in between the PEC 1864 and your computer, you need to set the IP settings of your computer accordingly. After you have modified the IP settings of the PEC 1864 you can set back your computer to the original IP settings.

Windows 7 or Windows 8.x or Windows 10

To change the computer's IP address in Windows, type *network and sharing* into the Search box in the Start Menu and select Network and Sharing Center when it comes up. If you are in Windows 8.x it will be on the Start Screen itself, like the screenshot at the top of this article. If you're in Windows 7 or 10 it'll be in the start menu.

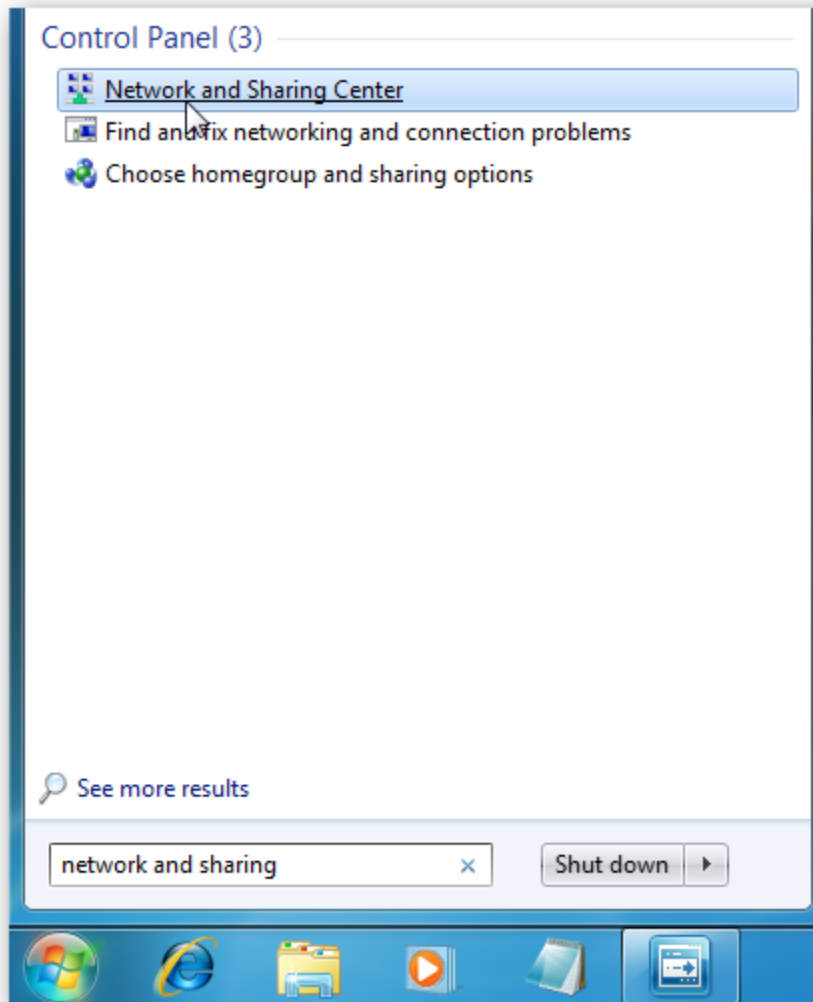

When the Network and Sharing Center opens, click on *Change adapter settings*. This will be the same on Windows 7 or 8.x or 10.

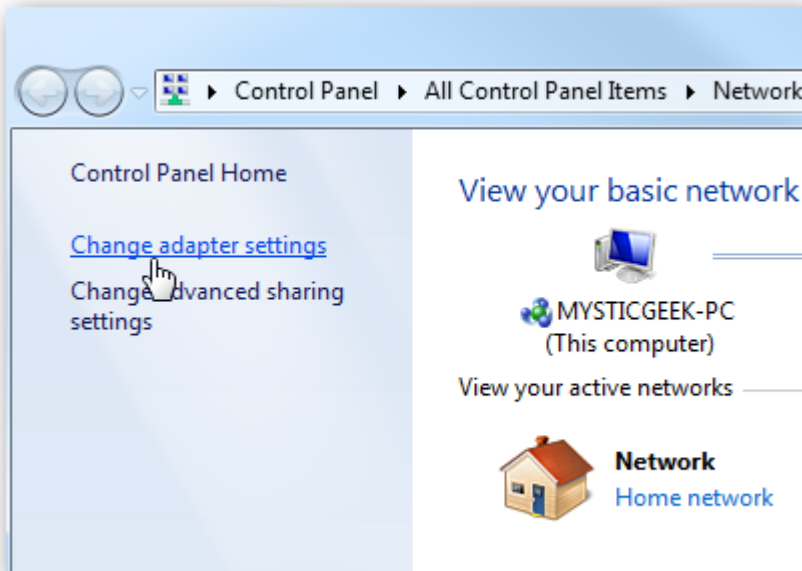

Right-click on your local adapter and select Properties.

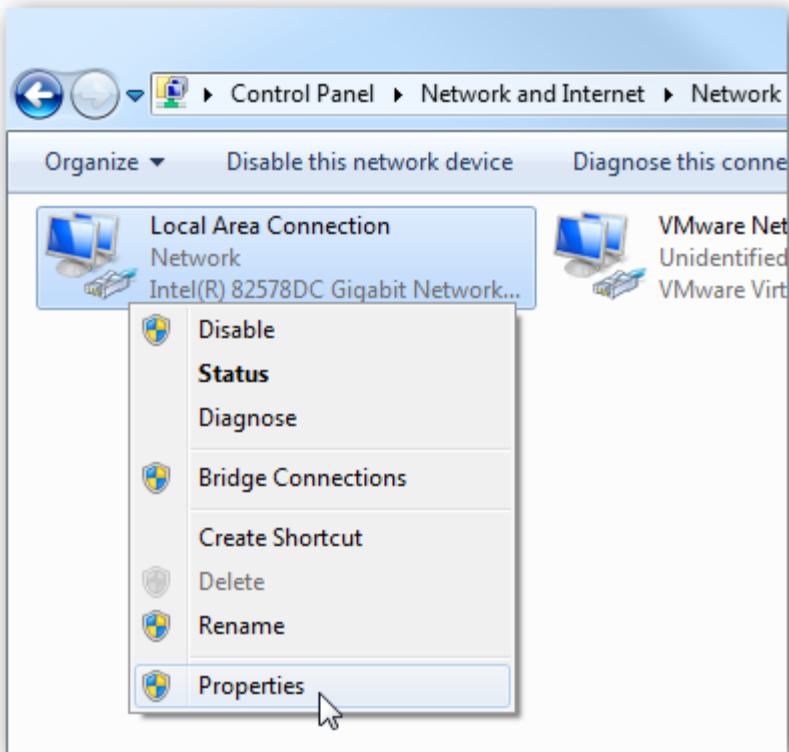

In the Local Area Connection Properties window highlight *Internet Protocol Version 4 (TCP/IPv4)* then click the Properties button.

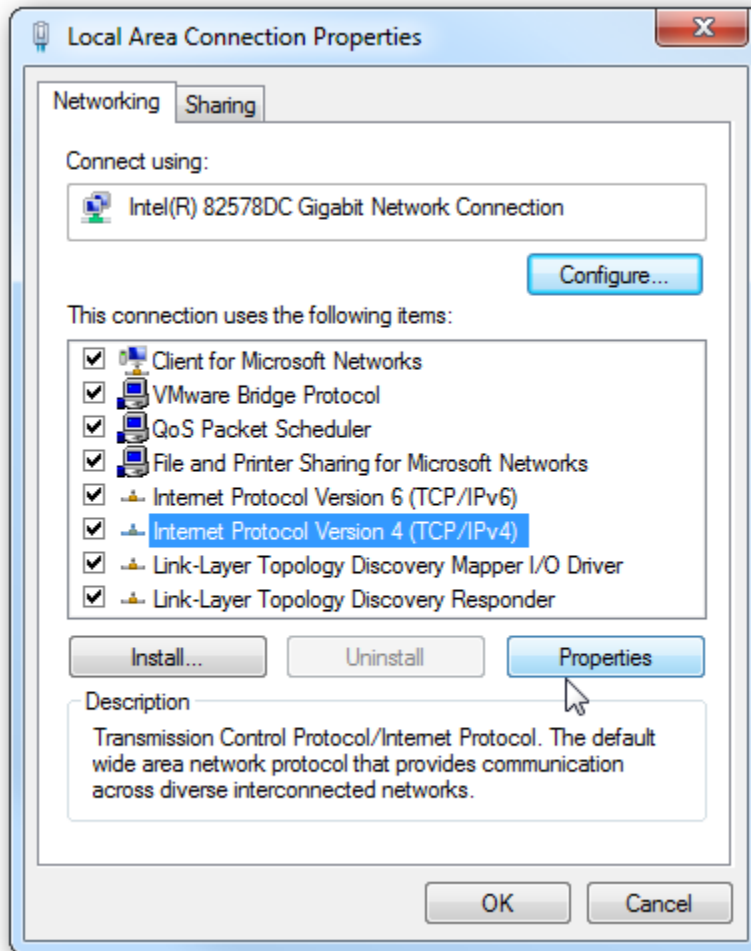

Now select the radio button *Use the following IP address* and enter in the correct IP and Subnet mask, and Default gateway that corresponds with your network setup. Check *Validate settings upon exit* so Windows can find any problems with the addresses you entered. Then click OK.

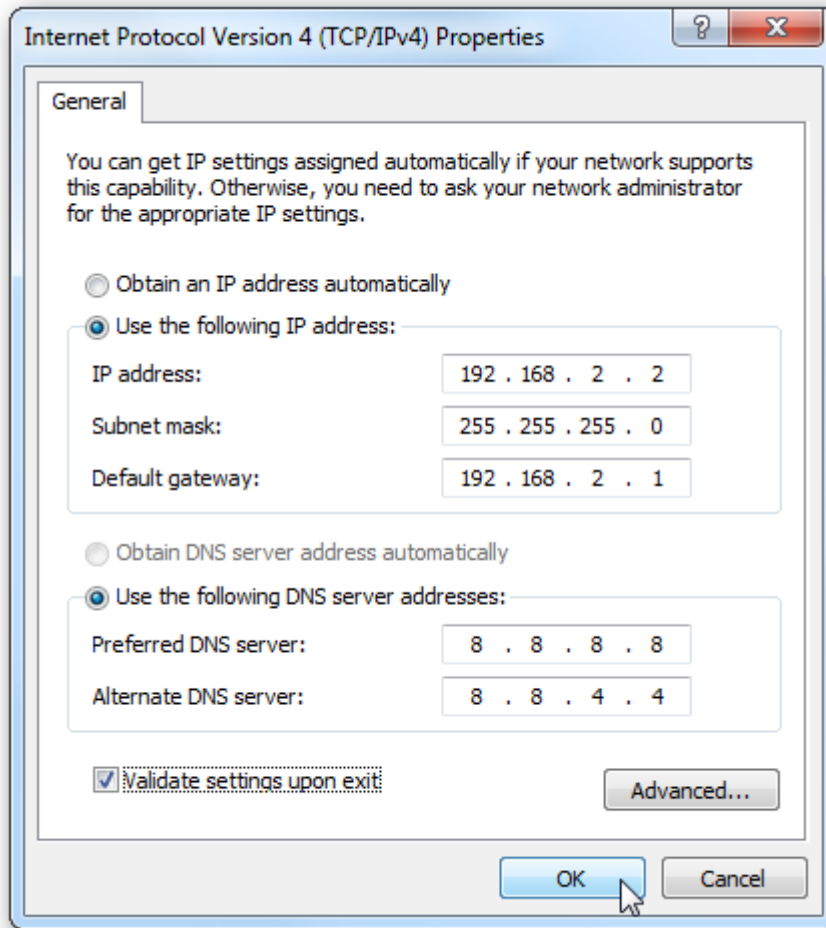

Please set the IP address to 192.168.1.x

and the Subnet Mask to 255.255.255.0

Note: The DNS settings are not important for this purpose and can stay as they are

Video Input Page

On the left side of the main page is the representation of the SDI and HDMI inputs. The background color of the label will change according to the input LED status of each input.

- Grey = No signal detected
- Green = Valid video input detected

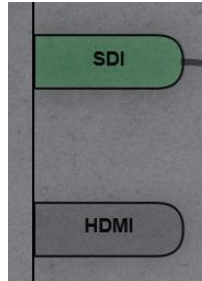

As the PEC 1864 only processes either the SDI or HDMI input, the user can select the input by dragging & dropping the signal path. The input signal can also be selected on the deembedder page (see page 21).

To get more information about the input signals, a double click on the respective input label will open the Video Input page of the Web UI.

The Video Input page shows the video standard (spatial resolution and frame rate) of the connected input signal. In case of SDI input it also shows the audio groups present in the input signal.

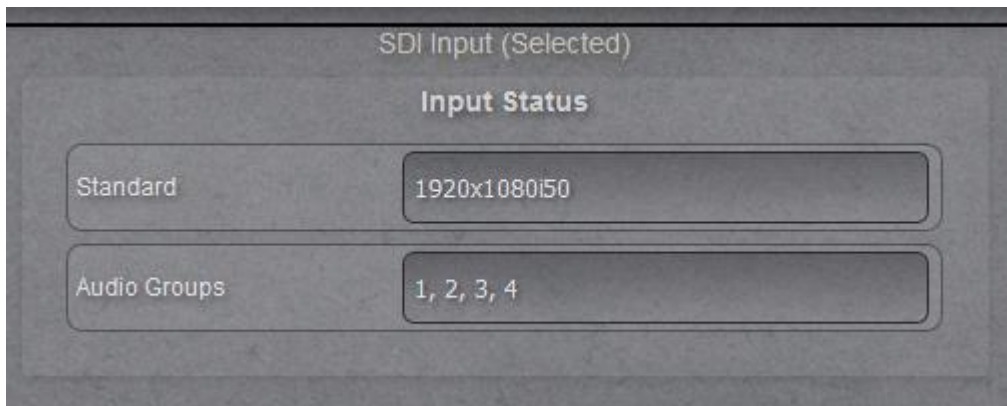

Analog Audio Input

A 3.5mm stereo jack connector next to the BNC video connector is a stereo audio input for line level signals.

The following settings are available in the Web UI:

Audio Input Settings

- Sample Rate: kHz 8, 16, 32, 44.1, 48 (Default = 48kHz)
- Gain: -34.5dB to 33.0dB, increment 1.5dB (Default = 0 dB)
- Mute: ON, OFF (Default = OFF)

Audio Encoder Settings

- Audio Codec: AAC (Display only)
- Bitrate: 8kbps to MAX (Default = 128kbps): MAX = 9x Audio Sample Rate



Audio Deembedder

One stereo pair of the SDI or HDMI video input can be selected to be deembedded (8 pairs are available for SDI, 4 pairs for HDMI). The selected audio is available for use in the encoders.



An additional setting is available to configure the behavior on loss of input. The selection for this parameter is "Off", "Silence" or "1kHz Test Tone".



Video Processing

The following settings are available in the video processing stage:

Parameter	Range	Default
Color Settings		
Brightness	-128 to +128	0
Contrast	-128 to +128	0
Saturation	-128 to +128	0
Missing Input Handling		
Force Missing	ON, OFF	OFF
Missing Input	OFF, Colorbar, Grey, Black, Image	Colorbar
Deinterlacer		
Deinterlace	OF, OFF	OFF

Note: The deinterlacer will introduce an additional delay of 100-200ms

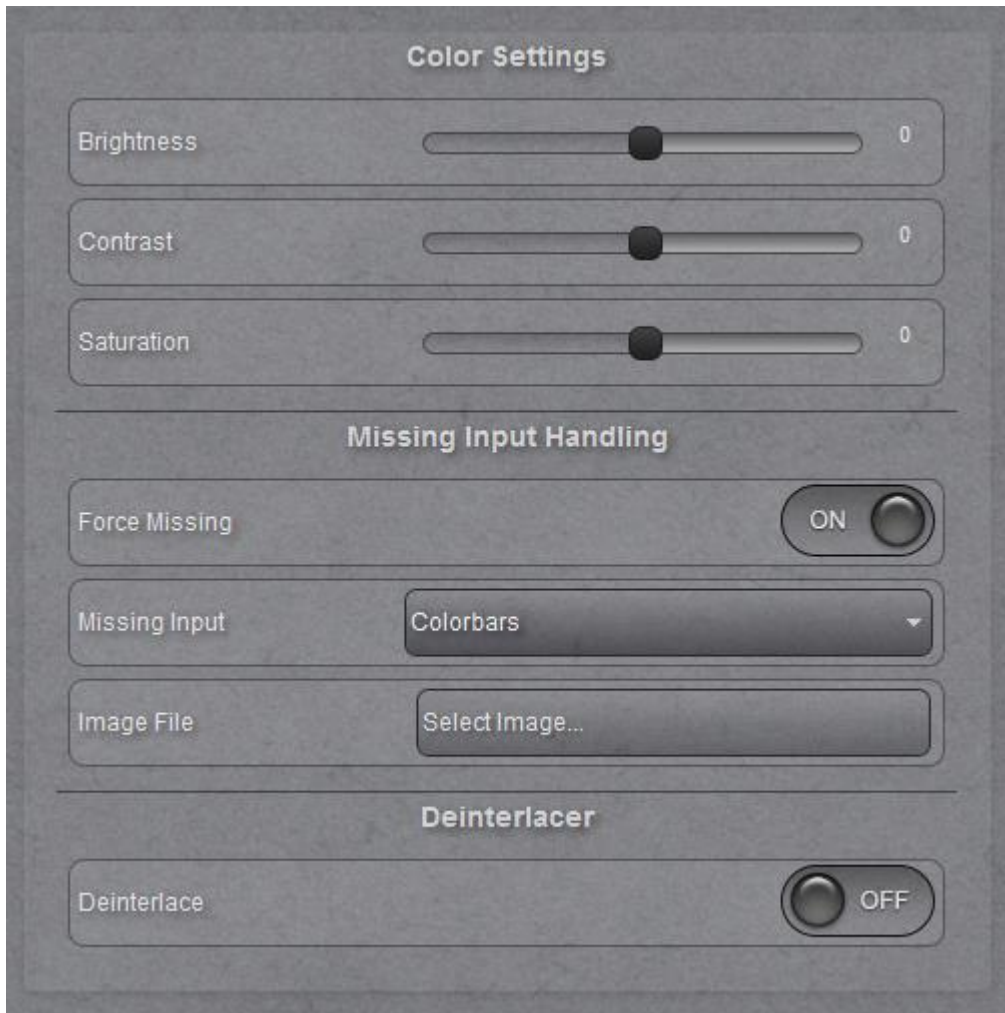

Note: Double clicking on the sliders will reset the respective parameter to factory default

"Missing Input" Image

When the above mentioned "Missing Input" parameter is set to "Image," an uploaded custom image will be output if the input signal is missing or "Force Missing" is ON.

Use the "Image File" button to select and upload an image.

It's only possible to upload one image file i.e. uploading a new file will replace the existing one. The image needs to comply with the following specifications:

- Supported formats are JPG, BMP, GIF, PNG
- The resolution of the image needs to match the resolution of the video input signal. The image is not resized and is centered in the output stream.

When a "Missing Input" image has been uploaded to the PEC 1864, the window on the right side of the Web UI will show a small preview of this image:

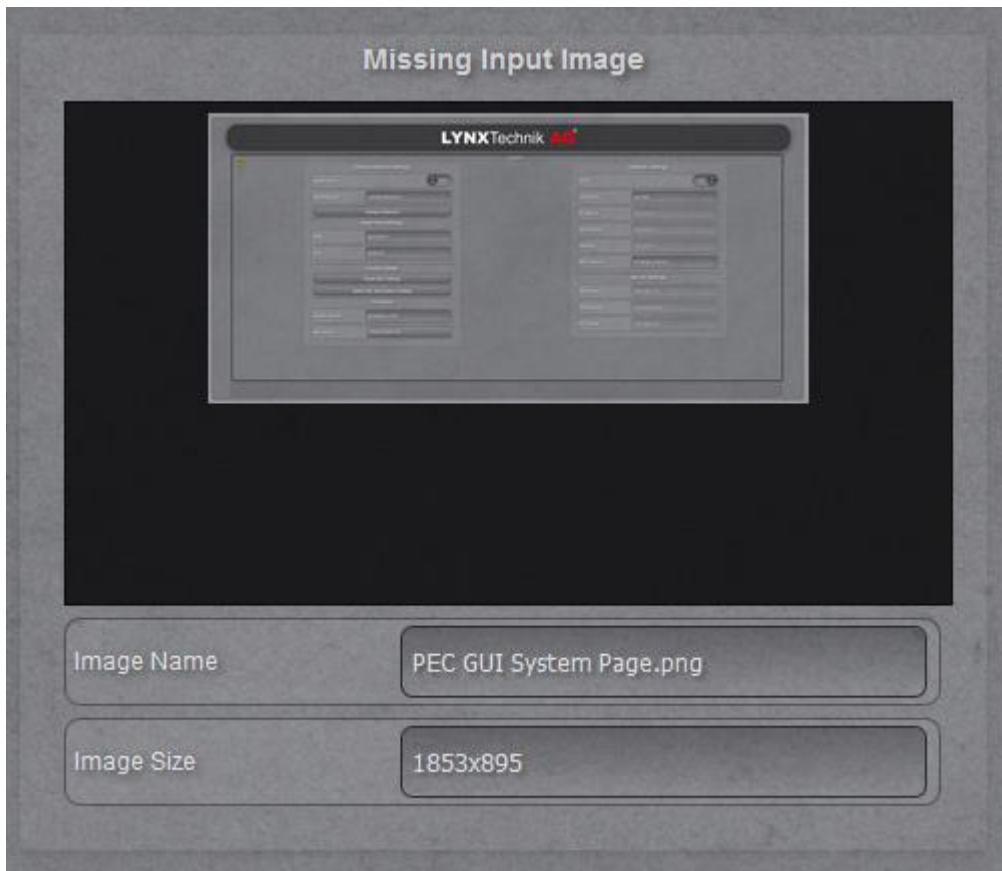

Logo Insertion

The PEC 1864 includes a logo inserter. The logo is inserted before the encoders i.e. when inserted, the logo will be on both outputs in the same position.

Use the "Image File" button to select and upload the logo file.

It's only possible to upload one logo file i.e. uploading a new file will replace the existing one.

The logo image is not resized. Therefore, the same logo file will be bigger or smaller for different input resolutions. The image needs to comply with the following specifications:

- Supported formats are JPG, BMP, GIF, PNG
- Only PNG and GIF support transparency
- The filename needs to be lower case letters (no caps, spaces or special characters) and can be a maximum of 20 characters long
- The file has a maximum of 16 colors
- The width of the image needs to be divisible by four
- The image must not exceed 16,000 pixels when calculated with the following formula:
 - $(width + 12) * height + 24 \leq 16,000$

Once the logo has been uploaded the following controls are available:

- Insert Logo (On, Off) [Default = Off]
- X-Position (0 to max. horizontal resolution of detected video input) [Default = 0]
- Y-Position (0 to max. vertical resolution of detected video input) [Default = 0]

Note: The positioning of the logo is based on the top left corner of the logo image. The origin of the X/Y positioning is the top left corner of the video signal. In other words, when X and Y position is set to "0" the logo will be in the top left corner.

Note: When a logo has been uploaded to the PEC 1864, the window on the right side of the Web UI will show a preview of the logo.



Encoder Page

Converter Settings

The PEC 1864 has two separate encoders; one for the streaming output and one for recording. Both encoders have identical functions (except for MJPEG which is not available for the recording encoder) and work independently from each other.

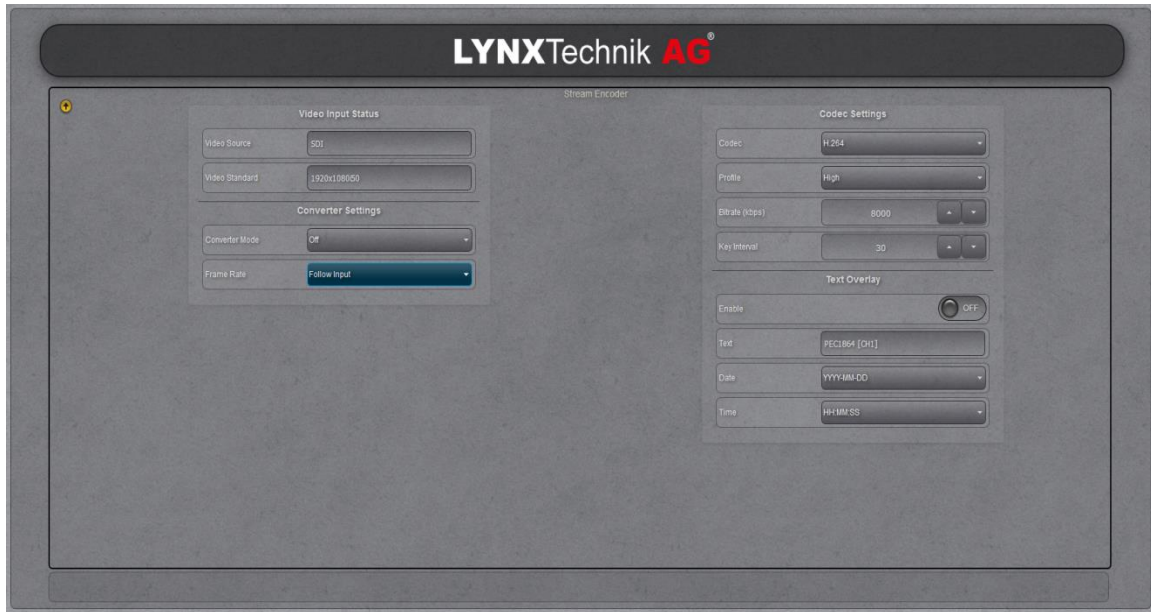

On the encoder page the user can also find information about the Video Input status and the Converter settings can be defined:

- Video Source: Shows the selected video input (display only)
- Video Standard: Shows the detected video input resolution (display only)
- Converter Mode: OFF, Stretch to Fill, Center-Cut, Custom ROI (Default = OFF)
- Output Frame Rate: Follow Input, 10-60fps (Default = Follow Input)

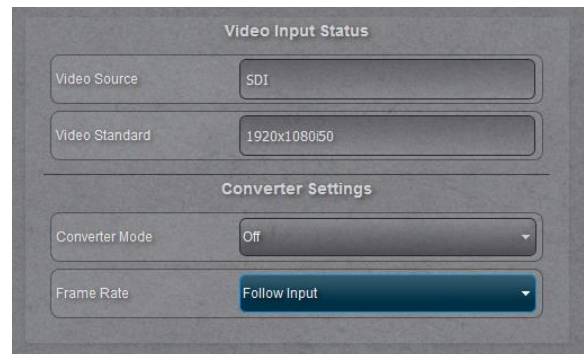

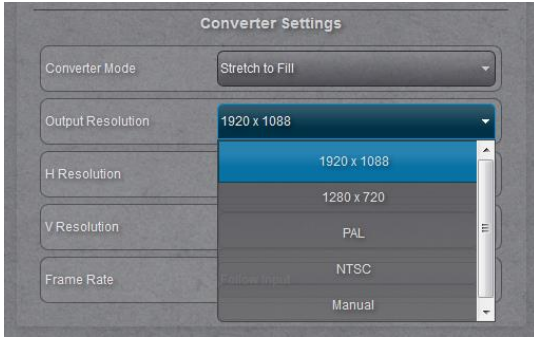

If one of the converter modes is selected, the output resolution can be set: 1920x1088, 1280x720, NTSC, PAL, Manual (Default = 1920x1088)

If Manual is selected the resolution can be set horizontally (H Resolution) and vertically (V Resolution).

Note: The output resolution follows the input signal if the converter is switched off.

"Stretch to Fill" scales the whole input image to the selected resolution and modifies the pixel aspect ratio if necessary.

"Center-Cut" crops the largest possible area of the input image which matches the aspect ratio of the output resolution and scales that region accordingly.

"Custom ROI" crops the specified area of the input images and scales it to the output resolution.

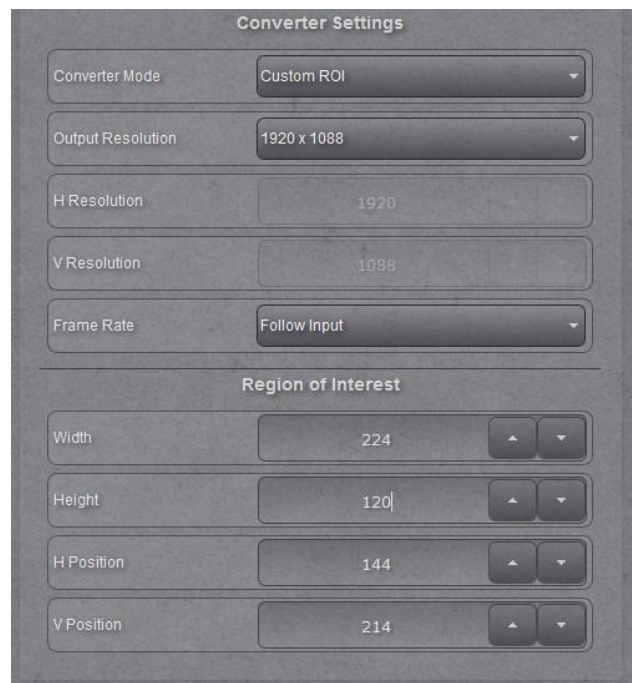

Encoder Settings

The main setting determines which codec is used. Depending if H.264 or MJPEG is selected as the codec, the available controls vary slightly.

Note: MJPEG is only available for RTSP streaming format

The following settings are available when H.264 codec is selected:

- Profile: Baseline, Main, High (Default = High)
- Bitrate: 200 to 16.000kbps (Default = 8.000kbps)
- Key Interval: 1 to 500 (Default = 30)

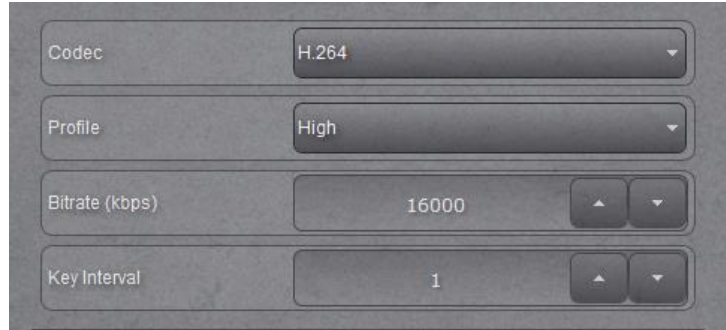

If the MJPEG codec is selected the Quantization Value can be set.

Text Overlay

The encoder also includes a text overlay.

The user has the following overlay functions:

- Overlay: ON, OFF (Default = OFF)
- Overlay Text (text entry field)
- Date: None, YYYY-MM-DD, MM/DD/YYYY, DD.MM.YYYY (Default = None)
- Time: None, HH:MM, HH:MM:SS (Default = None)

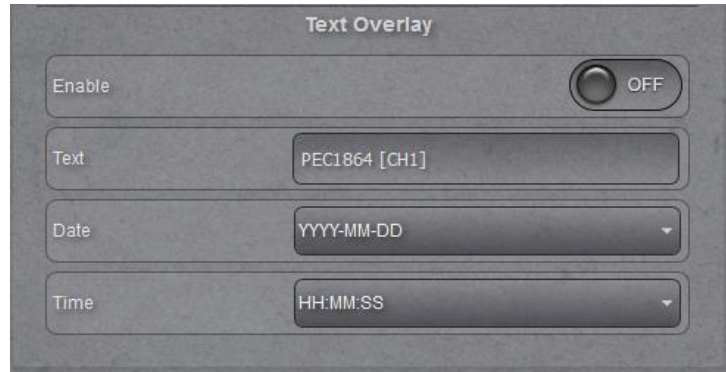

Note: max. number of characters (including date and time) is 63

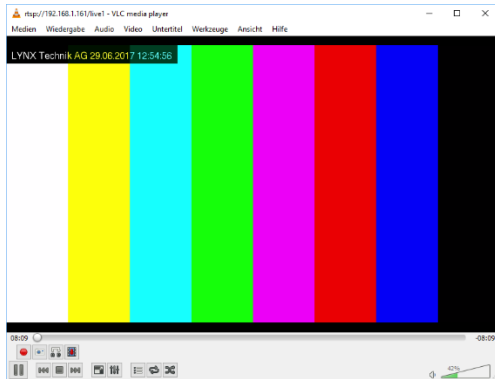

The text is positioned in the left upper corner. Overlay text first, then date and time. All is displayed in one line.

Stream Page

The configurations for the streamer can be set in a flexible way on the Stream Page (see below)

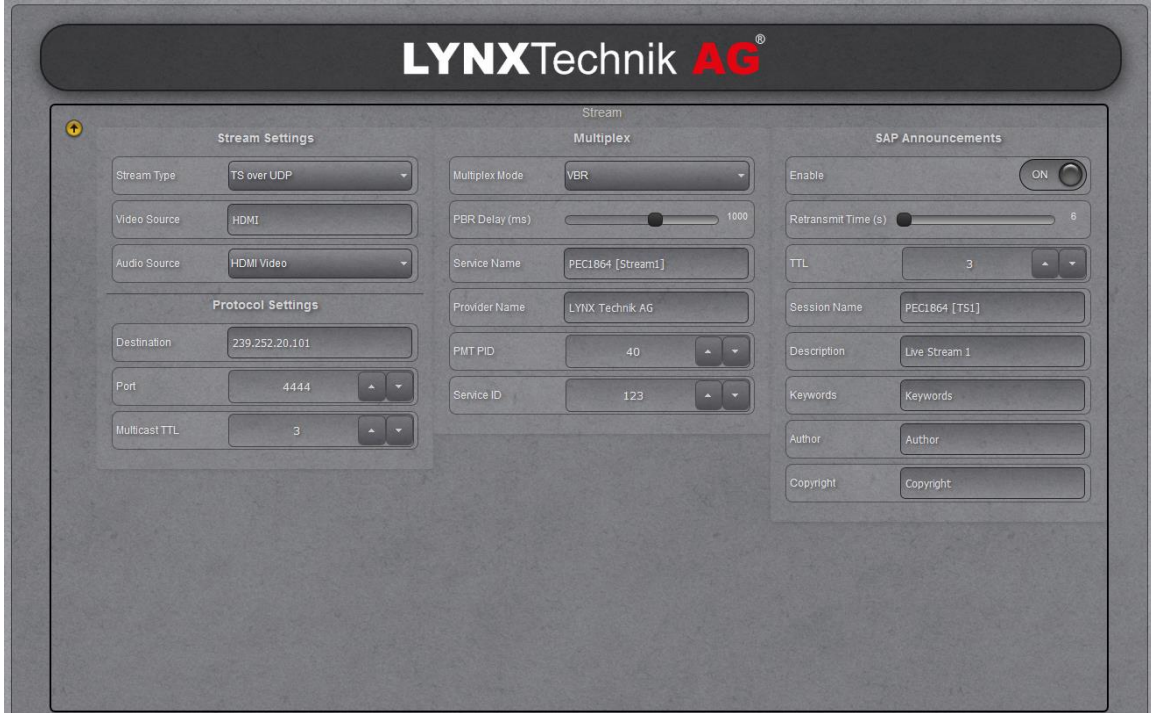

Stream Settings

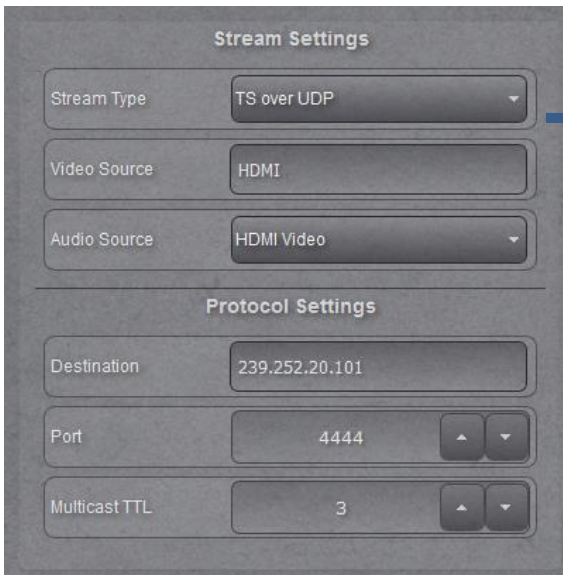

The PEC 1864 supports different streaming formats.

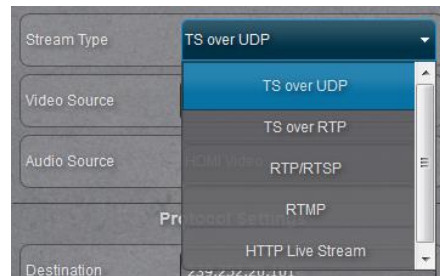

Stream Types: TS over UDP, TS over RTP, RTP/RTSP, RTMP, HLS (Default = RTMP)

- Video Source (Display only)
- Audio Source: Off (no audio), HDMI Video, SDI Video, Analog Audio Input
Default = Selected Video Input



The Stream settings are different for the different streaming formats.

TS over UDP

Transport stream over UDP is used to stream a signal to a dedicated IP address using the UDP protocol which can be a specific decoder or a multicast IP address. The PEC 1864 allows the user to add a session announcement protocol (SAP) to the stream.

The following settings are available (in addition to the global streamer settings):

Protocol Settings

- Destination IP address
(Default = 239.252.20.101)
- Port: 1-65535
(Default = 4444)
- Multicast TTL (Time To Live): 1-255
(Default = 3)
Note: Multicast TTL is the max. number of routers the stream can pass



Multiplex Settings

- Multiplex Mode: CBR, VBR, RVBR
(Default = VBR)
- Multiplex Bitrate: 200kbps to 50Mbps
(Default = 8Mbps)
- PBR delay: 300ms to 1500ms
(Default = 1000ms)
- Service Name: free text
(Default = PEC1864 [Stream1])
- Provider Name: free text
(Default = LYNX Technik AG)
- PMT PID: 17 to 8190 (Default = 40)
- Service ID: 123 to 8765 (Default = 200)

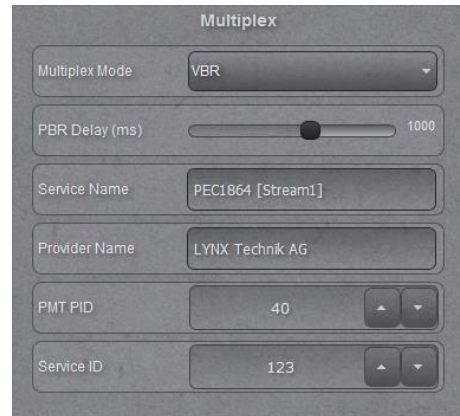

Note: *CBR: Constant Bitrate; VBR: Variable Bitrate; RVBR: Restricted Variable Bitrate (limited upper bandwidth; PBR: Policy Based Routing; PMT: Program Map Table*

SAP Settings

- Enable SAP: ON, OFF
(Default = OFF)
- TTL: 1-255
(Default = 3)
- Retransmit Time: 1 – 1000s
(Default = 6s)
- Session Name: Free text
(Default = PEC1864 [TS1])
- Description: Free text
(Default = Live Stream 1)
- Keywords: Free text
(Default = Keywords)
- SAP Author: Free text
(Default = Author)
- Copyright: Free text
(Default = Copyright)



TS over RTP

Transport stream over RTP is used to stream a signal to a dedicated IP address using the RTP protocol which can be a specific decoder or a multicast IP address. The PEC 1864 allows the user to add a session announcement protocol (SAP) to the stream.

This streaming mode has the same parameters as TS over UDP, plus the following:

- Forward Error Correction: ON, OFF
(Default = OFF)

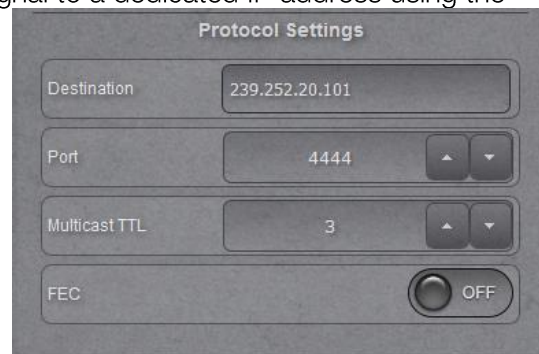

RTP/RTSP

RTP/RTSP is used to stream a signal to a dedicated IP address or a multicast address using the Real-Time Streaming Protocol.

The following RTSP settings are available:

- Access Name: text (no spaces)
(Default = live1)
- Port: 1-65535
(Default = 554)
- Block Size: 1-65535
(Default = 8192)

Multicast Settings:

- Enable: ON, OFF
(Default = OFF)
- Multicast Address:
224.0.0.0 to 239.255.255.255
(Default = 239.128.1.1)
- Multicast TTL: 1-255
(Default = 3)



RTMP

RTMP is used to stream a signal to a dedicated server using the Real-Time Messaging Protocol.

The following settings are available:

- Server: DNS name or IP address
(Default = empty)
- Port: 1-65535
(Default = 1935)
- App (Application Name):
text (no spaces)
(Default = empty)
- Stream Name: text (no spaces)
(Default = empty)
- User Name for authentication at the RTMP server
(Default = empty)
- Password for authentication at the RTMP server
(Default = empty)

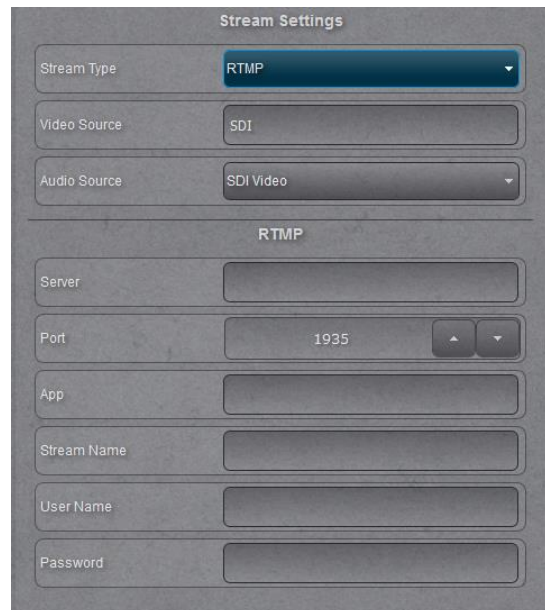

HLS

HLS is used to stream a signal using the HTTP Live Streaming Protocol.

Following settings are available:

- Stream: text (no spaces)
[Default = stream1]

Multiplex settings are specified in section "TS over UDP" above.

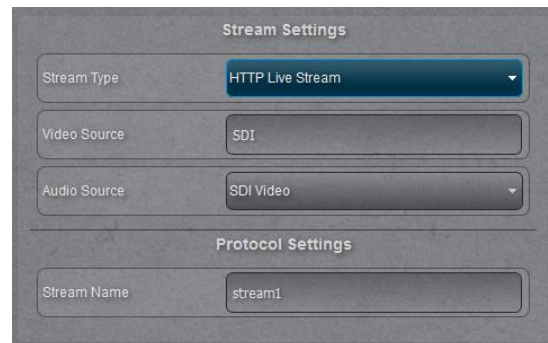

The image shows a screenshot of a configuration interface with two sections: "Stream Settings" and "Protocol Settings".

Stream Settings

- Stream Type: HTTP Live Stream (dropdown menu)
- Video Source: SDI (text input)
- Audio Source: SDI Video (dropdown menu)

Protocol Settings

- Stream Name: stream1 (text input)

Streaming on YouTube

1. Login to YouTube and go to creator studio.

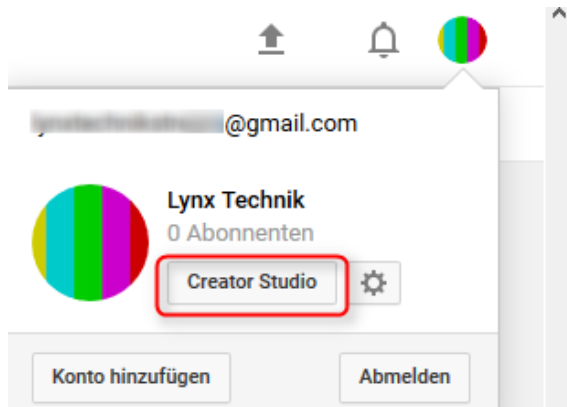

2. Go to Live Streaming > Stream now and scroll down to the ENCODER SETUP.

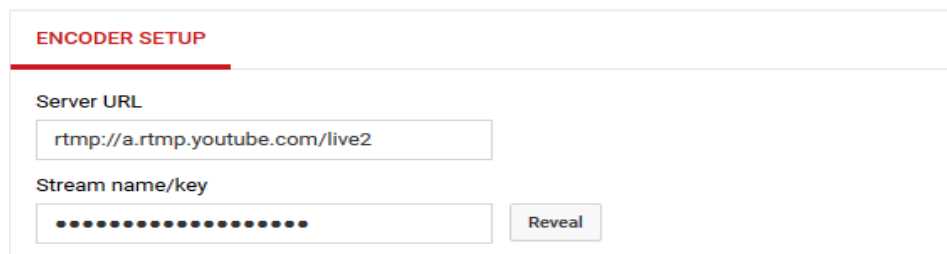

3. Insert the above information in the PEC 1864 as shown in the picture on the right side and the PEC 1864 is ready to stream.

Note: Entry of User Name and Password is not necessary for streaming on YouTube. Other streaming services may require the entry of a username and password, this is normally the username and password used in that streaming service

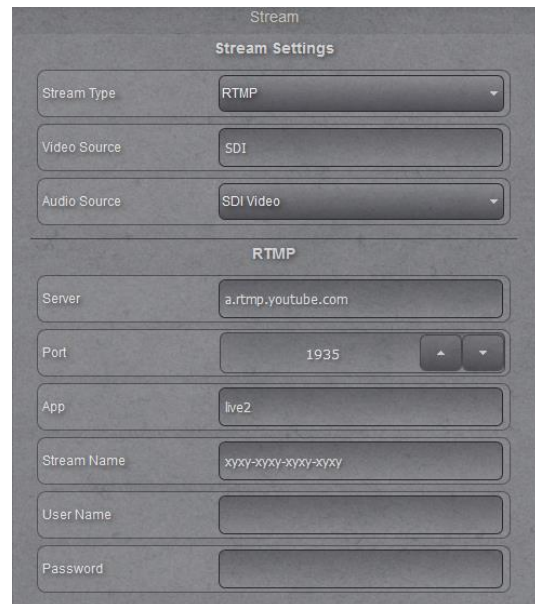

Recorder

The Recorder enables the user to record video streams on a Micro-SD card or a USB memory stick connected to the PEC 1864 module.

A Micro-SD card can be inserted at the slot below the HDMI connector, with the upper side directed to the bottom of the device. A USB memory stick can be connected to the Mini-USB connector of the module, using a USB-OTG adapter.

Recorder Input

- Video Source (HDMI or SDI, display only)
- Audio Source (Off, HDMI, SDI or Analog Audio) [Default = HDMI or SDI, depending on the video source]

Recorder Settings

- Video Encoder: Dual or Single

Note: A 3G signal can be streamed and recorded in single encoder mode only (only one encoder is active, so the encoded signal is the same for streaming and recording). In dual encoder mode the frame rate of a 3G signal will be reduced to 1.5G internally.

- Output Format: MP4; MOV or TS (Default = MP4)
- Output Device: Micro SD or Mini USB (Default = Micro SD)

Note: If Micro SD card is removed and USB device is detected the Output device will be switched to USB. This will survive a power cycle

- Filename Prefix: one word without spaces (Default = empty)

Note: Each recorded stream will get a filename containing a timestamp of the recording start time. An optional prefix is added to that timestamp.

- Start Recording: ON, OFF) (Default = Off)

Note: The recording process can be started and stopped in the Web UI using this on/off switch or via the record button at the left side of the module.

Device Status: Status and free space of the connected SD card or USB stick (display only)

Note: For MOV and MP4 streaming type the record time is limited to 4 hours

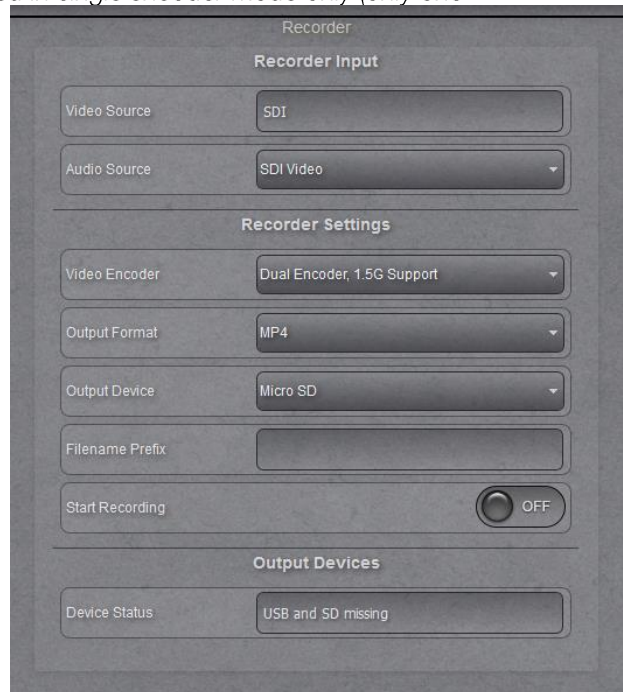

Specifications

SDI Input	1x SDI video on 75 Ohm BNC connector SMPTE, 292M, 424M, 259M with automatic video format and standard detection Return Loss: >15dB from 5MHz to 1.5GHz, >10dB from 1.5GHz to 3GHz Automatic cable EQ (Belden 1694A cable) 340m @ 270Mbit/s, 220m @ 1.5Gbit/s, 160m @ 2.97Gbit/s
HDMI Input	1x 10bit HDMI 1.4a
Audio input	1x 3.5mm stereo jack Unbalanced AC-coupled 10kOhm Line level
Power	3.2VA @ 12VDC nominal (supports 5 - 14VDC input range)
Mechanical	W: 90mm (3.54"), H: 22mm (0.87"), D: 138mm (5.43") - including connectors Weight: 0.25kg (0.55lb)
Ambient	Temperature: 5°C to 40°C (41 F to 104 F) maintaining specification Humidity: 90% maximum, non-condensing
Model #	PEC 1864 - (EAN# 4250479325005)

Technical Support

If you have any questions or require support, please contact your local distributor for further assistance.

Technical support is also available from our website:

<http://support.lynx-technik.com/>

Please do not return products to LYNX without an RMA. Please contact your authorized dealer or reseller for more details.

More detailed product information and product updates may be available on our web site:

www.lynx-technik.com

Contact Information

Please contact your local distributor; this is your local and fastest method for obtaining support and sales information.

LYNX Technik can be contacted directly using the information below.

Address	LYNX Technik AG Brunnenweg 3 D-64331 Weiterstadt Germany
Website	www.lynx-technik.com
E-Mail	info@lynx-technik.com

LYNX Technik manufactures a complete range of high-quality modular products for broadcast and Professional markets. Please contact your local representative or visit our web site for more product information.

LYNXTechnik **AG**[®]

Broadcast Television Equipment