



# yellobrik®

# yellobrik®

## Quick Reference

### Technical Specifications

<b>SDI Input</b>	1 x SDI video on 75 Ohm BNC connector SMPTE 424M, SMPTE 292M, SMPTE 259M
	Multi-standard operation from 270Mbit/s to 3Gbit/s SDTV (525/625) 720p and 1080p (23.98/24/25/29.97/30/50/59.94/60 Hz) 1080psf (23.98/24/25/29.97/30 Hz) 1080i (50/59.94/60 Hz)
	Return Loss: > 15dB to 1.5Gbit/s and > 10dB up to 3Gbit/s
	Automatic cable EQ (Belden 1694A cable) 250m @ 270Mbit/s, 140m @ 1.5Gbit/s, 80m @ 3Gbit/s
<b>Optical I/O (Option)</b>	1 x fiber optic input and / or output Options include: > Single Channel SDI Transmitter or Receiver (singlemode - 10km) > SDI Transceiver (singlemode - 10km) > SDI Transceiver (multimode - 300m) > CWDM versions also available 18 wavelength choices (singlemode - 40km)
	SMPTE 297M - 2006
<b>SDI Output</b>	1 x SDI video. BNC connector, Multi-standard from 270Mbit/s to 3Gbit/s SMPTE 424M, SMPTE 292M, SMPTE 259M
<b>AES I/O (switchable)</b>	4 x AES3id unbalanced inputs or outputs on 75 Ohm BNC connectors AES group selection provided via rotary switch
<b>Power</b>	+12VDC power supply (included)

### PDM 1284 B AES Audio Embedder / De-embedder

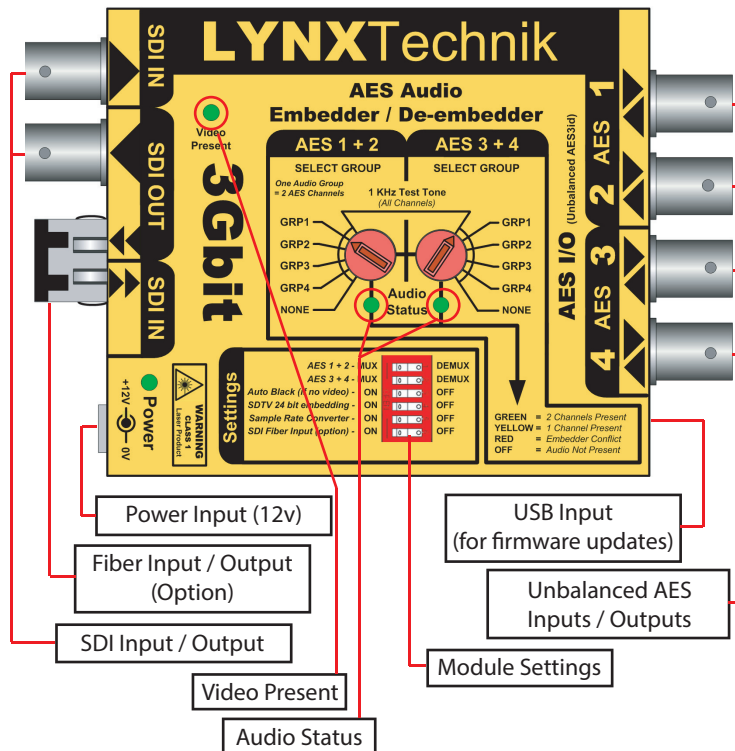

We are constantly adding additional yellobrik modules.  
Please visit our website for the latest product updates.

[www.lynx-technik.com](http://www.lynx-technik.com)

## Connections

All connections are clearly indicated on the module. Connection is self explanatory.

## Operation

The PDM 1284 B functions as a 4 channel embedder and de-embedder for unbalanced AES3id Audio. Simultaneous embedding and de-embedding is also possible. For example, its possible to de-embed and output audio from a selected audio group before overwriting it with new audio.

Rotary switches are provided for AES 1+2 and AES 3+4 audio group selection, and a 1KHz tone can also be selected (all channels)  
(Note. An audio "group" is 2 x AES)

## Settings

A dip switch is provided for module configuration. Settings are indicated on the module and self explanatory.

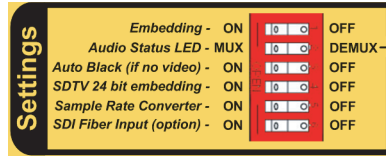

The "Auto Black" function will switch in a black test signal if the input video is lost, allowing for an uninterrupted audio connection. This mode also allows the module to be used to transport audio signals alone if required. Sample rate converters can be turned off to support encoded AES streams such as DolbyE

## Optional Fiber

Optional Fiber I/O can be added at anytime by plugging in the Fiber SFP sub module. This will provide 3Gbit SDI fiber I/O capability (fiber input is selected via the dip switch)

## Power

The module requires a 12V DC power input and a LED is provided to confirm power is connected.

## Cascading Modules

If more than 2 x AES channels are required then its possible to cascade multiple modules. Take the SDI out from one module and connect to the input of another module and select a different audio group. Up to 4 modules can be cascaded to embed the full 8 x AES audio payload into a single SDI stream

## Power Lead Strain Relief

The module has a small hole in the case located above the power connection. To prevent the power lead being accidentally pulled out, use the supplied tie-wrap and secure the lead as shown below.



## Optional Mounting Bracket

The optional RFR 1001 mounting bracket can be used to permanently mount the module on any flat surface or on 19" rack rails.



### Note:

Another module type is shown for illustration purposes only. The principle is the same for the PDM 1284 B